

*Six Mile Creek
Community Development District*

February 10, 2025

AGENDA

February 3, 2025

Board of Supervisors
Six Mile Creek Community Development District

Dear Board Members:

The Meeting of the Board of Supervisors of the Six Mile Creek Community Development District will be held Monday, February 10, 2025 at 2:00 p.m. at the TrailMark Amenity Center, 805 TrailMark Drive, St. Augustine, Florida 32092.

- I. Roll Call
- II. Audience Comments (*regarding agenda items listed below*)
- III. Brightview Report
- IV. Presentation Regarding License Plate Reader
- V. Approval of Consent Agenda
 - A. Engineer Items
 1. Ratification of Requisition No. 202
(2021 Capital Improvement and Refunding Bonds (AA3, Phase 1))
 2. Ratification of Requisition No. 93
(2021 Capital Improvement and Refunding Bonds (AA3, Phase 2))
 3. Ratification of Requisition Nos. 175
(2021 Bond Series (AA2, Phase 3B-East Parcel Phase 2))
 4. Ratification of Requisition
Nos. 98 - 99 (2023 Bond Series
(AA2 Phase 3C))
 5. Ratification of Requisition No. 87A
(2023 Bond Series (AA3 Phase 3-Phase 12))
 6. Ratification of Requisition No. 14 - 18

(2024 Bond Series-Phase 13)

7. Ratification of Change
Order No. 23 Trailmark
Phase 12

- B. Ratification of Agreements / Proposals
 1. Agreement with OnSight Industries, LLC to Furnish & Install Mailboxes (Phase 13)

 2. Agreement with OnSight Industries, LLC to Furnish & Install Signage (Phase 13)

 3. Underground Distribution Facilities Installation Agreement with Florida Power & Light (FPL)

 4. Agreement with Florida Waterways, Inc. for Aquatic Maintenance (Reverie)

 5. Agreement with Florida Waterways, Inc. for Aquatic Maintenance (TrailMark)

 6. Agreement for Security System Operation/Maintenance Services with Envera Systems (Reverie)

- C. Approval of Minutes of the January 8 Meeting

- D. Balance Sheet as of December 31, 2024 and Statement of Revenues and Expenses for the Period Ending December 31, 2024

- E. Assessment Receipt Schedule

- F. Check Register

- VI. Consideration of Proposals for Landscape & Irrigation Maintenance Services RFP (Reverie)

- VII. Review of Reverie Amenity Policies

- VIII. Discussion Items:
 - A. Independent Contractor Agreements

 - B. Policy Enforcement

 - C. Pond Bank Landscape Maintenance (TrailMark)

 - D. Welcome Center Improvements

- IX. Review of Scope of Services for Amenity Management, Field Operations, and Maintenance Services RFP (TrailMark)
- X. Consideration of Proposal from Elite Amenities for Pool Monitor (Summer) (TrailMark)
- XI. Updates Regarding:
 - A. Sidewalk & Irrigation Repair in Phase 9
 - B. Miscellaneous Items throughout the Neighborhood
- XII. Other Business
- XIII. Staff Reports
 - A. Attorney
 - B. Engineer
 - C. Manager
 - D. TrailMark Reports
 - 1. Operations (*RealManage*)- Report
 - 2. Lifestyles (OnPlace) - Report
 - E. Reverie Reports
 - 1. DFH Updates
 - 2. Operations (*First Service*)
 - 3. Lifestyles (*OnPlace*)
 - a. Report
 - b. Water Aerobics
- XIV. Supervisor's Requests
- XV. Audience Comments
- XVI. Next Scheduled Meeting – March 12, 2025 at 2:00 p.m. @ Renaissance World Golf Village Resort
- XVII. Adjournment

Board Oversight

Supervisor Brofford – Pond Maintenance

Supervisor Sutton – Landscape Maintenance

Supervisor Dunn – TrailMark Amenity Center
Supervisor Gellman – Reverie Amenity Center
Supervisor Hartley - Lifestyles

THIRD ORDER OF BUSINESS



Quality Site Assessment

Prepared for: **Six Mile CDD Trailmark**

General Information

- DATE:** Tuesday, Feb 04, 2025
- NEXT QSA DATE:** Monday, May 05, 2025
- CLIENT ATTENDEES:** Alex Boyer
- BRIGHTVIEW ATTENDEES:** Steve McAvoy

Customer Focus Areas

Clubhouse- focal areas(weeds and debris), Complete site, Entrance appearance, Tornado clean up, Hurricane clean up

Quality you can count on.

<h1>7</h1> <p>Seven Standards of Excellence</p>	 <p>1 Site Cleanliness</p>	 <p>2 Weed Free</p>	 <p>3 Green Turf</p>
 <p>4 Crisp Edges</p>	 <p>5 Spectacular Flowers</p>	 <p>6 Uniformly Mulched Beds</p>	 <p>7 Neatly Pruned Trees & Shrubs</p>

Carryover Items



1 Topiary Island- turf weeds have been treated and plumbago plants and ornamental grasses area schedule to be cutback.

2 Plumbago plants will be scheduled to be cut back and fertilized after cold temps have passed



QUALITY SITE ASSESSMENT

Six Mile CDD Trailmark

Maintenance Items



- 1** Athletic field is in good condition and is being mowed as needed during the winter months
- 2** Volleyball court area is clean and weed free
- 3** Trimming is being completed as needed during the winter months
- 4** Plant material beds are being hand pulled and sprayed for weed control on a weekly rotation

Maintenance Items



5 All spartina and Muhly grass cutbacks have been completed to prepare for Pine straw install in March. We are also following up with weed control and pre-emergence applications

6 We are currently working on winter tree elevation throughout community. We are on schedule to wrap up in the beginning of March. We will follow up upon completion

7 Hard and soft surfaces are being edged as needed during the winter months

Recommendations for Property Enhancements



- 1** Large oak limbs are encroaching newly installed palm trees. We recommend removing oak limbs before palms decline.
- 2** Starting to see declining turf at athletic field due to heavily shaded areas. We recommend elevating all three trees around athletic field to open up and allow more sunlight to these areas to promote the health of turf.
- 3** Second example of oak tree needing to be elevated around athletic field to help prevent declining turf
- 4** Second palm tree where Oak limbs need to be cut back away from Palm to avoid damage

QUALITY SITE ASSESSMENT

Six Mile CDD Trailmark

Notes to Owner / Client



- 1** Mistletoe is growing in tree at north east corner of athletic field. We recommend removing to promote the health of tree as this can cause decline. I will get with our team to have this removed
- 2** There are several soft tissue plants that were damaged due to cold around amenity center. We will continue to monitor and see how they bounce back in March

QUALITY SITE ASSESSMENT

Six Mile CDD Trailmark

Completed Items



- 1** Muhly grasses throughout property are scheduled to be cut back in February. We will follow upon completion
- 2** We are starting to see several ant mounds popping up throughout the community. We will have our teams treat as needed
- 3** Common area beds are being treated for weed control on a weekly rotation
- 4** There is a heavy stand of leaves located at Kayak parking area. We will have our team remove during next visit

Completed Items



- 5** Low hanging moss in trees have been scheduled to be removed.

Trees elevated along Trailmark Drive



FOURTH ORDER OF BUSINESS

Would you support the installation of a License Plate Reader (LPR) at the front entrance of the community?

381 responses

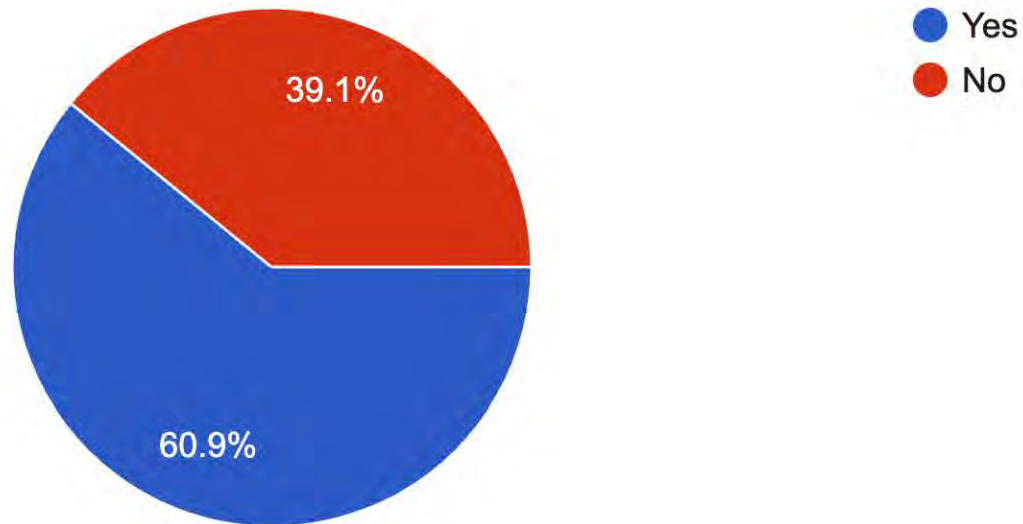

FIFTH ORDER OF BUSINESS

A.

Six Mile Creek Community Development District

February 10, 2025

1. Ratification of Requisition No. 202
(2021 Capital Improvement and Refunding Bonds (AA3, Phase 1))
2. Ratification of Requisition No. 93
(2021 Capital Improvement and Refunding Bonds (AA3, Phase 2))
3. Ratification of Requisition Nos. 175
(2021 Bond Series (AA2, Phase 3B-East Parcel Phase 2))
4. Ratification of Requisition Nos. 98 - 99
(2023 Bond Series (AA2 Phase 3C))
5. Ratification of Requisition No. 87A
(2023 Bond Series (AA3 Phase 3-Phase 12))
6. Ratification of Requisition No. 14 - 18
(2024 Bond Series-Phase 13)
7. Ratification of Change Order No. 23
Trailmark Phase 12

**Scott A. Wild
District Engineer
England-Thims & Miller, Inc.**

SIX MILE CREEK COMMUNITY DEVELOPMENT DISTRICT

REQUISITION SUMMARY

2021 Capital Improvement and Refunding Revenue Bonds (Assessment Area 3, Phase 2)

Series 2023 (2023 Project Area) Capital Improvement Revenue Bonds

Series 2024 (2024 Project Area)

REQUISITIONS February 10, 2025

<u>Date of Requisition</u>		<u>Payee</u>	<u>Reference</u>		<u>INVOICE AMOUNT</u>
2021 Capital Improvement and Refunding Revenue Bonds (Assessment Area 3, Phase 1)					
February	202	Adkins Electric, Inc.	Rain Bird pump installation - Invoice 1099		\$ 1,378.00
2021 Capital Improvement and Refunding Revenue Bonds (AA 2, Phase 3A) BOND SERIES					\$ 1,378.00
<u>Date of Requisition</u>		<u>Payee</u>	<u>Reference</u>		<u>INVOICE AMOUNT</u>
2021 Capital Improvement and Refunding Revenue Bonds (Assessment Area 3, Phase 2) (Phase 10) BOND SERIES					
February	93	Kutak Rock LLP	Professional Services related to Project Construction-Invoices 3512050 18323-2 (Oct-Nov 2024)		\$ 866.00
2021 Capital Improvement and Refunding Revenue Bonds (AA 3, Phase 2) (Phase 10) BOND SERIES					\$ 866.00
<u>Date of Requisition</u>		<u>Payee</u>	<u>Reference</u>		<u>INVOICE AMOUNT</u>
2021 Capital Improvement and Refunding Revenue Bonds (A/C 226000005) (Assessment Area 2, Phase 3B) (East Parcel Phase 2) BOND SERIES					
February	175	ETM	Master Site Planning (WA#51) Invoice 217490 (December 2024)		\$ 726.71
2021 Capital Improvement and Refunding Revenue Bonds (A/C 226000005) (Assessment Area 2, Phase 3B) (East Parcel Phase 2) BOND SERIES					\$ 726.71
<u>Date of Requisition</u>		<u>Payee</u>	<u>Reference</u>		<u>INVOICE AMOUNT</u>
2023 Capital Improvement Revenue Bonds (Series 2023) 2023 Project Area BOND SERIES					
February	98	SES Environmental Resource	Trailmark haul road restoration - Invoice 40770		\$ 26,200.00
February	99	ETM	Trailmark East Parcel - Phase 3 CEI (WA#73) Invoice 217515 (December 2024)		\$ 2,281.90
2023 Capital Improvement Revenue Bonds (Series 2023) 2023 Project Area BOND SERIES					\$ 28,481.90
<u>Date of Requisition</u>		<u>Payee</u>	<u>Reference</u>		<u>INVOICE AMOUNT</u>
2023 Capital Improvement Revenue Bonds (Series 2023) 2023 Project Area BOND SERIES					
February	87A	ETM	Trailmark Phase 12 - CEI (WA#70) Invoice 217515 (December 2024)	\$ 2,281.90	\$ 9,141.90
			Trailmark Drive at Pacetti Road-Traffic Signal Design Services (WA#79) Invoice 217853 (December 2024)	\$ 6,860.00	
2023 Capital Improvement Revenue Bonds (Series 2023) 2023 Project Area BOND SERIES					\$ 9,141.90
<u>Date of Requisition</u>		<u>Payee</u>	<u>Reference</u>		<u>INVOICE AMOUNT</u>
2024 Capital Improvement Revenue Bonds (Series 2024) 2024 Project Area BOND SERIES					
February	14	Six Mile Creek CDD	Reimbursement for Reverie Amenity Construction matters		\$ 25,760.00
February	15	England-Thims & Miller, Inc.	Phase 13 CEI - Invoice 217039 (November 2024)		\$ 9,827.48
February	16	England-Thims & Miller, Inc.	Public Facilities Report (WA#83) Invoice 217551		\$ 109.50
February	17	Onsight	Trailmark Street signage - Invoice 427281		\$ 4,183.50
February	18	Ferguson Enterprises, LLC	Direct Owner Purchase Invoices - Trailmark Phase 13		\$ 27,016.00
2024 Capital Improvement Revenue Bonds (Series 2024) 2024 Project Area BOND SERIES					\$ 66,896.48
TOTAL REQUISITIONS TO BE APPROVED February 10, 2025					\$ 107,490.99

CHANGE ORDER

No. 23

DATE OF ISSUANCE: January 8, 2025

EFFECTIVE DATE: January 8, 2025

OWNER: Six Mile Creek Community Development District

CONTRACTOR: Jax Utilities Management, Inc.

Contract: Trailmark Phase 12

Project: Trailmark Phase 12

OWNER's Contract No. N.A.

ENGINEER's Contract No. 20-277

ENGINEER: England – Thims and Miller, Inc.

You are directed to make the following changes in the Contract Documents:

Description: Trailmark Phase 12 Phase 3C Tree Removal

Reason for Change: - Trailmark Phase Phase 3C - Remove 3 dead trees

Attachments: (List documents supporting change) Jax Utilities Management, Inc. proposed change order dated January 6, 2025

By execution of this change order document, the Contractor acknowledges that all issues related to Contract Time and Compensation for the work associated with these changes are resolved.

CHANGE IN CONTRACT PRICE:
Original Contract Price <u>\$ 11,492,616.00</u>
Net Increase /Decrease from previous Change Orders No. <u>0</u> to No. <u>22</u> <u>\$ (303,760.38)</u>
Contract Price prior to this Change Order: <u>\$ 11,188,855.62</u>
Net Increase/ Decrease of this Change Order: <u>\$ 1,800.00</u>
Contract Price with all approved Change Orders: <u>\$ 11,190,655.62</u>

CHANGE IN CONTRACT TIMES:
Original Contract Times: Substantial Completion: <u>480</u> Ready for final payment: <u>540</u> (days)
Net change from previous Change Orders No. <u>-0-</u> to No. <u>22</u> Substantial Completion: <u>91</u> Ready for final payment: <u>91</u> (days)
Contract Times prior to this Change Order: Substantial Completion: <u>571</u> Ready for final payment: <u>631</u> (days)
Net Increase this Change Order: Substantial Completion: <u>0</u> Ready for final payment: <u>0</u> (days)
Contract Times with all approved Change Orders: Substantial Completion: <u>571</u> Ready for final payment: <u>631</u> (days)

RECOMMENDED:

By: [Signature]
ENGINEER (Authorized Signature)

APPROVED:

By: [Signature]
OWNER (Authorized Signature)

ACCEPTED:

By: [Signature]
CONTRACTOR (Authorized Signature)

Date: January 8, 2025

Date: 1/8/2025

Date: January 8, 2025

EJCDC 1910-8-B (1996 Edition)

Prepared by the Engineers Joint Contract Documents Committee and endorsed by The Associated General Contractors of America and the Construction Specifications Institute.

CHANGE ORDER REQUEST



Serving NE Florida Since 1974

Project: Trailmark 12
 Owner: Six Mile Creek CDD
 Engineer: England-Thims & Miller

Change Order No: 23
 Date: 1/6/2025
 Contract for: SITE WORK

Charlie Freshwater - President | Rick Johns - Vice President | Steven Jordan - CFO

SCOPE

The contract is changed as follows:

Item	Previous Change Orders	Qty	Unit	Unit Price	Total Price
01	Various changes. See SOV.	1	LS	\$722,431.60	\$722,431.60
02	4A Concrete & Asphalt Repairs	1	LS	\$462,598.75	\$462,598.75
03	ADS Credit	1	LS	-\$42,800.00	-\$42,800.00
04	5A & 7 Concrete & Asphalt Repairs	1	LS	\$301,081.75	\$301,081.75
05	Material Deduct	1	LS	-\$1,410,064.73	-\$1,410,064.73
06	Wetland Outfall	1	LS	\$411,000.00	\$411,000.00
07	TM-11 Repairs Paid by Owner Damage Allstate Elec.	1	LS	-\$16,671.25	-\$16,671.25
08	Rec Pond Storm and Import Credit Roadway and Lots	1	LS	-\$1,194,560.00	-\$1,194,560.00
09	Pothole Repairs	1	LS	\$1,500.00	\$1,500.00
10	Mail Kiosk	1	LS	\$88,970.00	\$88,970.00
11	FPL Easement Road	1	LS	\$96,750.00	\$96,750.00
12	Grading Amenity Center	1	LS	\$7,105.00	\$7,105.00
13	Mod EX-305A Knockout	1	LS	\$4,300.00	\$4,300.00
14	Rain Days (2)	1	LS	\$0.00	\$0.00
15	FPL Easment Certified As-builts	1	LS	\$3,000.00	\$3,000.00
16	FPL Electric	1	LS	-\$156,050.50	-\$156,050.50
17	Cronin Utilities	1	LS	\$52,906.00	\$52,906.00
18	Re-Grade Wetland Outfall	1	LS	\$37,090.00	\$37,090.00
19	Teco Damage	1	LS	\$2,800.00	\$2,800.00
20	TM-11 Curb & Pond 32 Repair	1	LS	\$12,908.00	\$12,908.00
21	8' Path at Rec Pond	1	LS	\$115,050.00	\$115,050.00
22	Cronin Drive	1	LS	\$196,895.00	\$196,895.00

SUMMARY

The original Contract Sum was:

\$ 11,492,616.00

The net change by previously authorized Change Orders:	-\$303,760.38
The Contract Sum prior to this Change Order was:	\$ 11,188,855.62
The Contract Sum will be increased (decreased) by this Change Order in the amount of:	\$1,800.00
The new Contract Sum including this Change Order will be:	\$ 11,190,655.62

TIME

The original commencement date was: 2/21/2023

Original days to Substantial Completion was:	480	days	Date:	6/15/2024
Original days to Final Completion was:	540	days	Date:	8/14/2024
Days added prior to this change order was:	91	days		

Days will be increased (decreased) by: 0 days

Current Substantial Completion:	571	days	Date:	9/14/2024	New days to Substantial Completion:	571	days	Date:	9/14/2024
Current Final Completion:	631	days	Date:	11/13/2024	New days to Final Completion:	631	days	Date:	11/13/2024



Serving NE Florida Since 1974

Charlie Freshwater - President | Rick Johns - Vice President | Steven Jordan - CFO

Date 1/6/2025

Change Order Proposal & Scope of Work

Project: Trailmark 12
 Owner: Six Mile Creek CDD
 Engineer: England-Thims & Miller
 Geotech: ECS of Florida, LLC
 Surveyor: Clary & Associates, Inc.

Item	Description: Tree Removal 12 C	Quantity	Units	Unit Price	Total Price
1	Tree Removal TM 12-C	1		\$ 1,800.00	\$ 1,800.00
2					\$ -
3					\$ -
4					\$ -
5					\$ -
6					\$ -
7					\$ -
8					\$ -
9					\$ -
10					\$ -
11					\$ -
12					\$ -
14					\$ -
15					\$ -
16					\$ -
17					\$ -
18					\$ -
20	Notes				\$ -
	3 large trees: one by retaining wall, and two along woodline in TM12-C				\$ -
				Total	\$ 1,800.00

B.

1.

**AGREEMENT BETWEEN SIX MILE CREEK COMMUNITY DEVELOPMENT
DISTRICT AND ONSIGHT INDUSTRIES, LLC
TO FURNISH & INSTALL MAILBOXES**

This Agreement is made and entered into by and between the following parties, and with an effective date of January 9, 2025:

SIX MILE CREEK COMMUNITY DEVELOPMENT DISTRICT, a local unit of special-purpose government established pursuant to Chapter 190, Florida Statutes, being situated in St. Johns County, Florida (“District”), and

ONSIGHT INDUSTRIES, LLC, a Florida limited liability company with an address of 900 Central Park Drive, Sanford, Florida 32771 (hereinafter “Contractor” and, with the District, the “Parties”).

RECITALS

WHEREAS, the District was established for the purpose of planning, financing, constructing, operating and/or maintaining certain infrastructure, including among other things, recreational amenities; and

WHEREAS, the District has a need to retain an independent contractor to furnish and provide the labor and materials necessary to install certain public improvements within the District as more particularly described herein; and

WHEREAS, Contractor represents that it is licensed and qualified to furnish and install mailboxes and to provide the District with those materials and services identified in Contractor’s Proposal dated November 15, 2024, the related drawings, attached hereto as **Composite Exhibit A** and incorporated by reference herein (“Work”); and

WHEREAS, Contractor agrees to install the mailboxes and perform the Work described in **Composite Exhibit A**;

WHEREAS, the District desires to enter into this Agreement to have Contractor furnish the mailboxes and provide the materials and perform the services as more particularly described herein.

NOW, THEREFORE, in consideration of the recitals, agreements, and mutual covenants contained herein, and other good and valuable consideration, the receipt and sufficiency of which are hereby acknowledged by the Parties, the Parties agree as follows:

SECTION 1. RECITALS. The recitals so stated are true and correct and by this reference are incorporated into and form a material part of this Agreement.

SECTION 2. DUTIES AND COMPENSATION.

- A.** District agrees to use Contractor to provide the materials and services in accordance with the terms of this Agreement. The duties, obligations, and responsibilities of Contractor are to furnish mailboxes and provide the material, tools, skill, and labor necessary to install the mailboxes as delineated in **Composite Exhibit A** and herein. The installation shall be at the locations referenced in **Composite Exhibit A**.
- B.** The District shall pay Contractor a total amount of **\$33,366.00** (Thirty-Three Thousand Three Hundred Sixty-Six Dollars) for the Work as identified in **Composite Exhibit A**. Contractor shall invoice the District following the completion, and District's acceptance, of the Work. Compensation includes, but is not limited to, all permits, parts, materials and labor necessary to complete the Work as described herein. The District shall provide payment no later than forty five (45) days following the District's receipt of the invoice or as otherwise provided for under the Local Government Prompt Payment Act, Sections 218.70 et seq., Florida Statutes.
- C.** Contractor agrees to render a final invoice to the District, in writing, which shall be delivered or mailed to the District no later than the 5th day of the next succeeding month. The District, upon receipt of such timely invoice, shall pay the Contractor within thirty (30) days of receipt of such an invoice.
- D.** Contractor shall be solely responsible for the means, manner and methods by which its duties, obligations and responsibilities are met to the satisfaction of the District with the exception of those specifically provided for herein. All Work shall be performed in a neat and professional manner reasonably acceptable to the District and shall be in accordance with industry standards and best practices and this Agreement.
- E.** Should any work and/or services be required which are not specified in this Agreement or any addenda, but which are nevertheless necessary for the proper provision of Work to the District, such work or services shall be fully performed by the Contractor as if described and delineated in this Agreement without additional compensation provided therefore.
- F.** The Contractor agrees that the District shall not be liable for the payment of any additional services unless the District, through an authorized representative of the District, authorizes the Contractor, in writing, to perform such additional services.
- G.** Contractor shall use all due care to protect the property of the District, its residents and landowners from damage. Contractor agrees to repair any damage resulting from Contractor's activities and work within twenty-four (24) hours.

SECTION 3. TERMINATION. The District agrees that the Contractor may terminate this Agreement for cause by providing thirty (30) days written notice of termination to the District; provided, however, that the District shall be provided a reasonable opportunity to cure any failure under this Agreement. The Contractor agrees that the District may terminate this Agreement

immediately for cause by providing written notice of termination to the Contractor. The District shall provide fifteen (15) days written notice of termination without cause. Upon any termination of this Agreement, and as the Contractor's sole and exclusive remedy for any termination hereunder, the Contractor shall be entitled to payment for all Work rendered up until the effective termination of this Agreement, subject to whatever claims or off sets the District may have against the Contractor.

SECTION 4. WARRANTY. The Contractor warrants to the District that all materials furnished under this Agreement shall be new, and that all services and materials shall be of good quality, free from faults and defects. In addition to all manufacturer warranties for materials purchased for purposes of this Agreement, all Work, including but not limited to services and materials, provided by the Contractor pursuant to this Agreement shall be warranted for five years from the date of the final acceptance by the District of the Work.

SECTION 5. INSURANCE.

A. The Contractor shall maintain throughout the term of this Agreement the following insurance:

- (1)** Worker's Compensation Insurance in accordance with the laws of the State of Florida.
- (2)** Commercial General Liability Insurance covering the Contractor's legal liability for bodily injuries, with limits of not less than one million dollars (\$1,000,000) combined single limit bodily injury and property damage liability, and covering at least the following hazards:
 - (i)** Independent Contractors Coverage for bodily injury and property damage in connection with any subcontractors' operation.
- (3)** Employer's Liability Coverage with limits of at least one million dollars (\$1,000,000) per accident or disease.
- (4)** Automobile Liability Insurance for bodily injuries in limits of not less than one million dollars (\$1,000,000) combined single limit bodily injury and for property damage, providing coverage for any accident arising out of or resulting from the operation, maintenance, or use by the Contractor of any owned, non-owned, or hired automobiles, trailers, or other equipment required to be licensed.

B. The District, its staff, consultants and supervisors shall be named as additional insured. The Contractor shall furnish the District with the Certificate of Insurance evidencing compliance with this requirement. No certificate shall be acceptable to the District unless it provides that any change or termination within the policy periods of the insurance coverage, as certified, shall not be effective within thirty

(30) days of prior written notice to the District. Insurance coverage shall be from a reputable insurance carrier, licensed to conduct business in the State of Florida.

- C. If the Contractor fails to have secured and maintained the required insurance, the District has the right but not the obligation to secure such required insurance in which event the Contractor shall pay the cost for that required insurance and shall furnish, upon demand, all information that may be required in connection with the District's obtaining the required insurance.

SECTION 6. E-VERIFY REQUIREMENTS.

- A. The Contractor shall comply with and perform all applicable provisions of Section 448.095, *Florida Statutes*. Accordingly, beginning January 1, 2021, to the extent required by Florida Statute, Contractor shall register with and use the United States Department of Homeland Security's E-Verify system to verify the work authorization status of all newly hired employees. The District may terminate this Agreement immediately for cause if there is a good faith belief that the Contractor has knowingly violated Section 448.091, Florida Statutes.
- B. If the Contractor anticipates entering into agreements with a subcontractor for the Work, Contractor will not enter into the subcontractor agreement without first receiving an affidavit from the subcontractor regarding compliance with Section 448.095, *Florida Statutes*, and stating that the subcontractor does not employ, contract with, or subcontract with an unauthorized alien. Contractor shall maintain a copy of such affidavit for the duration of the agreement and provide a copy to the District upon request.
- C. In the event that the District has a good faith belief that a subcontractor has knowingly violated Section 448.095, *Florida Statutes*, but the Contractor has otherwise complied with its obligations hereunder, the District shall promptly notify the Contractor. The Contractor agrees to immediately terminate the agreement with the subcontractor upon notice from the District. Further, absent such notification from the District, the Contractor or any subcontractor who has a good faith belief that a person or entity with which it is contracting has knowingly violated s. 448.09(1), Florida Statutes, shall promptly terminate its agreement with such person or entity.
- D. By entering into this Agreement, the Contractor represents that no public employer has terminated a contract with the Contractor under Section 448.095(2)(c), *Florida Statutes*, within the year immediately preceding the date of this Agreement.

SECTION 7. INDEMNIFICATION.

- A. Obligations under this section shall include the payment of all settlements, judgments, damages, liquidated damages, penalties, forfeitures, back pay awards, court costs, arbitration and/or mediation costs, litigation expenses, attorney fees, paralegal expert witness fees (incurred in court, out of court, on appeal, or in bankruptcy proceedings),

any interest, expenses, damages, penalties, fines, or judgments against the District.

- B.** Contractor agrees to defend, indemnify, and hold harmless the District and its officers, agents, employees, successors, assigns, members, affiliates, or representatives from any and all liability, claims, actions, suits, liens, demands, costs, interest, expenses, damages, penalties, fines, judgments against the District, or loss or damage, whether monetary or otherwise, arising out of, wholly or in part by, or in connection with the Services to be performed by Contractor, its subcontractors, its employees and agents in connection with this Agreement, including litigation, mediation, arbitration, appellate, or settlement proceedings with respect thereto. Additionally, nothing in this Agreement requires Contractor to indemnify the District for the District's percentage of fault if the District is adjudged to be more than 50% at fault for any claims against the District and Contractor as jointly liable parties; however, Contractor shall indemnify the District for any and all percentage of fault attributable to Contractor for claims against the District, regardless whether the District is adjudged to be more or less than 50% at fault.

SECTION 8. COMPLIANCE WITH GOVERNMENTAL REGULATION. The Contractor shall keep, observe, and perform all requirements of applicable local, state, and federal laws, rules, regulations, or ordinances. If the Contractor fails to notify the District in writing within five (5) days of the receipt of any notice, order, required to comply notice, or a report of a violation or an alleged violation, made by any local, state, or federal governmental body or agency or subdivision thereof with respect to the services being rendered under this Agreement or any action of the Contractor or any of its agents, servants, employees, or materialmen, or with respect to terms, wages, hours, conditions of employment, safety appliances, or any other requirements applicable to provision of services, or fails to comply with any requirement of such agency within five (5) days after receipt of any such notice, order, request to comply notice, or report of a violation or an alleged violation, the District may terminate this Agreement, such termination to be effective immediately upon the giving of notice of termination.

SECTION 9. LIENS AND CLAIMS. The Contractor shall promptly and properly pay for all labor employed, materials purchased, and equipment hired by it to perform under this Agreement. The Contractor shall keep the District's property free from any materialmen's or mechanic's liens and claims or notices in respect to such liens and claims, which arise by reason of the Contractor's performance under this Agreement, and the Contractor shall immediately discharge any such claim or lien. In the event that the Contractor does not pay or satisfy such claim or lien within three (3) business days after the filing of notice thereof, the District, in addition to any and all other remedies available under this Agreement, may terminate this Agreement to be effective immediately upon the giving of notice of termination.

SECTION 10. LIMITATIONS ON GOVERNMENTAL LIABILITY. Nothing in this Agreement shall be deemed as a waiver of the District's sovereign immunity or the District's limits of liability as set forth in Section 768.28, Florida Statutes or other law, and nothing in this Agreement shall inure to the benefit of any third party for the purpose of allowing any claim which would otherwise be barred under such limitations of liability or by operation of law.

SECTION 11. NO THIRD PARTY BENEFICIARIES. This Agreement is solely for the benefit of the formal Parties herein and no right or cause of action shall accrue upon or by reason hereof, to or for the benefit of any third party not a formal party hereto. Nothing in this Agreement expressed or implied is intended or shall be construed to confer upon any person or corporation other than the Parties hereto any right, remedy or claim under or by reason of this Agreement or any provisions or conditions hereof; and all of the provisions, representations, covenants and conditions herein contained shall inure to the sole benefit of and shall be binding upon the Parties hereto and their respective representatives, successors and assigns.

SECTION 12. INDEPENDENT CONTRACTOR. In all matters relating to this Agreement, the Contractor shall be acting as an independent contractor. Neither the Contractor nor employees of the Contractor, if there are any, are employees of the District under the meaning or application of any Federal or State Unemployment or Insurance Laws or Old Age Laws or otherwise. The Contractor agrees to assume all liabilities or obligations imposed by any one or more of such laws with respect to employees of the Contractor, if there are any, in the performance of this Agreement. The Contractor shall not have any authority to assume or create any obligation, express or implied, on behalf of the District and the Contractor shall have no authority to represent the District as an agent, employee, or in any other capacity, unless otherwise set forth in this Agreement.

SECTION 13. AGREEMENT. This instrument shall constitute the final and complete expression of the agreement between the District and Contractor relating to the subject matter of this Agreement. None of the provisions of Exhibit A shall apply to this Agreement and Exhibit A shall not be incorporated herein, except that Exhibit A is applicable to the extent that it states the Work's scope of services for the labor and materials to be provided under this Agreement.

SECTION 14. AMENDMENTS. Amendments to and waivers of the provisions contained in this Agreement may be made only by an instrument in writing which is executed by both the District and Contractor.

SECTION 15. AUTHORIZATION. The execution of this Agreement has been duly authorized by the appropriate body or official of the District and Contractor, both the District and Contractor have complied with all the requirements of law, and both the District and Contractor have full power and authority to comply with the terms and provisions of this Agreement.

SECTION 16. NOTICES. All notices, requests, consents and other communications under this Agreement ("Notices") shall be in writing and shall be hand delivered, mailed by First Class Mail, postage prepaid, or sent overnight delivery service, to the Parties, as follows:

- A. If to District:** Six Mile Creek Community Development District
475 West Town Place, Suite 114
St. Augustine, Florida 32092
Attn: District Manager

With a copy to: Kutak Rock LLP
107 W. College Ave.
Tallahassee, Florida 32301
Attn: District Counsel

B. If to the Contractor: Onsight, Inc.
900 Central Park Drive
Sanford, Florida 32771
Attn: Dan Kristoff

Except as otherwise provided in this Agreement, any Notice shall be deemed received only upon actual delivery at the address set forth above. Notices delivered after 5:00 p.m. (at the place of delivery) or on a non-business day, shall be deemed received on the next business day. If any time for giving Notice contained in this Agreement would otherwise expire on a non-business day, the Notice period shall be extended to the next succeeding business day. Saturdays, Sundays, and legal holidays recognized by the United States government shall not be regarded as business days. Counsel for District and counsel for Contractor may deliver Notice on behalf of the District and Contractor. Any party or other person to whom Notices are to be sent or copied may notify the other Parties and addressees of any change in name or address to which Notices shall be sent by providing the same on five (5) days written notice to the Parties and addressees set forth in this Agreement.

SECTION 17. ENFORCEMENT OF AGREEMENT. In the event that either the District or Contractor is required to enforce this Agreement by court proceedings or otherwise, then the prevailing party shall be entitled to recover all fees and costs incurred, including reasonable attorneys' fees and costs for trial, alternative dispute resolution, or appellate proceedings.

SECTION 18. CONTROLLING LAW AND VENUE. This Agreement and the provisions contained in this Agreement shall be construed, interpreted, and controlled according to the laws of the State of Florida. All actions and disputes shall be brought in the proper court and venue, which shall be St. Johns County, Florida.

SECTION 19. PUBLIC RECORDS. Contractor understands and agrees that all documents of any kind provided to the District in connection with this Agreement may be public records, and, accordingly, Contractor agrees to comply with all applicable provisions of Florida law in handling such records, including but not limited to Section 119.0701, *Florida Statutes*. Contractor acknowledges that the designated public records custodian for the District is **Jim Oliver**, District Manager ("Public Records Custodian"). Among other requirements and to the extent applicable by law, the Contractor shall 1) keep and maintain public records required by the District to perform the service; 2) upon request by the Public Records Custodian, provide the District with the requested public records or allow the records to be inspected or copied within a reasonable time period at a cost that does not exceed the cost provided in Chapter 119, *Florida Statutes*; 3) ensure that public records which are exempt or confidential, and exempt from public records disclosure requirements, are not disclosed except as authorized by law for the duration of the contract term and following the contract term if the Contractor does not transfer the records to the Public Records

Custodian of the District; and 4) upon completion of the contract, transfer to the District, at no cost, all public records in Contractor's possession or, alternatively, keep, maintain and meet all applicable requirements for retaining public records pursuant to Florida laws. When such public records are transferred by the Contractor, the Contractor shall destroy any duplicate public records that are exempt or confidential and exempt from public records disclosure requirements. All records stored electronically must be provided to the District in a format that is compatible with Microsoft Word or Adobe PDF formats.

IF THE CONTRACTOR HAS QUESTIONS REGARDING THE APPLICATION OF CHAPTER 119, *FLORIDA STATUTES*, TO THE CONTRACTOR'S DUTY TO PROVIDE PUBLIC RECORDS RELATING TO THIS CONTRACT, CONTACT THE CUSTODIAN OF PUBLIC RECORDS AT 475 WEST TOWN PLACE, SUITE 114, ST. AUGUSTINE, FLORIDA 32092, PHONE: (904) 940-5850, E-MAIL JOLIVER@GMSNF.COM

SECTION 20. SEVERABILITY. The invalidity or unenforceability of any one or more provisions of this Agreement shall not affect the validity or enforceability of the remaining portions of this Agreement, or any part of this Agreement not held to be invalid or unenforceable.

SECTION 21. HEADINGS FOR CONVENIENCE ONLY. The descriptive headings in this Agreement are for convenience only and shall neither control nor affect the meaning or construction of any of the provisions of this Agreement.

SECTION 22. COUNTERPARTS. This Agreement may be executed in any number of counterparts, each of which when executed and delivered shall be an original; however, all such counterparts together shall constitute, but one and the same instrument.

SECTION 23. NEGOTIATION AT ARM'S LENGTH. This Agreement has been negotiated fully between the Parties as an arm's length transaction. The Parties participated fully in the preparation of this Agreement and received the advice of counsel. In the case of a dispute concerning the interpretation of any provision of this Agreement, all Parties are deemed to have drafted, chosen and selected the language, and the doubtful language will not be interpreted or construed against any party.

SECTION 24. ASSIGNMENT. Neither party may assign this Agreement or any monies to become due hereunder without the prior written approval of the other party.

SECTION 25. AGREEMENT CONTROLS. To the extent that any of the provisions in the attached Exhibit A and this Agreement conflict, the terms of this Agreement controls.

SECTION 26. COMPLIANCE WITH SECTION 20.055, *FLORIDA STATUTES*. The Contractor agrees to comply with Section 20.055(5), *Florida Statutes*, to cooperate with the inspector general in any investigation, audit, inspection, review, or hearing pursuant to such section

and to incorporate in all subcontracts the obligation to comply with Section 20.055(5), *Florida Statutes*.

SECTION 27. SCRUTINIZED COMPANIES STATEMENT. Contractor certifies it: (i) is not in violation of Section 287.135, *Florida Statutes*; (ii) is not on the Scrutinized Companies with Activities in Sudan List; (iii) is not on the Scrutinized Companies with Activities in the Iran Petroleum Energy Sector List; (iv) does not have business operations in Cuba or Syria; (v) is not on the Scrutinized Companies that Boycott Israel List; and (vi) is not participating in a boycott of Israel. If the Contractor is found to have submitted a false statement with regards to the prior sentence, has been placed on the Scrutinized Companies with Activities in Sudan List, the Scrutinized Companies with Activities in the Iran Petroleum Energy Sector List, or the Scrutinized Companies that Boycott Israel List, has engaged in business operations in Cuba or Syria, and/or has engaged in a boycott of Israel, the District may immediately terminate the Contract.

[CONTINUED ON FOLLOWING PAGE]

IN WITNESS WHEREOF, the Parties hereto have signed this Agreement to be effective on the day and year first written above.

ATTEST:

Signed by:
Daniel Laughlin

9A989FE97A6A46D...
Secretary/Assistant Secretary

**SIX MILE CREEK COMMUNITY
DEVELOPMENT DISTRICT**
Signed by:
Michelle Sutton

EEAF51DA3F10477...
Chairperson, Board of Supervisors

WITNESS:

By: Caroline Kennerly

ONSIGHT INDUSTRIES, LLC
Signed by:
Brad Osleger

CE3DCA96A1674C...
By: Brad Osleger
Its: President

Composite Exhibit A: Contractor's Proposal and Drawings

Composite Exhibit A
Contractor's Proposal and Drawings



PROPOSAL
W000382331

OnSight Industries, LLC
900 Central Park Dr
Sanford FL 32771

Written By: LEE KENNERLY

Date: 11/15/2024

Proposal: W000382331

Bill To:

SIX MILE CREEK CDD
475 WEST TOWN PLACE
SUITE 114
ST AUGUSTINE FL 32092

Location:

TRAILMARK
475 WEST TOWN PLACE SUITE 114
SAINT AUGUSTINE FL 32092

Project Name: CBU MAILBOXES (197) PHASE 13

Line	Item	U/M	Unit Price	Qty	Net Amount
1	ITEM-MAILBOX-16 DOOR STANDARD D.BRONZE MAILBOX FLORENCE CBU PEDESTAL 16 DOOR STANDARD DARK BRONZE SEQ NUMBERING PLACARDS	EA	2,643.00	12.000	31,716.00
3	LABOR/INSTALL JACKSONVILLE LOCAL 45+ LABOR / INSTALLATION INSTALL JACKSONVILLE LOCAL 35	EA	1,650.00	1.000	1,650.00
4	ITEM-MAILBOX-M003879 MAILBOX USPS COORDINATION	EA	0.00	1.000	0.00



PROPOSAL

W000382331

Line	Item	U/M	Unit Price	Qty	Net Amount
Pre-Tax Total:					33,366.00
Sales Tax:					0.00
Total:					33,366.00

Terms and Conditions:

- All agreements are contingent upon delays and material cost increases beyond our control. Manufacturing cost increases incurred after quotation and prior to a work order being submitted to production will be passed through to the customer. In this scenario, the project will be required for customer approval. - Pricing in this proposal is subject to acceptance within 14 days and is void thereafter. - Depending upon the agreed credit terms, a deposit may be required before work is to commence. - If a deposit is to be paid by credit card, you authorize OnSight Industries, LLC to charge 50% of the total project cost upfront and the balance of the project upon completion. - Any labor and installation pricing is approximate and subject to change based upon actual time incurred. - Delivery/installation postponement will result in the client being progress billed for completed product. At this time, title for the product will transfer to the client. Client agrees to pay progress bill invoice upon receipt. Product will be warehoused until the client is ready for installation, at which time installation labor will be invoiced upon completion. Product that is warehoused for over 6 months will be assessed a \$100/month/pallet storage fee beginning on the 7th month. - Sales tax is estimated and subject to change based upon the actual rate at time of invoicing. - Unless otherwise noted, client assumes all responsibility for permitting and utility locator services as necessary. - Customer is responsible for variations from customer supplied architectural drawings & landscapes. - Signature on this proposal constitutes approval from the client on supplied artwork/graphics. - Any credit balance(s) resulting from overpayment that remains on a credit account over 90 days will be applied to the oldest invoice(s) or to upcoming active order(s) and reflected on the following month's statement. - Invoices are due upon receipt. Any unpaid invoices are subject to late fees equal to 1.5% of the balance due per month (18% per year), collection fees and/or court costs.

Proposal Acceptance:

The above prices, specifications and conditions are hereby accepted. OnSight Industries, LLC is authorized to proceed with the project as stated. Payment will be made as outlined above.

Signature

Name

Date

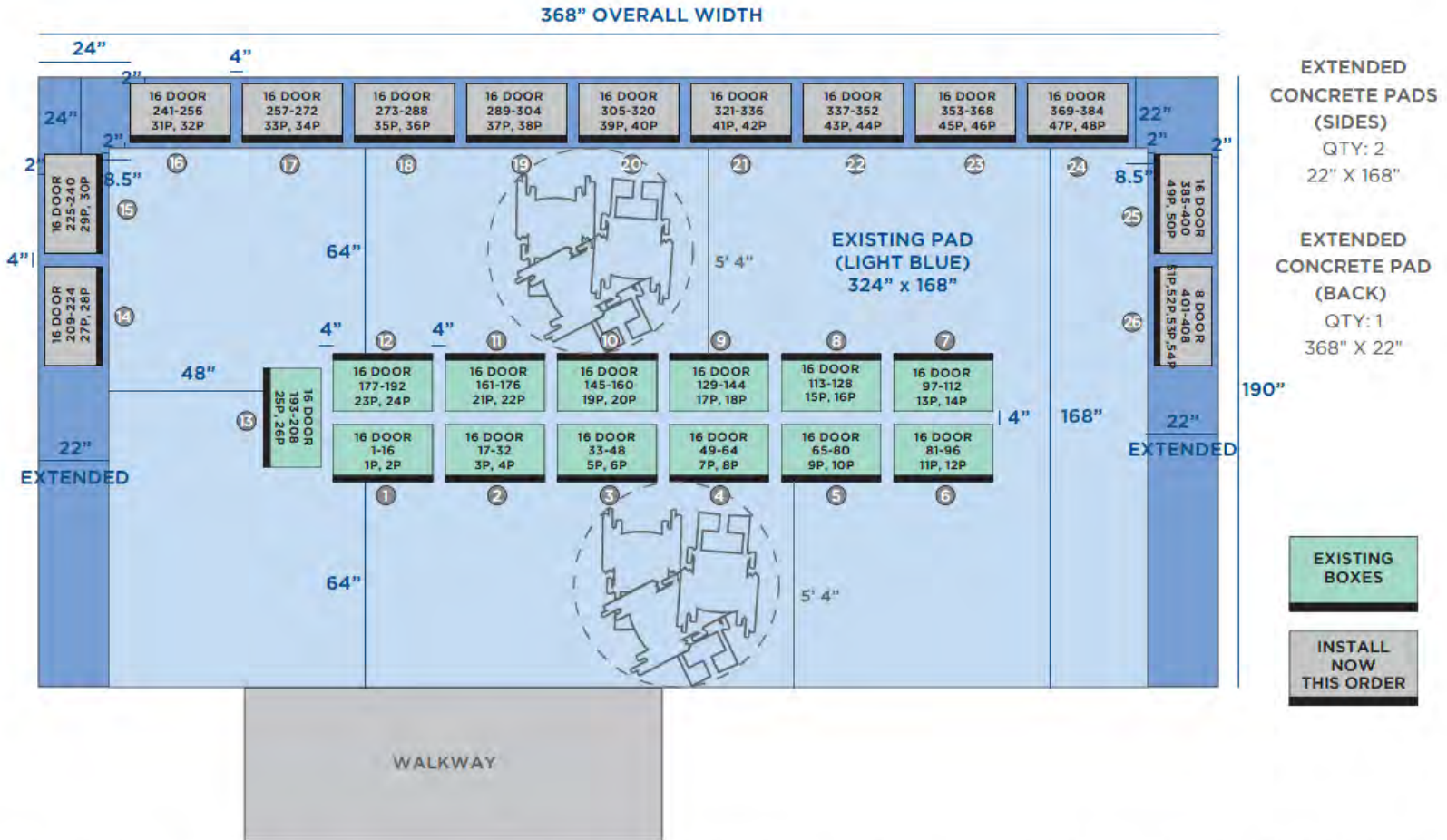

MEASUREMENTS FOR PAD CALCULATED USING RADIUS TURN REQUIREMENTS AS DEFINED BY USPS CLUSTER BOX DEVELOPERS GUIDE (APPENDIX D G1-2-0 E-E3), ACCESSIBLE ROUTE DEFINED BY AMERICANS WITH DISABILITIES ACT ACCESSIBILITY GUIDELINES FOR BUILDINGS AND FACILITIES (APPENDIX A TO PART 1191 - SECTION 4.3).

wo.382331 v.08.30.24

Six Mile Creek CDD - Trailmark - Phase 13

CBU Pad



L. KENNERLY
C. NORCROSS

This document is the property of OnSight Industries, LLC. The information and technology embodied herein shall not be reproduced or copied in whole or in part without previous authorization in writing from OnSight Industries, LLC. 900 Central Park Drive, Sanford, FL 32771 P.407.830.8861 F.407.830.5569 onsigthindustries.com

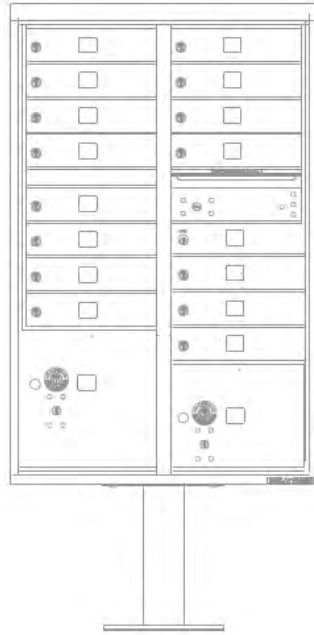

16 DOOR VITAL STANDARD - 1570-16

QTY: 12

2 PARCEL LOCKER/1 MAIL SLOT
SEQUENTIALLY NUMBERED

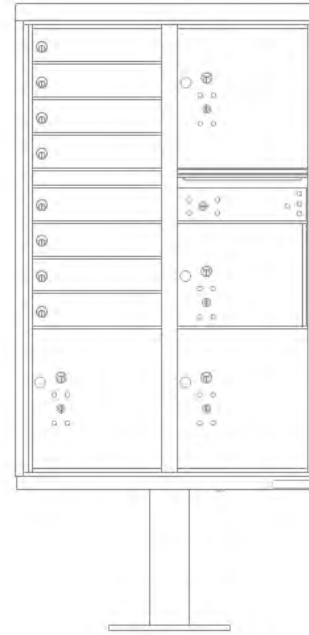

8 DOOR VITAL STANDARD - 1570-8T6

QTY: 1

4 PARCEL LOCKER/1 MAIL SLOT
SEQUENTIALLY NUMBERED

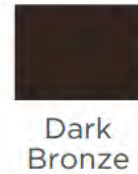

wo.382331 v.08.30.24

Six Mile Creek CDD - Trailmark - Phase 13

CBU



L. KENNERLY
C. NORCROSS

This document is the property of OnSight Industries, LLC. The information and technology embodied herein shall not be reproduced or copied in whole or in part without previous authorization in writing from OnSight Industries, LLC. 900 Central Park Drive, Sanford, FL 32771 P.407.830.8861 F.407.830.5569 on sightindustries.com

2.

AGREEMENT BETWEEN SIX MILE CREEK COMMUNITY DEVELOPMENT DISTRICT AND ONSIGHT INDUSTRIES, LLC TO FURNISH & INSTALL SIGNAGE

This Agreement is made and entered into by and between the following parties, and with an effective date of January 9, 2025:

SIX MILE CREEK COMMUNITY DEVELOPMENT DISTRICT, a local unit of special-purpose government established pursuant to Chapter 190, Florida Statutes, being situated in St. Johns County, Florida (“District”), and

ONSIGHT INDUSTRIES, LLC, a Florida limited liability company with an address of 900 Central Park Drive, Sanford, Florida 32771 (hereinafter “Contractor” and, with the District, the “Parties”).

RECITALS

WHEREAS, the District was established for the purpose of planning, financing, constructing, operating and/or maintaining certain infrastructure, including among other things, recreational amenities; and

WHEREAS, the District has a need to retain an independent contractor to furnish and provide the labor and materials necessary to install certain Signage as public improvements within the District as more particularly described herein; and

WHEREAS, Contractor represents that it is licensed and qualified to furnish Signage and provide the materials and perform the services as provided for herein and has agreed to provide the District with those materials and services identified in Contractor’s Proposal dated December 9, 2024, the related drawings, attached hereto as **Composite Exhibit A** and incorporated by reference herein (“Work”); and

WHEREAS, Contractor agrees to install the Signage and perform the Work described in **Composite Exhibit A**;

WHEREAS, the District desires to enter into this Agreement to have Contractor furnish the Signage and provide the materials and perform the services as more particularly described herein.

NOW, THEREFORE, in consideration of the recitals, agreements, and mutual covenants contained herein, and other good and valuable consideration, the receipt and sufficiency of which are hereby acknowledged by the Parties, the Parties agree as follows:

SECTION 1. RECITALS. The recitals so stated are true and correct and by this reference are incorporated into and form a material part of this Agreement.

SECTION 2. DUTIES AND COMPENSATION.

- A.** District agrees to use Contractor to provide the materials and services in accordance with the terms of this Agreement. The duties, obligations, and responsibilities of Contractor are to furnish Signage and provide the material, tools, skill, and labor necessary to install the Signage as delineated in **Composite Exhibit A** and herein. The installation shall be at the locations referenced in **Composite Exhibit A**.
- B.** The District shall pay Contractor a total amount of **\$4,183.50** (Four Thousand One Hundred Eighty-Three Dollars and Fifty Cents) for the Work as identified in **Composite Exhibit A**. Contractor shall invoice the District following the completion, and District's acceptance, of the Work. Compensation includes, but is not limited to, all permits, parts, materials and labor necessary to complete the Work as described herein. The District shall provide payment no later than forty five (45) days following the District's receipt of the invoice or as otherwise provided for under the Local Government Prompt Payment Act, Sections 218.70 et seq., Florida Statutes.
- C.** Contractor agrees to render a final invoice to the District, in writing, which shall be delivered or mailed to the District no later than the 5th day of the next succeeding month. The District, upon receipt of such timely invoice, shall pay the Contractor within thirty (30) days of receipt of such an invoice.
- D.** Contractor shall be solely responsible for the means, manner and methods by which its duties, obligations and responsibilities are met to the satisfaction of the District with the exception of those specifically provided for herein. All Work shall be performed in a neat and professional manner reasonably acceptable to the District and shall be in accordance with industry standards and best practices and this Agreement.
- E.** Should any work and/or services be required which are not specified in this Agreement or any addenda, but which are nevertheless necessary for the proper provision of Work to the District, such work or services shall be fully performed by the Contractor as if described and delineated in this Agreement without additional compensation provided therefore.
- F.** The Contractor agrees that the District shall not be liable for the payment of any additional services unless the District, through an authorized representative of the District, authorizes the Contractor, in writing, to perform such additional services.
- G.** Contractor shall use all due care to protect the property of the District, its residents and landowners from damage. Contractor agrees to repair any damage resulting from Contractor's activities and work within twenty-four (24) hours.

SECTION 3. TERMINATION. The District agrees that the Contractor may terminate this Agreement for cause by providing thirty (30) days written notice of termination to the District; provided, however, that the District shall be provided a reasonable opportunity to cure any failure under this Agreement. The Contractor agrees that the District may terminate this Agreement

immediately for cause by providing written notice of termination to the Contractor. The District shall provide fifteen (15) days written notice of termination without cause. Upon any termination of this Agreement, and as the Contractor's sole and exclusive remedy for any termination hereunder, the Contractor shall be entitled to payment for all Work rendered up until the effective termination of this Agreement, subject to whatever claims or off sets the District may have against the Contractor.

SECTION 4. WARRANTY. The Contractor warrants to the District that all materials furnished under this Agreement shall be new, and that all services and materials shall be of good quality, free from faults and defects. In addition to all manufacturer warranties for materials purchased for purposes of this Agreement, all Work, including but not limited to services and materials, provided by the Contractor pursuant to this Agreement shall be warranted for five years from the date of the final acceptance by the District of the Work.

SECTION 5. INSURANCE.

A. The Contractor shall maintain throughout the term of this Agreement the following insurance:

- (1)** Worker's Compensation Insurance in accordance with the laws of the State of Florida.
- (2)** Commercial General Liability Insurance covering the Contractor's legal liability for bodily injuries, with limits of not less than one million dollars (\$1,000,000) combined single limit bodily injury and property damage liability, and covering at least the following hazards:
 - (i)** Independent Contractors Coverage for bodily injury and property damage in connection with any subcontractors' operation.
- (3)** Employer's Liability Coverage with limits of at least one million dollars (\$1,000,000) per accident or disease.
- (4)** Automobile Liability Insurance for bodily injuries in limits of not less than one million dollars (\$1,000,000) combined single limit bodily injury and for property damage, providing coverage for any accident arising out of or resulting from the operation, maintenance, or use by the Contractor of any owned, non-owned, or hired automobiles, trailers, or other equipment required to be licensed.

B. The District, its staff, consultants and supervisors shall be named as additional insured. The Contractor shall furnish the District with the Certificate of Insurance evidencing compliance with this requirement. No certificate shall be acceptable to the District unless it provides that any change or termination within the policy periods of the insurance coverage, as certified, shall not be effective within thirty

(30) days of prior written notice to the District. Insurance coverage shall be from a reputable insurance carrier, licensed to conduct business in the State of Florida.

- C. If the Contractor fails to have secured and maintained the required insurance, the District has the right but not the obligation to secure such required insurance in which event the Contractor shall pay the cost for that required insurance and shall furnish, upon demand, all information that may be required in connection with the District's obtaining the required insurance.

SECTION 6. E-VERIFY REQUIREMENTS.

- A. The Contractor shall comply with and perform all applicable provisions of Section 448.095, *Florida Statutes*. Accordingly, beginning January 1, 2021, to the extent required by Florida Statute, Contractor shall register with and use the United States Department of Homeland Security's E-Verify system to verify the work authorization status of all newly hired employees. The District may terminate this Agreement immediately for cause if there is a good faith belief that the Contractor has knowingly violated Section 448.091, Florida Statutes.
- B. If the Contractor anticipates entering into agreements with a subcontractor for the Work, Contractor will not enter into the subcontractor agreement without first receiving an affidavit from the subcontractor regarding compliance with Section 448.095, *Florida Statutes*, and stating that the subcontractor does not employ, contract with, or subcontract with an unauthorized alien. Contractor shall maintain a copy of such affidavit for the duration of the agreement and provide a copy to the District upon request.
- C. In the event that the District has a good faith belief that a subcontractor has knowingly violated Section 448.095, *Florida Statutes*, but the Contractor has otherwise complied with its obligations hereunder, the District shall promptly notify the Contractor. The Contractor agrees to immediately terminate the agreement with the subcontractor upon notice from the District. Further, absent such notification from the District, the Contractor or any subcontractor who has a good faith belief that a person or entity with which it is contracting has knowingly violated s. 448.09(1), Florida Statutes, shall promptly terminate its agreement with such person or entity.
- D. By entering into this Agreement, the Contractor represents that no public employer has terminated a contract with the Contractor under Section 448.095(2)(c), *Florida Statutes*, within the year immediately preceding the date of this Agreement.

SECTION 7. INDEMNIFICATION.

- A. Obligations under this section shall include the payment of all settlements, judgments, damages, liquidated damages, penalties, forfeitures, back pay awards, court costs, arbitration and/or mediation costs, litigation expenses, attorney fees, paralegal expert witness fees (incurred in court, out of court, on appeal, or in bankruptcy proceedings),

any interest, expenses, damages, penalties, fines, or judgments against the District.

- B.** Contractor agrees to defend, indemnify, and hold harmless the District and its officers, agents, employees, successors, assigns, members, affiliates, or representatives from any and all liability, claims, actions, suits, liens, demands, costs, interest, expenses, damages, penalties, fines, judgments against the District, or loss or damage, whether monetary or otherwise, arising out of, wholly or in part by, or in connection with the Services to be performed by Contractor, its subcontractors, its employees and agents in connection with this Agreement, including litigation, mediation, arbitration, appellate, or settlement proceedings with respect thereto. Additionally, nothing in this Agreement requires Contractor to indemnify the District for the District's percentage of fault if the District is adjudged to be more than 50% at fault for any claims against the District and Contractor as jointly liable parties; however, Contractor shall indemnify the District for any and all percentage of fault attributable to Contractor for claims against the District, regardless whether the District is adjudged to be more or less than 50% at fault.

SECTION 8. COMPLIANCE WITH GOVERNMENTAL REGULATION. The Contractor shall keep, observe, and perform all requirements of applicable local, state, and federal laws, rules, regulations, or ordinances. If the Contractor fails to notify the District in writing within five (5) days of the receipt of any notice, order, required to comply notice, or a report of a violation or an alleged violation, made by any local, state, or federal governmental body or agency or subdivision thereof with respect to the services being rendered under this Agreement or any action of the Contractor or any of its agents, servants, employees, or materialmen, or with respect to terms, wages, hours, conditions of employment, safety appliances, or any other requirements applicable to provision of services, or fails to comply with any requirement of such agency within five (5) days after receipt of any such notice, order, request to comply notice, or report of a violation or an alleged violation, the District may terminate this Agreement, such termination to be effective immediately upon the giving of notice of termination.

SECTION 9. LIENS AND CLAIMS. The Contractor shall promptly and properly pay for all labor employed, materials purchased, and equipment hired by it to perform under this Agreement. The Contractor shall keep the District's property free from any materialmen's or mechanic's liens and claims or notices in respect to such liens and claims, which arise by reason of the Contractor's performance under this Agreement, and the Contractor shall immediately discharge any such claim or lien. In the event that the Contractor does not pay or satisfy such claim or lien within three (3) business days after the filing of notice thereof, the District, in addition to any and all other remedies available under this Agreement, may terminate this Agreement to be effective immediately upon the giving of notice of termination.

SECTION 10. LIMITATIONS ON GOVERNMENTAL LIABILITY. Nothing in this Agreement shall be deemed as a waiver of the District's sovereign immunity or the District's limits of liability as set forth in Section 768.28, Florida Statutes or other law, and nothing in this Agreement shall inure to the benefit of any third party for the purpose of allowing any claim which would otherwise be barred under such limitations of liability or by operation of law.

SECTION 11. NO THIRD PARTY BENEFICIARIES. This Agreement is solely for the benefit of the formal Parties herein and no right or cause of action shall accrue upon or by reason hereof, to or for the benefit of any third party not a formal party hereto. Nothing in this Agreement expressed or implied is intended or shall be construed to confer upon any person or corporation other than the Parties hereto any right, remedy or claim under or by reason of this Agreement or any provisions or conditions hereof; and all of the provisions, representations, covenants and conditions herein contained shall inure to the sole benefit of and shall be binding upon the Parties hereto and their respective representatives, successors and assigns.

SECTION 12. INDEPENDENT CONTRACTOR. In all matters relating to this Agreement, the Contractor shall be acting as an independent contractor. Neither the Contractor nor employees of the Contractor, if there are any, are employees of the District under the meaning or application of any Federal or State Unemployment or Insurance Laws or Old Age Laws or otherwise. The Contractor agrees to assume all liabilities or obligations imposed by any one or more of such laws with respect to employees of the Contractor, if there are any, in the performance of this Agreement. The Contractor shall not have any authority to assume or create any obligation, express or implied, on behalf of the District and the Contractor shall have no authority to represent the District as an agent, employee, or in any other capacity, unless otherwise set forth in this Agreement.

SECTION 13. AGREEMENT. This instrument shall constitute the final and complete expression of the agreement between the District and Contractor relating to the subject matter of this Agreement. None of the provisions of Exhibit A shall apply to this Agreement and Exhibit A shall not be incorporated herein, except that Exhibit A is applicable to the extent that it states the Work's scope of services for the labor and materials to be provided under this Agreement.

SECTION 14. AMENDMENTS. Amendments to and waivers of the provisions contained in this Agreement may be made only by an instrument in writing which is executed by both the District and Contractor.

SECTION 15. AUTHORIZATION. The execution of this Agreement has been duly authorized by the appropriate body or official of the District and Contractor, both the District and Contractor have complied with all the requirements of law, and both the District and Contractor have full power and authority to comply with the terms and provisions of this Agreement.

SECTION 16. NOTICES. All notices, requests, consents and other communications under this Agreement ("Notices") shall be in writing and shall be hand delivered, mailed by First Class Mail, postage prepaid, or sent overnight delivery service, to the Parties, as follows:

A. If to District: Six Mile Creek Community Development District
475 West Town Place, Suite 114
St. Augustine, Florida 32092
Attn: District Manager

With a copy to: Kutak Rock LLP
107 W. College Ave.
Tallahassee, Florida 32301
Attn: District Counsel

B. If to the Contractor: Onsight, Inc.
900 Central Park Drive
Sanford, Florida 32771
Attn: Dan Kristoff

Except as otherwise provided in this Agreement, any Notice shall be deemed received only upon actual delivery at the address set forth above. Notices delivered after 5:00 p.m. (at the place of delivery) or on a non-business day, shall be deemed received on the next business day. If any time for giving Notice contained in this Agreement would otherwise expire on a non-business day, the Notice period shall be extended to the next succeeding business day. Saturdays, Sundays, and legal holidays recognized by the United States government shall not be regarded as business days. Counsel for District and counsel for Contractor may deliver Notice on behalf of the District and Contractor. Any party or other person to whom Notices are to be sent or copied may notify the other Parties and addressees of any change in name or address to which Notices shall be sent by providing the same on five (5) days written notice to the Parties and addressees set forth in this Agreement.

SECTION 17. ENFORCEMENT OF AGREEMENT. In the event that either the District or Contractor is required to enforce this Agreement by court proceedings or otherwise, then the prevailing party shall be entitled to recover all fees and costs incurred, including reasonable attorneys' fees and costs for trial, alternative dispute resolution, or appellate proceedings.

SECTION 18. CONTROLLING LAW AND VENUE. This Agreement and the provisions contained in this Agreement shall be construed, interpreted, and controlled according to the laws of the State of Florida. All actions and disputes shall be brought in the proper court and venue, which shall be St. Johns County, Florida.

SECTION 19. PUBLIC RECORDS. Contractor understands and agrees that all documents of any kind provided to the District in connection with this Agreement may be public records, and, accordingly, Contractor agrees to comply with all applicable provisions of Florida law in handling such records, including but not limited to Section 119.0701, *Florida Statutes*. Contractor acknowledges that the designated public records custodian for the District is **Jim Oliver**, District Manager ("Public Records Custodian"). Among other requirements and to the extent applicable by law, the Contractor shall 1) keep and maintain public records required by the District to perform the service; 2) upon request by the Public Records Custodian, provide the District with the requested public records or allow the records to be inspected or copied within a reasonable time period at a cost that does not exceed the cost provided in Chapter 119, *Florida Statutes*; 3) ensure that public records which are exempt or confidential, and exempt from public records disclosure requirements, are not disclosed except as authorized by law for the duration of the contract term and following the contract term if the Contractor does not transfer the records to the Public Records

Custodian of the District; and 4) upon completion of the contract, transfer to the District, at no cost, all public records in Contractor's possession or, alternatively, keep, maintain and meet all applicable requirements for retaining public records pursuant to Florida laws. When such public records are transferred by the Contractor, the Contractor shall destroy any duplicate public records that are exempt or confidential and exempt from public records disclosure requirements. All records stored electronically must be provided to the District in a format that is compatible with Microsoft Word or Adobe PDF formats.

IF THE CONTRACTOR HAS QUESTIONS REGARDING THE APPLICATION OF CHAPTER 119, *FLORIDA STATUTES*, TO THE CONTRACTOR'S DUTY TO PROVIDE PUBLIC RECORDS RELATING TO THIS CONTRACT, CONTACT THE CUSTODIAN OF PUBLIC RECORDS AT 475 WEST TOWN PLACE, SUITE 114, ST. AUGUSTINE, FLORIDA 32092, PHONE: (904) 940-5850, E-MAIL JOLIVER@GMSNF.COM

SECTION 20. SEVERABILITY. The invalidity or unenforceability of any one or more provisions of this Agreement shall not affect the validity or enforceability of the remaining portions of this Agreement, or any part of this Agreement not held to be invalid or unenforceable.

SECTION 21. HEADINGS FOR CONVENIENCE ONLY. The descriptive headings in this Agreement are for convenience only and shall neither control nor affect the meaning or construction of any of the provisions of this Agreement.

SECTION 22. COUNTERPARTS. This Agreement may be executed in any number of counterparts, each of which when executed and delivered shall be an original; however, all such counterparts together shall constitute, but one and the same instrument.

SECTION 23. NEGOTIATION AT ARM'S LENGTH. This Agreement has been negotiated fully between the Parties as an arm's length transaction. The Parties participated fully in the preparation of this Agreement and received the advice of counsel. In the case of a dispute concerning the interpretation of any provision of this Agreement, all Parties are deemed to have drafted, chosen and selected the language, and the doubtful language will not be interpreted or construed against any party.

SECTION 24. ASSIGNMENT. Neither party may assign this Agreement or any monies to become due hereunder without the prior written approval of the other party.

SECTION 25. AGREEMENT CONTROLS. To the extent that any of the provisions in the attached Exhibit A and this Agreement conflict, the terms of this Agreement controls.

SECTION 26. COMPLIANCE WITH SECTION 20.055, *FLORIDA STATUTES*. The Contractor agrees to comply with Section 20.055(5), *Florida Statutes*, to cooperate with the inspector general in any investigation, audit, inspection, review, or hearing pursuant to such section

and to incorporate in all subcontracts the obligation to comply with Section 20.055(5), *Florida Statutes*.

SECTION 27. SCRUTINIZED COMPANIES STATEMENT. Contractor certifies it: (i) is not in violation of Section 287.135, *Florida Statutes*; (ii) is not on the Scrutinized Companies with Activities in Sudan List; (iii) is not on the Scrutinized Companies with Activities in the Iran Petroleum Energy Sector List; (iv) does not have business operations in Cuba or Syria; (v) is not on the Scrutinized Companies that Boycott Israel List; and (vi) is not participating in a boycott of Israel. If the Contractor is found to have submitted a false statement with regards to the prior sentence, has been placed on the Scrutinized Companies with Activities in Sudan List, the Scrutinized Companies with Activities in the Iran Petroleum Energy Sector List, or the Scrutinized Companies that Boycott Israel List, has engaged in business operations in Cuba or Syria, and/or has engaged in a boycott of Israel, the District may immediately terminate the Contract.

[CONTINUED ON FOLLOWING PAGE]

IN WITNESS WHEREOF, the Parties hereto have signed this Agreement to be effective on the day and year first written above.

ATTEST:

**SIX MILE CREEK COMMUNITY
DEVELOPMENT DISTRICT**

Signed by:

Daniel Laughlin

Secretary/Assistant Secretary

Signed by:
Michelle Sutton

Chairperson, Board of Supervisors

WITNESS:

ONSIGHT INDUSTRIES, LLC

Signed by:

Brad Osleger

By: Caroline Kennerly

By: Brad Osleger

Its: President

Composite Exhibit A: Contractor's Proposal and Drawings

Composite Exhibit A
Contractor's Proposal and Drawings



PROPOSAL
W000388112

OnSight Industries, LLC
900 Central Park Dr
Sanford FL 32771

Written By: LEE KENNERLY

Date: 12/9/2024

Proposal: W000388112

Bill To:

SIX MILE CREEK CDD
475 WEST TOWN PLACE
SUITE 114
ST AUGUSTINE FL 32092

Location:

TRAILMARK
475 WEST TOWN PLACE SUITE 114
SAINT AUGUSTINE FL 32092

Project Name: PH 13 STREET SIGNS

Line	Item	U/M	Unit Price	Qty	Net Amount
1	ITEM-STREET SIGNAGE-M001819 STREET SIGNAGE CUSTOM SIGNS 1-3	EA	886.50	3.000	2,659.50
2	LABOR/INSTALL JACKSONVILLE LOCAL 30-45 LABOR / INSTALLATION INSTALL JACKSONVILLE LOCAL 30-45	EA	550.00	1.000	550.00
3	ITEM-STREET SIGNAGE-M001819 STREET SIGNAGE CUSTOM SIGNS 4	EA	974.00	1.000	974.00



PROPOSAL

W000388112

Line	Item	U/M	Unit Price	Qty	Net Amount
					Pre-Tax Total: 4,183.50
					Sales Tax: 0.00
					Total: 4,183.50

Terms and Conditions:

- All agreements are contingent upon delays and material cost increases beyond our control. Manufacturing cost increases incurred after quotation and prior to a work order being submitted to production will be passed through to the customer. In this scenario, the project will be required for customer approval. - Pricing in this proposal is subject to acceptance within 14 days and is void thereafter. - Depending upon the agreed credit terms, a deposit may be required before work is to commence. - If a deposit is to be paid by credit card, you authorize OnSight Industries, LLC to charge 50% of the total project cost upfront and the balance of the project upon completion. - Any labor and installation pricing is approximate and subject to change based upon actual time incurred. - Delivery/installation postponement will result in the client being progress billed for completed product. At this time, title for the product will transfer to the client. Client agrees to pay progress bill invoice upon receipt. Product will be warehoused until the client is ready for installation, at which time installation labor will be invoiced upon completion. Product that is warehoused for over 6 months will be assessed a \$100/month/pallet storage fee beginning on the 7th month. - Sales tax is estimated and subject to change based upon the actual rate at time of invoicing. - Unless otherwise noted, client assumes all responsibility for permitting and utility locator services as necessary. - Customer is responsible for variations from customer supplied architectural drawings & landscapes. - Signature on this proposal constitutes approval from the client on supplied artwork/graphics. - Any credit balance(s) resulting from overpayment that remains on a credit account over 30 days will be applied to the oldest invoice(s) or to upcoming active order(s) and reflected on the following month's statement. - Invoices are due upon receipt. Any unpaid invoices are subject to late fees equal to 1.5% of the balance due per month (18% per year), collection fees and/or court costs.

Proposal Acceptance:

The above prices, specifications and conditions are hereby accepted. OnSight Industries, LLC is authorized to proceed with the project as stated. Payment will be made as outlined above.

_____ Signature

_____ Name

_____ Date

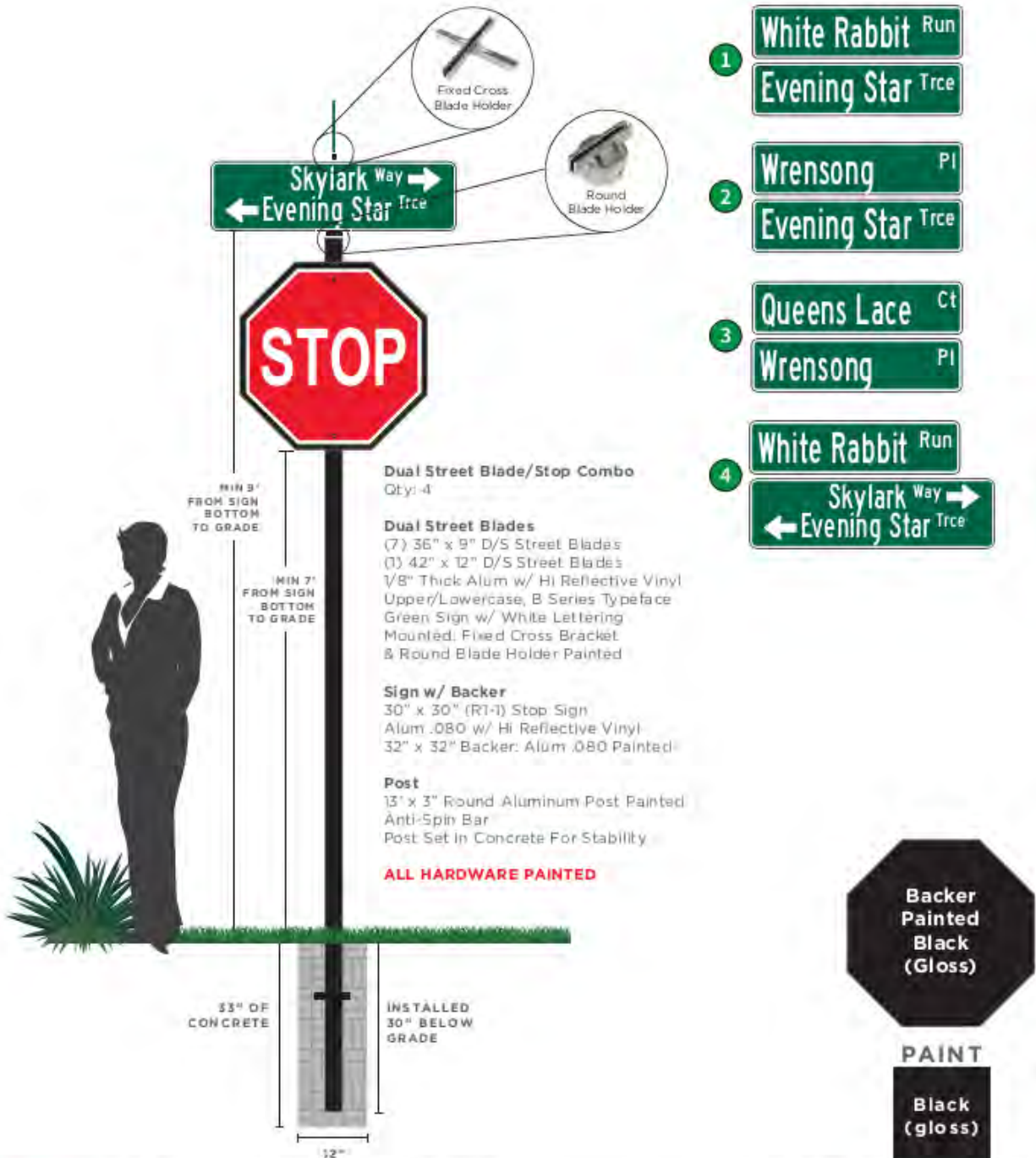

wa.389112 v.11.25.24

Six Mile Creek CDD - Trailmark

Dual Street Blade/Stop Combo



L. KENNERLY
C. GOSNELL

This document is the property of OnSight Industries, LLC. The information and technology (invoiced herein) shall not be reproduced or copied in whole or in part without previous authorization in writing from OnSight Industries, LLC, 900 Central Park Drive, Sanford, FL 32771 P:407.830.8851 F:407.830.8869 onsigHindustries.com



wo.388112 v.11.25.24

Six Mile Creek CDD - Trailmark

Map 1



L. KENNERLY
C. GOSNELL

This document is the property of OnSight Industries, LLC. The information and technology embodied herein shall not be reproduced or copied in whole or in part without previous authorization in writing from OnSight Industries, LLC. 900 Central Park Drive, Sanford, FL 32771 P.407.830.8861 F.407.830.5569 on sightindustries.com

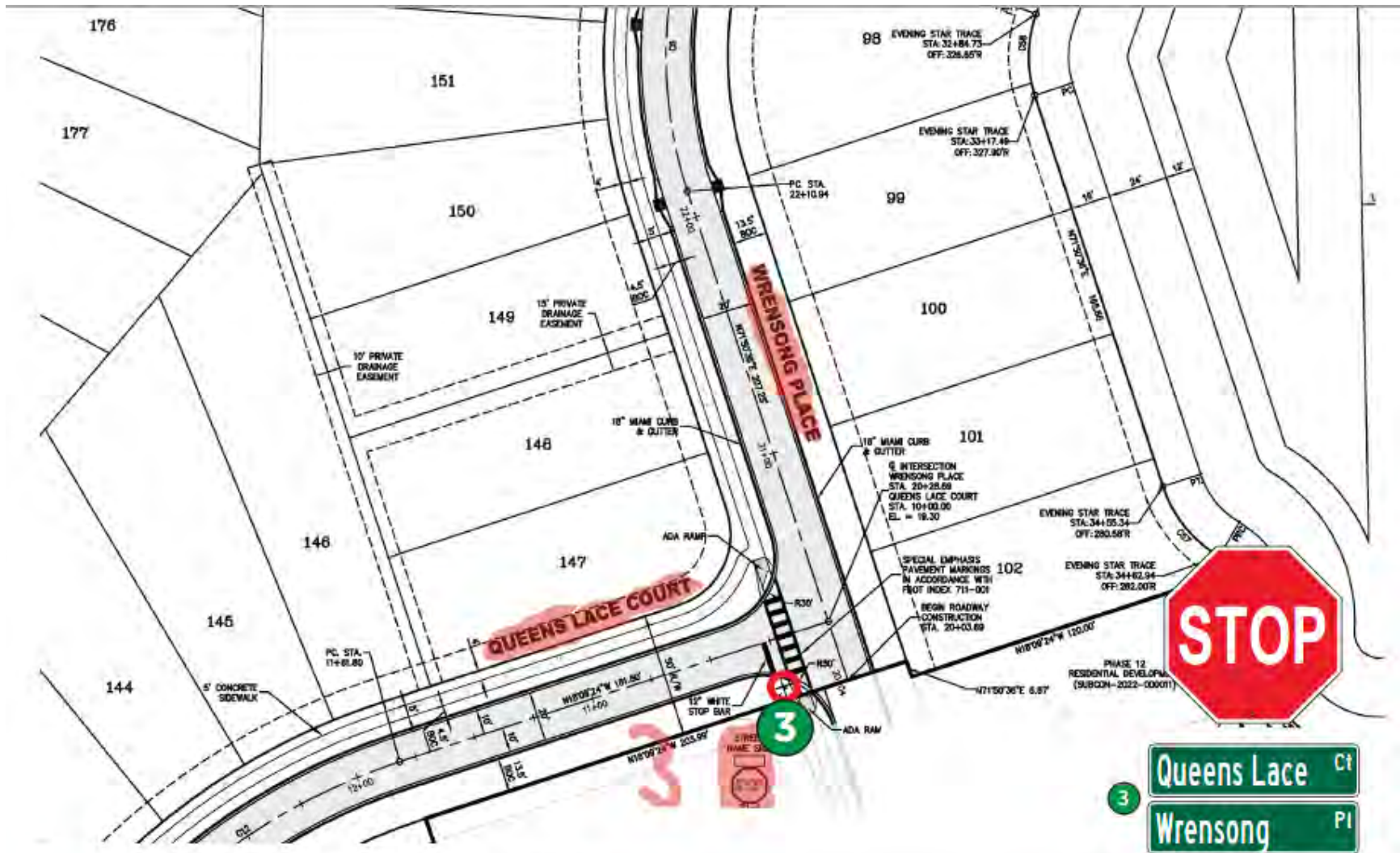

wa.388112 v.11.25.24

Six Mile Creek CDD - Trailmark

Map 2



L. KENNERLY
C. GOSNELL

This document is the property of OnSight Industries, LLC. The information and technology embodied herein shall not be reproduced or copied in whole or in part without previous authorization in writing from OnSight Industries, LLC. 900 Central Park Drive, Sanford, FL 32771 P.407.830.8861 F.407.830.5569 onightindustries.com

3.



Florida Power & Light Company, 303 Hastings Rd., St Augustine, FL 32084
904-824-7617

September 13th, 2024

Six Mile Creek CDD
475 West Town Place, Suite 114
St. Augustine, FL 32092

Re: Cost to provide 120/240v single phase and three phase service to Trailmark Phases 13 – (197 lots)

Dear Nick,

We at FPL appreciate the opportunity to work with you in your new construction project at Trailmark. The cost to provide underground electric service to you has been calculated and is determined by FPL's approved electric tariffs and by the plans you have provided.

The cost of this installation is \$0.00 and is broken down as follows:

This is for Differential Cost between Overhead and Underground Distribution System with customer installing all FPL provided materials for FPL distribution system-conduit, primary splice boxes, handholes, trench, pads, locate wire, 90's and 45's and locating devices as needed to serve lots along with conduit for service to house from lot corner to meter can. FPL will supply and pull all conductors for distribution, secondary, service and streetlights.

I have enclosed a list of FPL approved contractors. You can use whoever you want to install FPL Distribution System. If you choose to use someone not on our list, a charge of \$181,909.68 will be charged up front and a credit of \$181,909.68 will be given back after FPL has pulled in its distribution system. If discrepancies from FPL design are discovered and your contractor cannot fix, FPL will fix and deduct cost from credit. (credits cannot exceed charges)

Along with your payment the following will be required to help keep your project on schedule:

- **Signed** - Underground Distribution Facilities Installation Agreement
- **Signed** – Underground Road/Pavement Crossing Agreement
- **Signed** - Notification of FPL Facilities
- **Signed** - Transformer Pad Location and Specification
- **Copy of Recorded Plat** – Preliminary Plat will need to be provided for FPL review of easements before materials are released

Your construction project is very important to FPL. I will be communicating with you throughout the construction process and will work with you to keep it on schedule. FPL will install PM TX approximately 6 to 8 weeks after receipt of recorded easement, agreements, contribution and installation of FPL conduit.

Sincerely,

A handwritten signature in black ink, appearing to read 'Daniel Terza', written over a horizontal line.

Daniel Terza
Senior Engineer
904-824-7617

September 13th, 2024

Six Mile Creek CDD
475 West Town Place, Suite 114
St. Augustine, FL 32092

Exhibit "A" charges for Tralimark 13

URD Charges:

Tariff 10.3.2.a.2(1) – Contribution – per service lateral – 197 x \$0.00 = \$0.00
Tariff 10.3.2.b – Applicants contribution (feeder) – \$32.72 x 3,862' ft = \$126,364.64
Tariff 10.3.2.b – Switch package - \$43,680.63 x 1 = \$43,680.63

Credits (Cannot exceed charges)

Tariff 10.3.3.a.2 – Credit – trench/backfill backbone and service – 197 x (\$621.95) = (\$122,524.15)
Tariff 10.3.3.b.2 – Credit – install FPL conduit backbone and service– 197 x (\$211.8) = (\$41,586.70)
Tariff 10.3.3.d – Credit – install conduit per ft of 2" pvc – 3,682' x (\$0.80) = (\$4,123.84)
Tariff 10.3.3.e – Credit – install FPL feeder splice box – 5 x (\$886.68) = (\$4,433.40)
Tariff 10.3.3.f – Credit – install FPL primary splice box – 13 x (\$310.50) = (\$4,036.50)
Tariff 10.3.3.g – Credit - installing 17" secondary handhole – 6 x (\$28.81) = (\$172.86)
Tariff 10.3.3.g – Credit - installing 24" or 30" secondary handhole – 23 x (\$81.63) = (\$1,877.49)
Tariff 10.3.3.h – Credit - installing Concrete Pad – 30 x (\$80.03) = (\$2,400.90)
Tariff 10.3.3.j – Credit – install FPL feeder switch pad – 1 x (\$753.84) = (\$753.84)

Total Charges = \$170,0145.27
Total Credits = \$181,909.68

Credits (Cannot exceed charges)
Credits do not apply to bore differential cost

Balance due if using FPL approved contractor = \$0.00



WR#13285565

UNDERGROUND DISTRIBUTION FACILITIES INSTALLATION AGREEMENT

This Agreement, made this 13th day of September, 2024 by and between Six Mile Creek CDD (hereinafter called the Customer) and FLORIDA POWER & LIGHT COMPANY, a corporation organized and existing under the laws of the State of Florida (hereinafter called FPL).

WITNESSETH:

Whereas, the Customer has applied to FPL for underground distribution facilities to be installed on Customer's property known as Trailmark 13 located in St Augustine/St Johns.
(City/County)

That for and in consideration of the covenants and agreements herein set forth, the parties hereto covenant and agree as follows:

1. The Customer shall pay FPL a Contribution in Aid of Construction of \$170,045.27 (the total Contribution) to cover the differential cost between an underground and an overhead system. This is based on the currently effective tariff filed with the Florida Public Service Commission by FPL and is more particularly described on Exhibit A attached hereto.
2. That a credit of \$181,909.68 shall be provided to the Customer for trenching, backfilling, installation of Company provided conduit and other work, as shown on Exhibit B, if applicable, and approved by FPL. If such credit applies, the resulting Contribution cash payment shall be \$0.00.
3. The contribution and credit are subject to adjustment when FPL's tariff is revised by the Florida Public Service Commission and the Customer has requested FPL to delay FPL's scheduled date of installation. Any additional costs caused by a Customer's change in the Customer's plans submitted to FPL on which the contribution was based shall be paid for by the Customer. The contribution does not include the cost of conversion of any existing overhead lines to underground or the relocation of any existing overhead or underground facilities to serve the property identified above.
4. That the Contribution provides for 120/240 volt, single and three phase (120/240 volt, single phase for URD Subdivisions) underground electrical service with facilities located on private property in easements as required by FPL. The contribution is based on employment of rapid production techniques and cooperation to eliminate conflicts with other utilities. Underground service, secondary, and primary conductors are to be of standard FPL design, in conduit, and with above-grade appurtenances.
5. That the payment of the Contribution does not waive any provisions of FPL's Electric Tariff.

If the property is subject to an underground ordinance, FPL shall notify the appropriate governmental agency that satisfactory arrangements have been made with the Customer as specified by FPL.

Title to and ownership of the facilities installed as a result of this agreement shall at all times remain the property of FPL.

6. That good and sufficient easements, including legal descriptions and survey work to produce such easements, and mortgage subordinations required by FPL for the installation and maintenance of its electric distribution facilities must be granted or obtained, and recorded, at no cost to FPL, prior to trenching, installation and/or construction of FPL facilities. FPL may require mortgage subordinations when the Customer's property, on which FPL will install its facilities, is mortgaged and (1) there are no provisions in the mortgage that the lien of the mortgage will be subordinate to utility easements, (2) FPL's easement has not been recorded prior to the recordation of the mortgage, (3) FPL's facilities are or will be used to serve other parcels of property, or (4) other circumstances exist which FPL determines would make such a subordination necessary.
 - a) The Customer shall furnish FPL a copy of the deed or other suitable document, which contains a full legal description, and exact name of the legal owner to be used when an easement is prepared, as required by FPL.
 - b) The Customer shall furnish drawings, satisfactory to FPL, showing the location of existing and proposed structures on the Customer's construction site, as required by FPL.
 - c) Should for any reason, except for the sole error of FPL, FPL's facilities not be constructed within the easement, FPL may require the customer to grant new easements and obtain any necessary mortgage subordinations to cover FPL's installed facilities, at no cost to FPL, and FPL will release the existing easement. Mortgage subordinations will be necessary in this context when 1) the Customer's property on which FPL will install its facilities is mortgaged, 2) there are no provisions in the mortgage for subordination of the lien of the mortgage to utility easements, or 3) FPL's facilities are or will be used to serve other parcels of property.

- 7. Before FPL can begin its engineering work on the underground electric distribution facilities, the Customer shall provide FPL with the following:
 - a) Paving, grading, and drainage plans showing all surface and sub-surface drainage satisfactory to FPL,
 - b) A construction schedule,
 - c) An estimate of when electric service will be required, and
 - d) Copies of the Customer's final construction plans as well as other construction drawings (plot, site, sewage, electrical, etc.) requested by FPL. Plans provided by the Customer must be either recorded by the circuit clerk or other recording officer or prepared and certified as meeting the requirements for recording (except approval by the governing body) by a registered land surveyor.
- 8. Prior to FPL construction pursuant to this agreement, the Customer shall:
 - a) Clear the FPL easement on the Customer's property of tree stumps, all trees, and other obstructions that conflict with construction, including the drainage of all flooded areas. The Customer shall be responsible for clearing, compacting, boulder and large rock removal, stump removal, paving and addressing other special conditions. The easement shall be graded to within six inches of final grade with soil stabilized.
 - b) Provide property line and corner stakes, designated by a licensed surveyor, to establish a reference for locating the underground cable trench route in the easement and additional reference points when required by FPL. Also, the Customer shall provide stakes identifying the location, depth, size and type facility of all non-FPL underground facilities within or near the easement where FPL distribution facilities will be installed. The Customer shall maintain these stakes, and if any of these stakes are lost, destroyed or moved and FPL requires their use, the Customer shall replace the stakes at no cost to FPL, unless the stakes are lost, destroyed or moved by an agent, employee, contractor or subcontractor of FPL, in which case FPL will pay the Customer the cost of replacing the stakes.
 - c) It is further understood and agreed that subsequent relocation or repair of the FPL system, once installed, will be paid by the Customer if said relocation or repair is a result of a change in the grading by the Customer or any of the Customer's contractors or subcontractors from the time the underground facilities were installed; and, that subsequent repair to FPL's system, once installed, will be paid by the Customer if said repair is a result of damage caused by the Customer or any of the Customer's contractors or subcontractors.
 - d) Provide sufficient and timely advance notice (30 days) as required by FPL, for FPL to install its underground distribution facilities prior to the installation of paving, landscaping, sodding, sprinkler systems, or other surface obstructions. In the absence of sufficient coordination, as determined by FPL, by the Customer, all additional costs for trenching and backfilling shall be paid by the Customer, and none of the costs of restoring paving, landscaping, grass, sprinkler systems and all other surface obstructions to their original condition, should they be installed prior to FPL's facilities, shall be borne by FPL.
 - e) Pay for all additional costs incurred by FPL which may include, but are not limited to, engineering design, administration and relocation expenses, due to changes made subsequent to this agreement on the subdivision or development layout or grade.
 - f) Provide applicable trenching, backfilling, installation of Company provided conduit and other work in accordance with FPL specifications more particularly described on Exhibit B attached hereto. At the discretion of FPL, either correct any discrepancies, within two (2) working days, found in the installation that are inconsistent with the instructions and specifications attached to this agreement or pay the associated cost to correct the installation within thirty (30) days of receiving the associated bill, and in either case, reimburse FPL for costs associated with lost crew time due to such discrepancies.
 - g) Provide a meter enclosure, downpipe and ell which meet all applicable codes and FPL specifications, and which will accommodate FPL's service cable size and design. These items must be confirmed with FPL prior to purchase. FPL will not be responsible for costs involved in modifying or replacing items which do not meet the above criteria.
- 9. FPL shall:
 - a) Provide the Customer with a plan showing the location of all FPL underground facilities, point of delivery, and transformer locations and specifications required by FPL and to be adhered to by the Customer.
 - b) Install, own, and maintain the electric distribution facilities up to the designated point of delivery except when otherwise noted.
 - c) Request the Customer to participate in a pre-construction conference with the Customer's contractors, the FPL representatives and other utilities within six (6) weeks of the start of construction. At the pre-construction conference, FPL shall provide the Customer with an estimate of the date when service may be provided.
- 10. This Agreement is subject to FPL's Electric Tariff, including but not limited to the General Rules and Regulations for Electric Service and the Rules of the Florida Public Service Commission, as they are now written, or as they may be revised, amended or supplemented.
- 11. This agreement shall inure to the benefit of, and be binding upon, the successors and assigns of the Customer and FPL.

The Customer and FPL will coordinate closely in fulfilling obligations in order to avoid delays in providing permanent electric service at the time of the Customer's receipt of a certificate of occupancy.

Accepted:

 9-13-24
 For FPL (Date)

Signed by:

Accepted: 
 Initial:
 EEA51DA3E10477... (Date)
 Customer:  (Date)

Witness Signed by:

Witness:  (Date)
 Witness: A72E7324E1... (Date)



WR#133285565

UNDERGROUND ROAD/PAVEMENT CROSSING AGREEMENT

This Agreement, made this 13th day of September, 2024, by and between Six Mile Creek CDD (hereinafter called the Customer) and Florida Power & Light Company, a corporation organized and existing under the laws of the State of Florida (hereinafter called FPL).

WHEREAS the Customer has requested the pre-approval of the location and installation of underground distribution facilities to be located under a dedicated roadbed described as follows: White Rabbit Run, Skylark Way, Wrensong Place, Queens Lace Court, Evening Star Trace

WITNESSETH

That, for and in consideration of the covenants and agreements herein set forth, the parties hereto covenant and agree as follows:

1. The Customer shall:

- a) Install conduit and cable markers provided by FPL in accordance with the instructions and specifications attached to this Agreement,
- b) provide reasonable notification of the conduit installation date and allow FPL to inspect the conduit installation prior to backfilling the trench created for the underground distribution facility,
- c) at the request of FPL, correct any discrepancies found in the installation that are inconsistent with the instructions and specifications attached to this Agreement, or pay FPL the associated cost to correct the installation, and
- d) provide survey control points for FPL to stake the road/pavement crossing.

2. FPL shall:

- a) provide instructions and specifications for the installation of FPL-provided conduit,
- b) provide conduit and cable markers to the Customer for the installation of underground facilities at the specified road/pavement crossing,
- c) provide staking for the Customer at the specified road/pavement crossing,
- d) inspect the underground distribution facilities prior to the backfilling of the trench to insure proper installation of said facilities, and
- e) apply a credit in the amount of \$181,909.68 in the event that the Customer has made or has agreed to make a contribution in aid of construction for other underground distribution facilities associated with this Agreement.

3. This agreement is subject to FPL's General Rules and Regulations for Electric Service and the Rules of the Florida Public Service Commission.

IN WITNESS WHEREOF the parties hereto have caused the Agreement to be duly executed to be effective as of the day and year first written above:

Signed by:
 APPLICANT: Michelle Sutton
 SIGNED EEAF51DASF10477...
 NAME Michelle Sutton
 TITLE Chair

FPL:
 SIGNED [Signature]
 NAME Daniel Terza
 TITLE Senior Engineer

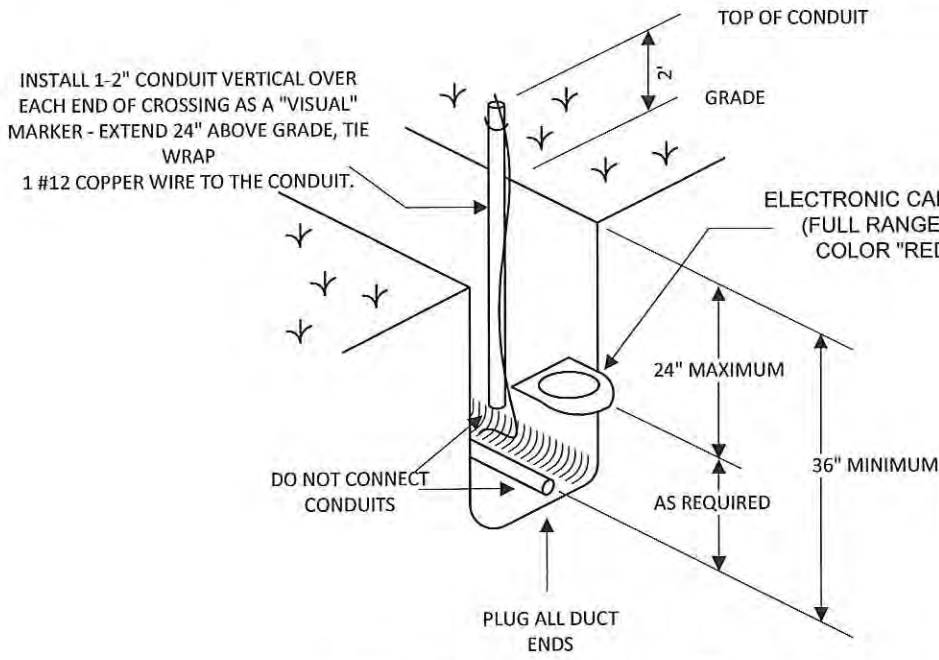
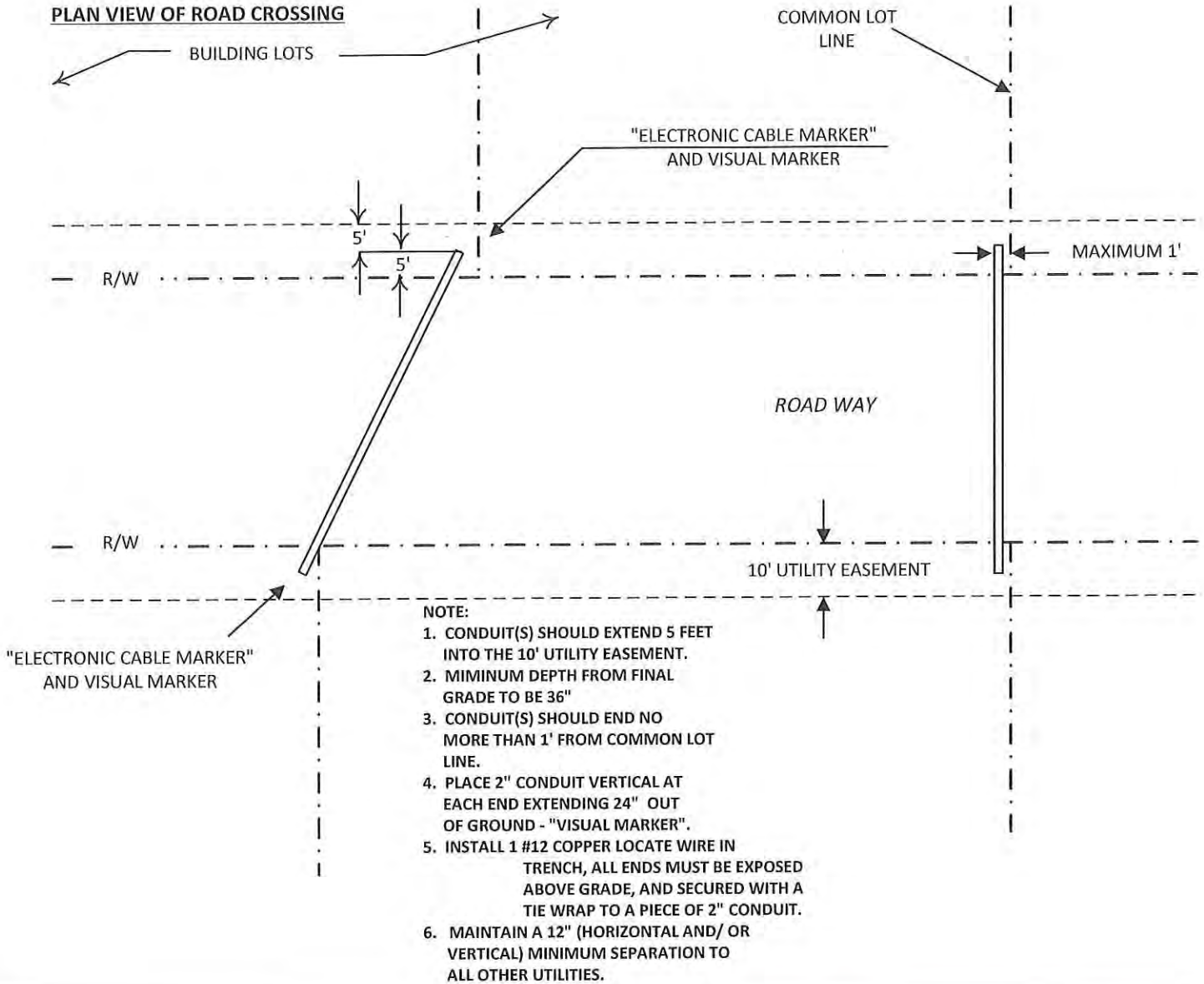

DUCT END FOR ROAD CROSSINGS

PROJECT	TRAILMARK 13
FPL JOB NO.	13285565
FPL REP.	DANIEL TERZA
PHONE NO.	904-824-7617



NOTIFICATION OF FPL FACILITIES

Customer/Agency SIX MILE CREEK CDD
 Developer/Contractor Name GREENPOINTE COMMUNITIES, LLC
 Location of Project TRAILMARK DR
 FPL Representative DANIEL TERZA
 Developer/Contractor Representative NICK McKENNA

Date of Meeting/Contact: 05/21/2024
 Project Number/Name: TRAILMARK 13
 City: ST. AUGUSTINE
 Phone: 904-824-7617
 Work Request #/Work Order #: 13285565

FPL calls your attention to the fact that there may be energized, high voltage electric lines, both overhead and underground, located in the area of this project. It is imperative that you visually survey the area and that you also take the necessary steps to identify all overhead and underground facilities prior to commencing construction to determine whether the construction of any proposed improvements will bring any person, tool, machinery, equipment or object closer to FPL's power lines than the OSHA-prescribed limits. If it will, you must either re-design your project to allow it to be built safely given the pre-existing power line location, or make arrangements with FPL to either deenergize and ground our facilities, or relocate them, possibly at your expense. **You must do this before allowing any construction near the power lines.** It is impossible for FPL to know or predict whether or not the contractors or subcontractors, and their employees, will operate or use cranes, digging apparatus or other mobile equipment, or handle materials or tools, in dangerous proximity to such power lines during the course of construction, and, if so, when and where. Therefore, if it becomes necessary for any contractor or subcontractor, or their employees, to operate or handle cranes, digging apparatus, draglines, mobile equipment, or any other equipment, tools or materials in such a manner that they might come closer to underground or overhead power lines than is permitted by local, state or federal regulations, you and any such contractor or subcontractor must notify FPL in writing of such planned operation prior to the commencement thereof and make all necessary arrangements with FPL in order to carry out the work in a safe manner. **Any work in the vicinity of the electric lines should be suspended until these arrangements are finalized and implemented.**

The National Electrical Safety Code ("NEC") prescribes minimum clearances that must be maintained. If you build your structure so that those clearances cannot be maintained, you may be required to compensate FPL for the relocation of our facilities to comply with those clearances. As such, you should contact FPL prior to commencing construction near pre-existing underground or overhead power lines to make sure that your proposed improvement does not impinge upon the NEC clearances.

It is your responsibility and the responsibility of your contractors and subcontractors on this project to diligently fulfill the following obligations:

1. Make absolutely certain that all persons responsible for operating or handling cranes, digging apparatus, draglines, mobile equipment or any equipment, tool, or material capable of contacting a power line, are in compliance with all applicable state and federal regulations, including but not limited to U.S. Department of Labor OSHA Regulations, while performing their work.
2. Make sure that all cranes, digging apparatus, draglines, mobile equipment, and all other equipment or materials capable of contacting a power line have attached to them any warning signs required by U.S. Department of Labor OSHA Regulations.
3. Post and maintain proper warning signs and advise all employees, new and old alike, of their obligation to keep themselves, their tools, materials and equipment away from power lines per the following OSHA minimum approach distances (refer to OSHA regulations for restrictions):

*Power Line Voltages	Personnel and Equipment		Cranes and Derricks		Travel under or near Power Lines (on construction sites, no load)	
	(29 CFR 1910.333 and 1926.600)	(29 CFR 1926.1407, 1408)	(29 CFR 1926.600 – Equipment)	(1926.1411 – Cranes and Derricks)		
0 - 750 volts	10 Feet**	10 Feet	4 Feet	4 Feet		
751 - 50,000 volts	10 Feet	10 Feet	4 Feet	6 Feet		
69,000 volts	11 Feet	15 Feet	10 Feet	10 Feet		
115,000 volts	13 Feet	15 Feet	10 Feet	10 Feet		
138,000 volts	13 Feet	15 Feet	10 Feet	10 Feet		
230,000 volts	16 Feet	20 Feet	10 Feet	10 Feet		
500,000 volts	25 Feet	25 Feet	16 Feet	16 Feet		

***When uncertain of the voltage, maintain a distance of 20 feet for voltages up to 350,000 volts and 50 feet for voltages greater than 350,000 volts.**
****For personnel approaching insulated secondary conductors less than 750 volts, avoid contact (Maintain 10 Feet to bare energized conductors less than 750 volts).**

4. All excavators are required to contact the Sunshine State One Call of Florida, phone number 1-800-432-4770 or 811 a minimum of two working days (excluding weekends) in advance of commencement of excavation to ensure facilities are located accurately.
5. Conduct all locations and excavations in accordance with the Florida Statute 556 of the Underground Facilities Damage Prevention & Safety Act and all local city and county ordinances that may apply.
6. When an excavation is to take place within a tolerance zone, an excavator shall use increased caution to protect underground facilities. The protection requires hand digging, pot holing, soft digging, vacuum methods, or similar procedures to identify underground facilities.

A copy of this notification must be provided by you to each contractor and subcontractor on this project, to be shared with their supervision and employees prior to commencing work on this project.

E-MAIL TO NICK McKENNA

Means by which this notification was provided to customer and/or contractor

Signed by:
 FPL Representative Signature
 EEAFF51DA3F10477...
 Customer/Developer/Contractor Representative Signature

Nmckenna@greenpointellc.com

Address
9-13-24

Date
2025-01-30

Date



TRANSFORMER PAD LOCATION AND SPECIFICATION

PROJECT: Trailmark Phases 13
ADDRESS: White Rabbit Run

DATE: September 13, 2024
FPL WR#13285565

CUSTOMER AGREES TO:

Provide recorded easement for all FPL facilities on Customer's property. FPL will not start construction until these easements are cleared by the customer of all conflicts preventing construction. Should paving, grass, landscaping or sprinkler systems be installed prior to construction of the underground distribution facilities, the customer will bear the cost of restoring same to their original condition.

Provide location and depth information for all underground facilities and fill or cut to within 6 inches of final grade within the easement. (See attached referenced prints.)

Notify FPL representative two weeks in advance of paving schedule so that FPL can install ducts if required.

Make arrangements for location of FPL pads as shown on location sketch. Provide and install secondary service to padmount transformer. Use a maximum of 8 cables per leg. (See pad detail for entrance space availability for customer service cable) Terminate conduits 3 inches above final grade and provide 7 feet of cable per leg beyond the conduit ends for connection to transformer terminals.

Compact and level 3 inches below final grade an area sufficient for the concrete pad. Provide clear space of 8 feet at the front and 4 feet at sides and rear of the transformer pad to allow for a safe working area.

Keep area above transformer pad clear to allow setting transformer with a crane. If current transformers are required, provide and install 1 1/2 inch rigid conduit from CT's to meter location. Maximum horizontal distance from pad to meter is 10 feet.

Provide a clear space 36 inches in front of meters. If built up meter centers are to be used, provide FPL representative with shop drawings of centers and layout sketch of meter room for FPL approval prior to purchase

FPL AGREES TO:

Provide pad and padmount transformer.
Provide primary ducts and/or cable from FPL facilities to the padmounted transformer.
Provide and install ground rods at the transformer.
Connect customer's service cables to FPL facilities in transformer compartment.
Provide 120/240 volt three phase and single phase service.

REPRESENTING CUSTOMER:

I hereby certify that I am authorized to accept these specifications on behalf of the customer and that I have delivered a copy of these specifications to the customer and all affected contractors.

Signed by:
NAME: Michelle Sutton
EEAF51DA3F10477
(signature)

DATE: 2025-01-30

NAME: Michelle Sutton
(print or type)

TITLE: Chair

TELEPHONE #: 904-940-5850

REPRESENTING FPL:

I hereby certify that I am authorized to accept these specifications on behalf of Florida Power and Light Company.

NAME: 

DATE: 9-13-24



Date _____

Florida Power & Light Company
700 Universe Blvd
Juno Beach, FL 33408
Attention: Daniel Terza

Re: Installation of Underground Electric Distribution Facilities
Project: Trailmark 13
Florida Power & Light Company Work Request #13285565

Dear Daniel:

This is to notify you that the site at the aforementioned project is ready for the installation of your underground electric distribution facilities:

1. The underground cable route has been cleared of trees, stumps and other obstructions.
2. The cable route has been filled or cut to within 6" of final grade.
3. Grade stakes have been set along the cable route marked to indicate final grade.
4. Lot lines and corners have been staked as you requested for reference to locate the cable route.
5. Any grade or reference stakes found missing will be replaced by our surveyors at your request.
6. All flooded areas have been drained.
7. All underground facilities have been staked within 2 feet of their location along the cable route. Stakes are marked with depth, size and type of facility.
8. The above conditions will be maintained throughout construction of FPL facilities.

Signed by:

Michelle Sutton

EEAF61DA3F10477...

Signed for Owner/Developer

Cover Sheet: WR#13285565

Page 1 of 13

INACCESSIBLE 12KV 13KV FUTURE 23KV 23KV FUTURE 25KV 25KV SALT SPRAY ROCK



GENERAL NOTES
 - NOTIFY CUSTOMERS OF TEMPORARY POWER AND TRAFFIC INTERRUPTIONS.
 - PROVIDE WARNING SIGNALS FOR PEDESTRIANS AND TRAFFIC SIGNALS FOR MOTORISTS.
 - SERVICE TO TRAFFIC SIGNAL, SCHOOL FLASHING SIGNAL, AND LIFT STATIONS MUST REMAIN ENERGIZED AT ALL TIMES.

CAUTION
 - THIS DRAWING IS MERELY AN APPROXIMATION. EXACT LOCATION OF FPL COMPANY UNDERGROUND FACILITIES MUST BE DETERMINED PRIOR TO ANY SUBSURFACE OPERATIONS IN THIS AREA.
 - ALL BOUNDARIES ARE APPROXIMATE. ONLY ACCURATE ON THE DAY OF THIS TRANSMISSION. FACILITY LOCATION AND DEPTH SUBJECT TO CHANGE WITHOUT NOTICE. NOT TO BE USED FOR SURVEY OR EXCAVATION PURPOSES.

NOTE: THE LOCATION AND EXISTENCE OF ANY FACILITIES MAY NOT BE RELIED UPON BY THE SUPPLIER IN RESPONDING TO A BID OR IN COMPLYING WITH ANY CONTRACT. SUPPLIER IS RESPONSIBLE FOR EVALUATING SITE CONDITIONS BOTH ABOVE AND BELOW GROUND INCLUDING UNDERGROUND FACILITY LOCATIONS.

**CALL SUNSHINE #811
48 HOURS BEFORE YOU DIG
LOCATE MARKINGS COLOR CODE**

RED	ELECTRIC	BLUE	WATER
YELLOW	GAS-OIL-STEAM	GREEN	SEWER
PINK	TEMP. SURVEY MARKINGS	ORANGE	CABLE TV
WHITE	PROPOSED EXCAVATION		

American Disabilities Act
 If pole placement location does not meet the minimum single point distance of 32" from edge of curb or back of sidewalk, contact your Production Lead, for further instructions.

-STUB, SEAL, AND ELECTRONICALLY MARK ALL EMPTY SERVICE CONDUITS AT THE LOT CORNER FOR FUTURE EXTENSION TO THE METER.



PLEASE BE ADVISED THAT RECEIPT OF THIS DRAWING AND/OR SURVEY, WHICH IS AN APPROXIMATION, DOES NOT RELIEVE YOU OF ANY STATUTORY OBLIGATIONS, INCLUDING THE PROVISIONS CONTAINED IN SECTION 556, FLORIDA STATUTES. CALL 811 (Sunshine811) PRIOR TO ANY EXCAVATION ACTIVITIES

Construction Notes:

- REQUIRED DRAWINGS:**
 13285565_18x24UG
 3S1218900, 3S1218901, 3S924822
- TRENCH:**
 -CENTERLINE OF TRENCH IS 5 FT OUTSIDE R/W
 -MAINTAIN A MINIMUM OF 12" SEPERATON FROM ALL OTHER UTILITIES
 -INSTALL #12C WIRE ALONGSIDE EMPTY COUNDUIT RUNS
 -EXTEND PVC 10FT FROM TX FOR FUTURE SERVICES EASEMENT;
 -10 FEET FRONT
 -CUSTOMER INSTALLED CONDUIT: ALL CABLE:
 - FNC IS 3CC-1000 KCMIL AL 25KV-XLPE IN 1-6" PVC WITH 42" MIN COVER (UNLESS NOTED)
 -3PN3C IS 1CC #1/0A 25KV-XLPE IN 3-2" PVC WITH 36" MIN COVER
 -SECONDARY IS #4/0 TPX HM-HD IN 1-2" PVC WITH 24" MIN COVER (UNLESS NOTED)
 -ALL CABLE AND/OR CONDUIT ENDS ARE TO BE MARKED WITH AN ELECTRONIC MARKER
 -(XXX) DENOTES CABLE PULL DISTANCE
 -UNDERGROUND OBSTRUCTIONS ARE TO BE LOCATED PRIOR TO DIGGING
 -INSTALL NEUTRAL BOND FOR COMMUNICATION COMPANIES AT ALL SINGLE PHASE TRANSFORMERS PER D.C.S. G-11.0.0
 -ALL HANDHOLES ARE 24" (UNLESS NOTED)
 -ALL TRANSFORMERS ARE LOW STYLE (UNLESS NOTED)
 STREET LIGHTS: WR#13297573
 -STREET LIGHTS ARE 6000L, 3000K GE TRADITIONAL ON 13 FT BLACK FIBERGLASS POLES - FPL OWNED AND MAINTAINED

LARGEST A/C TONS:	4.0
HOME SQ. FT.	2,400
Job Owner:	Daniel Terza
Designator:	Juan Compiz
Date:	09/12/2024
Original Size:	18 x 24
Dwg No.:	13285565_18x24 UG.xml
Map:	GD1087

Easement? <input checked="" type="checkbox"/>	Tree Work? <input type="checkbox"/>	Tree Access? <input type="checkbox"/>	Tree Staking Req'd? <input type="checkbox"/>
Designer/Stake? <input type="checkbox"/>	CT/Special Mt? <input type="checkbox"/>	Work with SMO? <input type="checkbox"/>	Survey/Stake? <input type="checkbox"/>
POLE LINE FT:	POLE LINE FT. ON TRANS. POLES:	TRENCH FT:	DUCT BANK FT:
PERMIT REQ'D	CITY <input type="checkbox"/>	COUNTY RD <input type="checkbox"/>	COUNTY AIR <input type="checkbox"/>
WMD <input type="checkbox"/>	RR XING <input type="checkbox"/>	DR. DIST. <input type="checkbox"/>	STATE RD <input type="checkbox"/>
			FAA <input type="checkbox"/>
			TRANS. <input type="checkbox"/>
Requested Tel. Co. Set Poles? <input type="checkbox"/>	Requested Tel. Co. Transfer? <input type="checkbox"/>	Request CATV Transfer? <input type="checkbox"/>	

4			
3			
2	08/26/2024	INSTALL FEEDER CBL FACILITIES TO PROVIDE SERVICE TO 197 LOTS TRAILMARK PH-13	
1	08/26/2024	INSTALL UG FACILITIES TO PROVIDE SERVICE TO 197 LOTS TRAILMARK PH-13	
IPC	DATE	REVISION	

DocuSign Envelope ID: E75F241F-07A5-4356-BE01-B7D288E48777

PLOT DATE/TIME: 09/12/2024 10:57:33 PRINTED BY: cph04k Size: 18 x 24



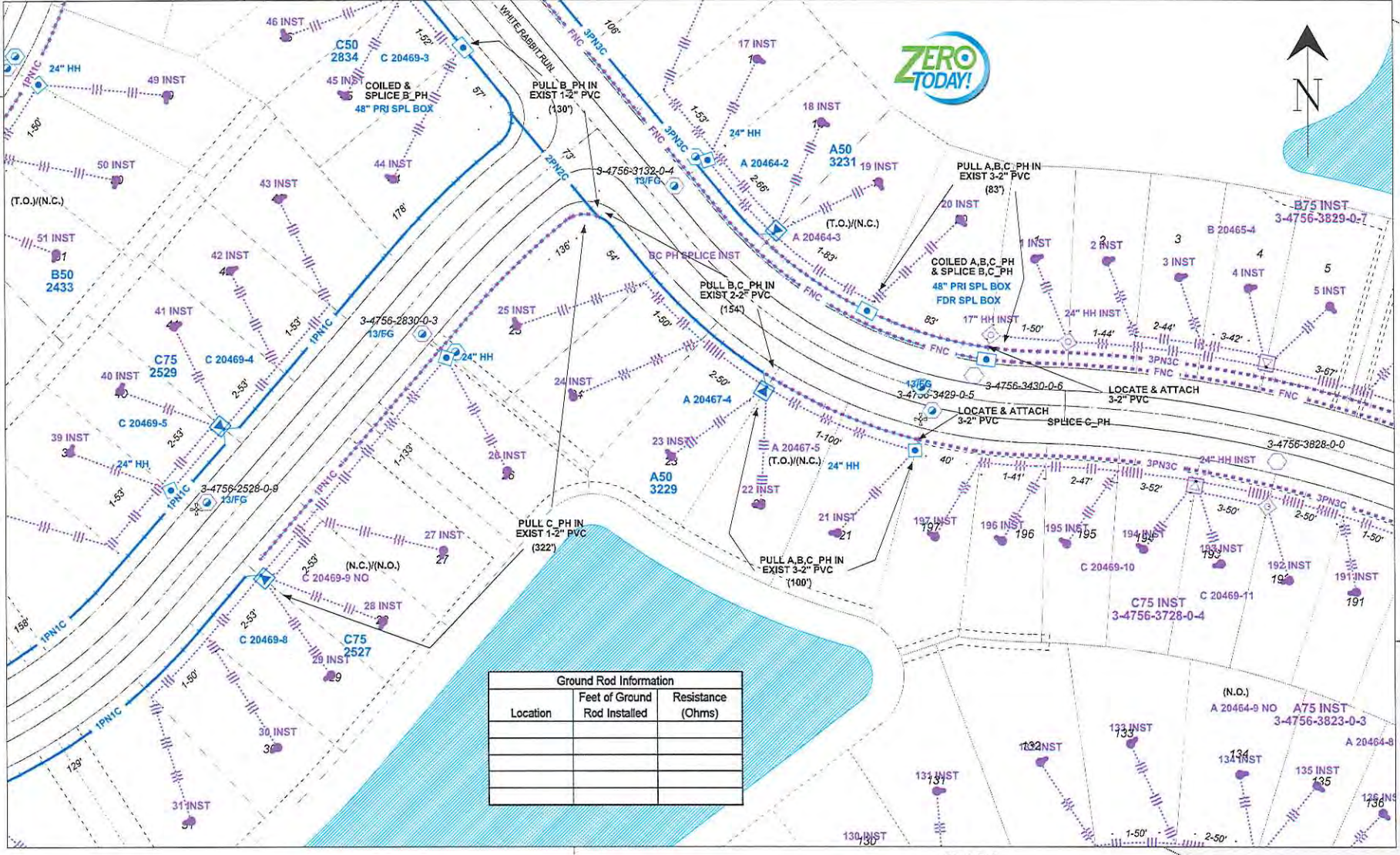

Ground Rod Information		
Location	Feet of Ground Rod Installed	Resistance (Ohms)

4		AS-BUILT CREW PRINT	Job CERTIFIED COMPLETED as shown on this AS-BUILT print. Material changes shown on ROS.	Encasement? [X]	Tree Work? []	Tree Access? []	Tree Staking Req'd? []		Job Owner: Daniel Tarza	M/A: NF	Township: 07 Range: 28 Section 38					
3		Foreman's Signature	Supervisor's Signature	Designer/Stake? []	CT/Special Mtr? []	Work with SMO? []	Survey/Stake? []		Designer: Juan Comptz	TRAILMARK PHASE 13						
2	08/29/2024	INSTALL FEEDER CBL FACILITIES TO PROVIDE SERVICE TO 107 LOTS TRAILMARK PH-13		POLE LINE FT: []	POLE LINE FT. ON TRANMS. POLES: []	TRENCH FT: []	DUCT BANK FT: []		Date: 09/12/2024							
1	09/26/2024	INSTALL LIG FACILITIES TO PROVIDE SERVICE TO 197 LOTS TRAILMARK PH-13	All required ground rods have been shown & verified to be within FPL standards. Values are shown at all locations.	PERMIT CITY []	COUNTY RD []	COUNTY AIR []	STATE RD []	FAA []		Original Size: 18 x 24	TRAILMARK DR. ST AUGUSTINE, FL					
IPC	DATE	REVISION	Invoice	Cert. Date	Foreman's Signature	Date	Requested Tol. Co. Set Polos? []	Requested Tel. Co. Transfer? []	Request CATV Transfer? []	0'	40'	80'	Dwg No: 13285565_18x24 UG.rml	Map: GD1087	WR: 13285565	Page 2 of 13

DocuSign Envelope ID: E75F241F-07A5-4356-BE01-B7D288E48777

Scale: 18 x 24

PRINTED BY: dphq

PLOT DATE/TIME: 09/12/2024 10:51:39

FEEDERS: ORANGEDALE 01864

INACCESSIBLE 13KV FUTURE 23KV 23KV SALT SPRAY ROCK

PAGE 5



Ground Rod Information		
Location	Feet of Ground Rod Installed	Resistance (Ohms)

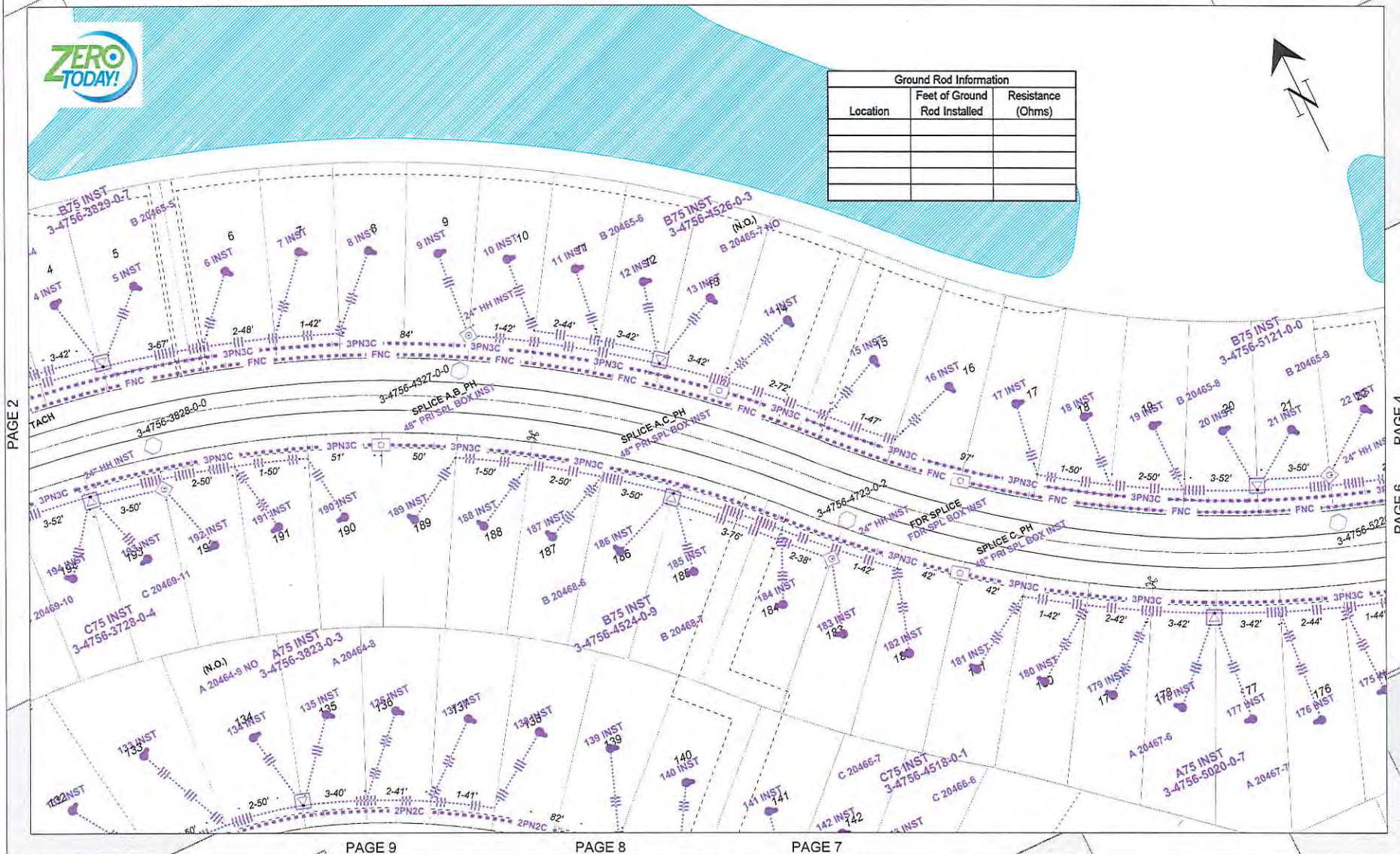

PAGE 2

PAGE 6

PAGE 9

PAGE 8

PAGE 7

PLOT DATE/TIME: 09/12/2024 10:57:43
 PRINTED BY: dpo04
 Scale: 1/4" = 24'

4		AS-BUILT CREW PRINT	Job CERTIFIED COMPLETED as shown on this AS-BUILT print. Material changes shown on ROS.	Assessment? <input checked="" type="checkbox"/>	Tree Work? <input type="checkbox"/>	Tree Access? <input type="checkbox"/>	Tree Staking Req'd? <input type="checkbox"/>
3	08/26/2024	Foreman's Signature	Submaster's Signature	Designer/Stake? <input type="checkbox"/>	CT/Special Mt? <input type="checkbox"/>	Work with SM07? <input type="checkbox"/>	Survey/Stake? <input type="checkbox"/>
2	08/26/2024	AS-BUILT COPY	All required ground rods have been driven & verified to be within FPL standards. Values are shown at all locations.	POLE LINE FT: []	POLE LINE FT. ON TRANSM. POLES: []	TRENCH FT: []	DUCT BANK FT: []
1	08/26/2024	Initials	Foreman's Signature	PERMIT CITY []	COUNTY RD []	COUNTY AIR []	STATE RD []
IPC	DATE	REVISION		REQ'D WMD []	RR XING []	DR. DIST. []	TRANS. []
				Requested Tel. Co. Set Pole? <input type="checkbox"/>	Requested Tel. Co. Transfer? <input type="checkbox"/>	Request CATV Transfer? <input type="checkbox"/>	



Job Owner:	Daniel Tarza	M/A: NF	Township: 07 Range: 28 Section 38
Designer:	Juan Complitz	TRAILMARK PHASE_13	
Date:	09/12/2024		
Original Size:	18 x 24	TRAILMARK DR, ST AUGUSTINE, FL	
Dwg No.	13285565_18x24 UG.xml	Map:	GD1087
WR:	13285565	Page 3 of 13	

DocuSign Envelope ID: E75F241F-07A5-4356-BE01-B7D288E48777

FEEDERS: GATOR 08362, ORANGEDALE 01864

[] INACCESSIBLE [] 13KV [] FUTURE 23KV [X] 23KV [] SALT SPRAY [] ROCK



Ground Rod Information		
Location	Feet of Ground Rod Installed	Resistance (Ohms)

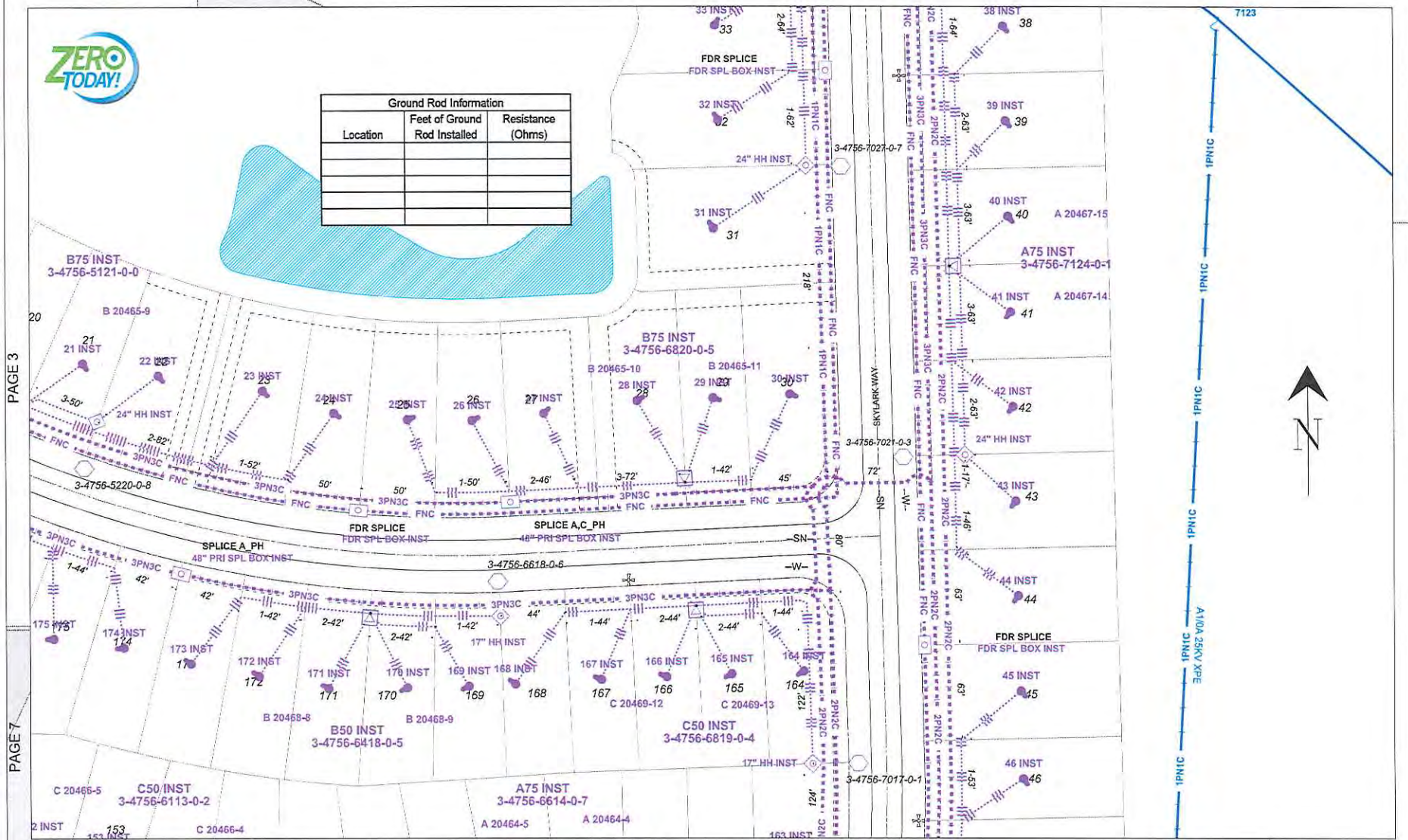

E:\08_18_24
 PRINTED BY: djpbk
 PLOT DATE/TIME: 06/12/2024 10:57:47
 IPC

4	3	2	1
DATE	REVISION	DATE	REVISION
08/26/2024	INSTALL FEEDER CBL FACILITIES TO PROVIDE SERVICE TO 197 LOTS TRAILMARK PH-13	08/26/2024	INSTALL UG FACILITIES TO PROVIDE SERVICE TO 197 LOTS TRAILMARK PH-13

AS-BUILT CREW PRINT		Job CERTIFIED COMPLETED as shown on this AS-BUILT print. Material changes shown on ROS.	
Foreman's Signature	Date	Supervisor's Signature	Date
AS-BUILT COPY		All required ground rods have been drawn & verified to be within PG standards. Values are shown at all locations.	
Initialed	Cert. Date	Foreman's Signature	Date

Easement? [X] Designer/Stake? [] POLE LINE FT: [] PERMIT REQ'D [] WMD [] Requested Tol. Co. Set Poles? []	Tree Work? [] CT/Special MV? [] POLE LINE FT. ON TRANS. POLES: [] COUNTY RD [] COUNTY AIR [] STATE RD [] RR XING [] DR. DIST. [] Requested Tol. Co. Transfer? []	Tree Access? [] Survey/Stake? [] TRENCH FT: [] STATE [] DR. DIST. [] Requested Tol. Co. Transfer? []	Tree Staking Req'd? [] DUCT BANK FT: [] STATE [] DR. DIST. [] Request CATV Transfer? []
---	---	---	--



Job Owner:	Daniel Terza	M/A: NF	Township: 07 Range: 28 Section: 05
Designer:	Juan Comeliz	TRAILMARK PHASE_13	
Date:	09/12/2024	Original Size: 18 x 24	
Dwg No: 13285565_18x24 UG.rvt		TRAILMARK DR. ST AUGUSTINE, FL	
WR: 13285565		Map: G01087	
Page 4 of 13		Page 4 of 13	

DocuSign Envelope ID: E75F241F-07A5-4356-BE01-B7D288E48777

FEEDERS: GATOR 08362, ORANGEDALE 01864

INACCESSIBLE 13KV FUTURE 23KV 23KV SALT SPRAY ROCK

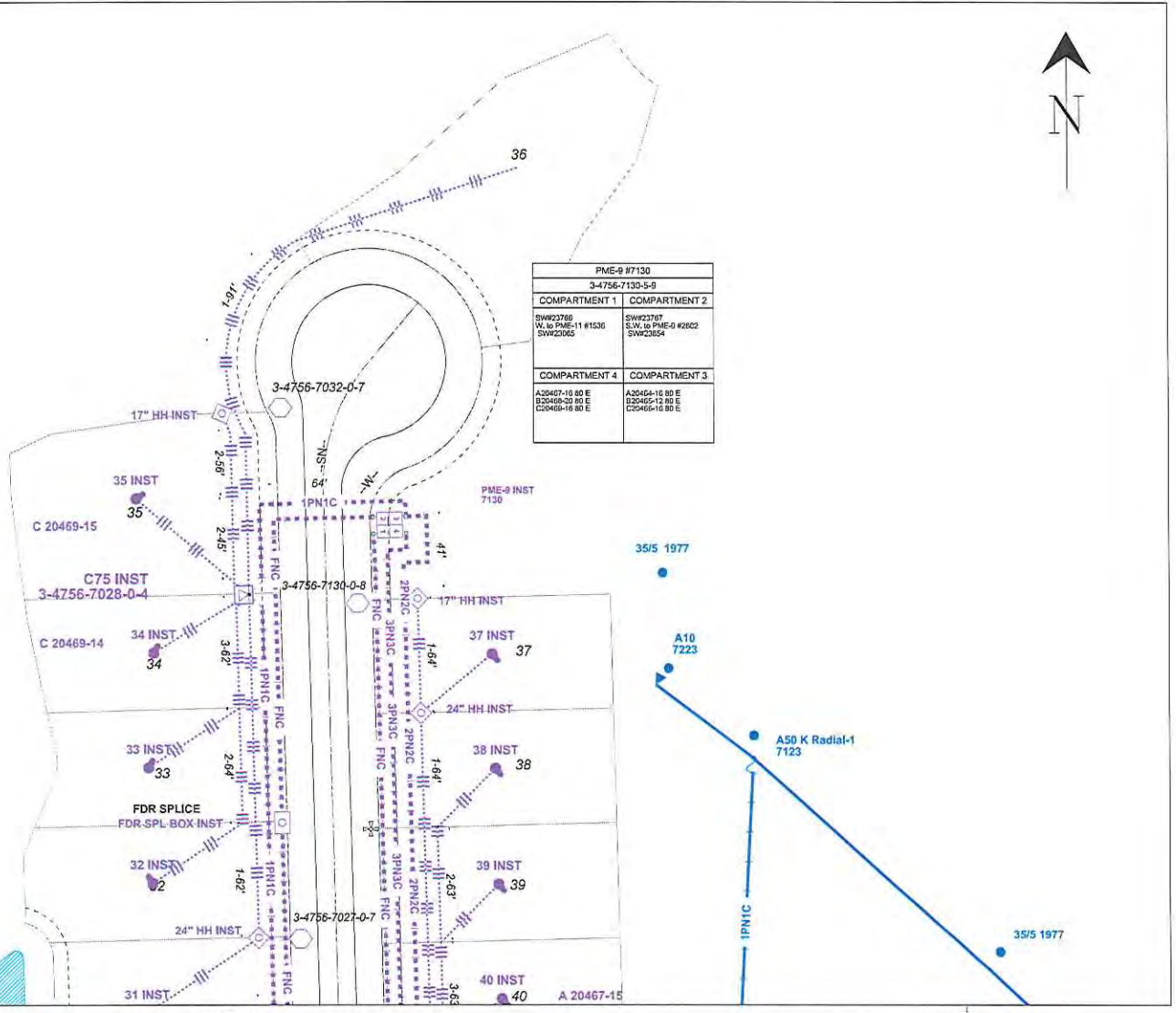

PME-9 #7130	
3-4756-7130-5-9	
COMPARTMENT 1	COMPARTMENT 2
SW#23769 W. to PME-11 #1130 SW#23065	SW#23767 S.W. to PME-9 #2602 SW#23854
COMPARTMENT 4	COMPARTMENT 3
A20467-16 80 E B20468-20 80 E C20469-18 80 E	A20464-16 80 E B20465-12 80 E C20466-18 80 E

Location	Feet of Ground Rod Installed	Resistance (Ohms)

PAGE 4

PAGE 3
 Size: 18 x 24
 PRINTED BY: dpc514
 PLOT DATE/TIME: 09/12/2024 10:57:50

4		AS-BUILT CREW PRINT	Job CERTIFIED COMPLETED as shown on this AS-BUILT print. Material changes shown on ROS.	Easement? <input checked="" type="checkbox"/>	Tree Work? <input type="checkbox"/>	Tree Access? <input type="checkbox"/>	Tree Staking Req'd? <input type="checkbox"/>		Job Owner: Daniel Terza	M/A: NF	Township: 07 Range: 28 Section: 05	
3		Foreman's Signature: _____ Date: _____	Supervisor's Signature: _____ Date: _____	Design/Strike? <input type="checkbox"/>	CT/Special Mt? <input type="checkbox"/>	Work with SMO? <input type="checkbox"/>	Survey/Strike? <input type="checkbox"/>		Designer: Juan Compez	TRAILMARK PHASE_13		
2	08/28/2024	INSTALL FEEDER CBL. FACILITIES TO PROVIDE SERVICE TO 107 LOTS TRAILMARK PH-13	All required ground rods have been driven & verified to the within 1% standards. Values are shown at all locations.	PERMIT REQD	CITY []	COUNTY RD []	COUNTY AIR []	STATE RD []	FAA []	Date: 08/12/2024	Original Size: 18 x 24	TRAILMARK DR, ST AUGUSTINE, FL
1	08/28/2024	INSTALL LUG FACILITIES TO PROVIDE SERVICE TO 107 LOTS TRAILMARK PH-13		AS-BUILT COPY	Request Tol. Co. Set Poles? <input type="checkbox"/>	Request Tol. Co. Transf. []	Request CATV Transfer? <input type="checkbox"/>	Request CATV Transfer? <input type="checkbox"/>	Request CATV Transfer? <input type="checkbox"/>	Request CATV Transfer? <input type="checkbox"/>	Dwg No: 13285565_1b24 UG.xml	Map: G01087
IPC	DATE	REVISION	Initials	Cert. Date	Foreman's Signature	Date	Foreman's Signature	Date	Request CATV Transfer? <input type="checkbox"/>	0' 40' 80'	WR: 13285565	Page 5 of 13

DocuSign Envelope ID: E75F241F-07A5-4356-BE01-B7D288E48777

FEEDERS: GATOR 08362, ORANGEDALE 01864 INACCESSIBLE 13KV FUTURE 23KV 23KV SALT SPRAY ROCK

PAGE 3

PAGE 4

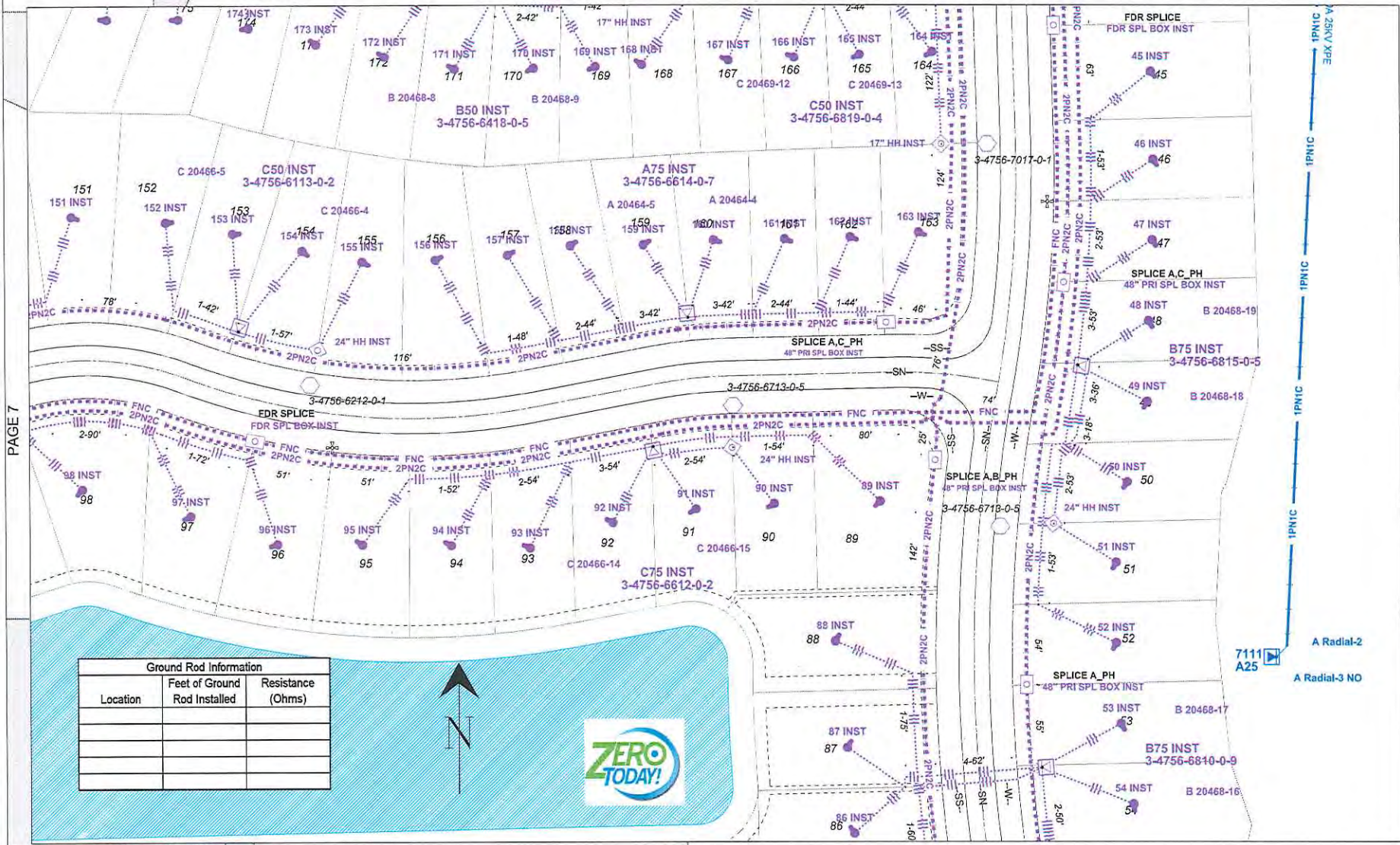

PAGE 7

PAGE 11

PAGE 10

Ground Rod Information		
Location	Feet of Ground Rod Installed	Resistance (Ohms)



PLOT DATE/TIME: 09/12/2024 10:57:53 PRINTED BY: dpr04g Scale: 1/8" = 24'

4	AS-BUILT CREW PRINT	Job CERTIFIED COMPLETED as shown on this AS-BUILT print. Material changes shown on RDS.	Essement? <input checked="" type="checkbox"/>	Tree Work? <input type="checkbox"/>	Tree Access? <input type="checkbox"/>	Tree Staking Rec'd? <input type="checkbox"/>	
	Foreman's Signature _____ Date _____	Supervisor's Signature _____ Date _____	Designer/Stake? <input type="checkbox"/>	CT/Special Mir? <input type="checkbox"/>	Work with SMO? <input type="checkbox"/>	Survey/Stake? <input type="checkbox"/>	
3	AS-BUILT COPY	All required ground rods have been drawn & verified to be within PL standards. Values are shown at all locations.	POLE LINE FT:	POLE LINE FT. ON TRANSM. POLES:	TRENCH FT:	DUCT BANK FT:	
2	08/26/2024	INSTALL FEEDER CBL FACILITIES TO PROVIDE SERVICE TO 197 LOTS TRAILMARK PH-13	PERMIT CITY []	COUNTY RD []	COUNTY AIR []	STATE RD []	FAA []
1	08/26/2024	INSTALL LIG FACILITIES TO PROVIDE SERVICE TO 197 LOTS TRAILMARK PH-13	REQ'D WMD []	RR XING []	DR. DIST. []	TRANS. []	
IPC	DATE	REVISION	Requested Tel. Co. Set Poles? <input type="checkbox"/>	Requested Tel. Co. Transfer? <input type="checkbox"/>	Request CATV Transfer? <input type="checkbox"/>		



Job Owner:	Daniel Terza	M/A:	NF	Township:	07 Rango: 28 Section 05
Designer:	Juan Comptz	TRAILMARK PHASE_13			
Date:	09/12/2024				
Original Size:	18 x 24	TRAILMARK DR, ST AUGUSTINE, FL			
Dwg No:	13285565_18x24 UG.rml	Map:	GD1087		
WR:	13285565	Page 6 of 13			

FEEDERS: ORANGDALE 01864

[] INACCESSIBLE [] 13KV [] FUTURE 23KV [X] 23KV [] SALT SPRAY [] ROCK

PAGE 8

PAGE 3

PAGE 4

PAGE 6

PAGE 10

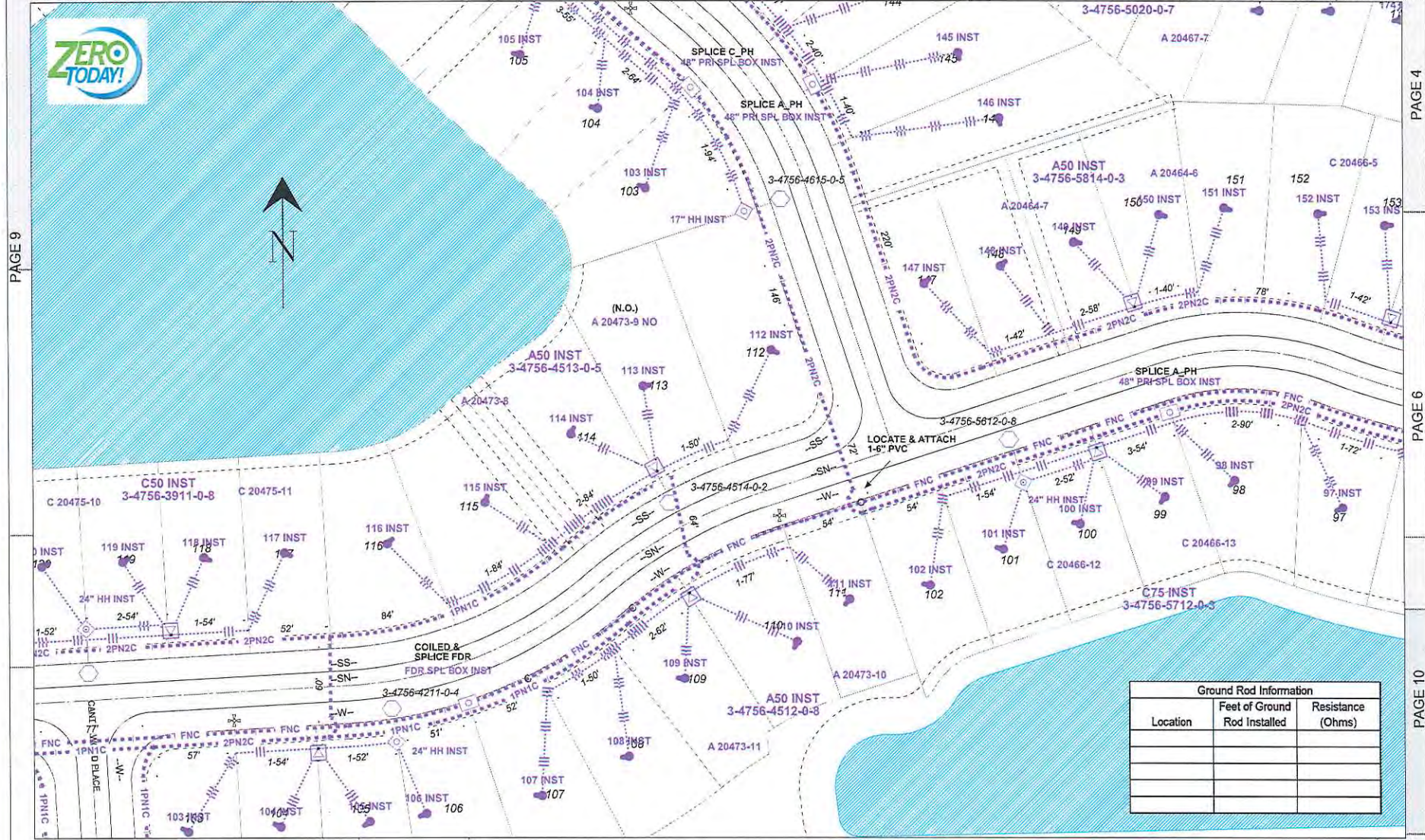

PAGE 9

PAGE 12

PAGE 11

Ground Rod Information		
Location	Feet of Ground Rod Installed	Resistance (Ohms)

4		
3		
2	08/26/2024	INSTALL FEEDER CBL FACILITIES TO PROVIDE SERVICE TO 197 LOTS TRAILMARK PH-13
1	08/26/2024	INSTALL LIG FACILITIES TO PROVIDE SERVICE TO 197 LOTS TRAILMARK PH-13
IPC	DATE	REVISION

AS-BUILT CREW PRINT		Job CERTIFIED COMPLETED as shown on the AS-BUILT print. Material changes shown on ROS.	
Foreman's Signature	Date	Submitter's Signature	Date
AS-BUILT COPY		All required ground rods have been shown & verified to be within 6PL standards. Values are shown at all locations.	
Initials	Cat. Date	Foreman's Signature	Date

Easement? [X] Tree Work? [] Tree Access? [] Tree Staking Req'd? []
 Designer/Stake? [] CT/Special MH? [] Work with SMO? [] Survey/Stake? []
 POLE LINE FT: POLE LINE FT. ON TRANSM. POLES: TRENCH FT: DUCT BANK FT:
 PERMIT CITY [] COUNTY RD [] COUNTY AIR [] STATE RD [] FAX []
 REQ'D WMD [] RR XING [] DR. DIST. [] TRANSM. []
 Requested Tel. Co. Set Poles? [] Requested Tel. Co. Transfer? [] Request CATV Transfer? []



Job Owner:	Daniel Terza	M/A: NF	Township: 07 Range: 28 Section 38
Designer:	Juan Comptz	TRAILMARK PHASE_13	
Date:	09/12/2024		
Original Size:	16 x 24	TRAILMARK DR, ST AUGUSTINE, FL	
0'	40'	80'	Dwg No. 13285565_18x24 UG.mxd Map: G01087
WR: 13285565			Page 7 of 13

DocuSign Envelope ID: E75F241F-07A5-4356-BE01-B7D288E48777

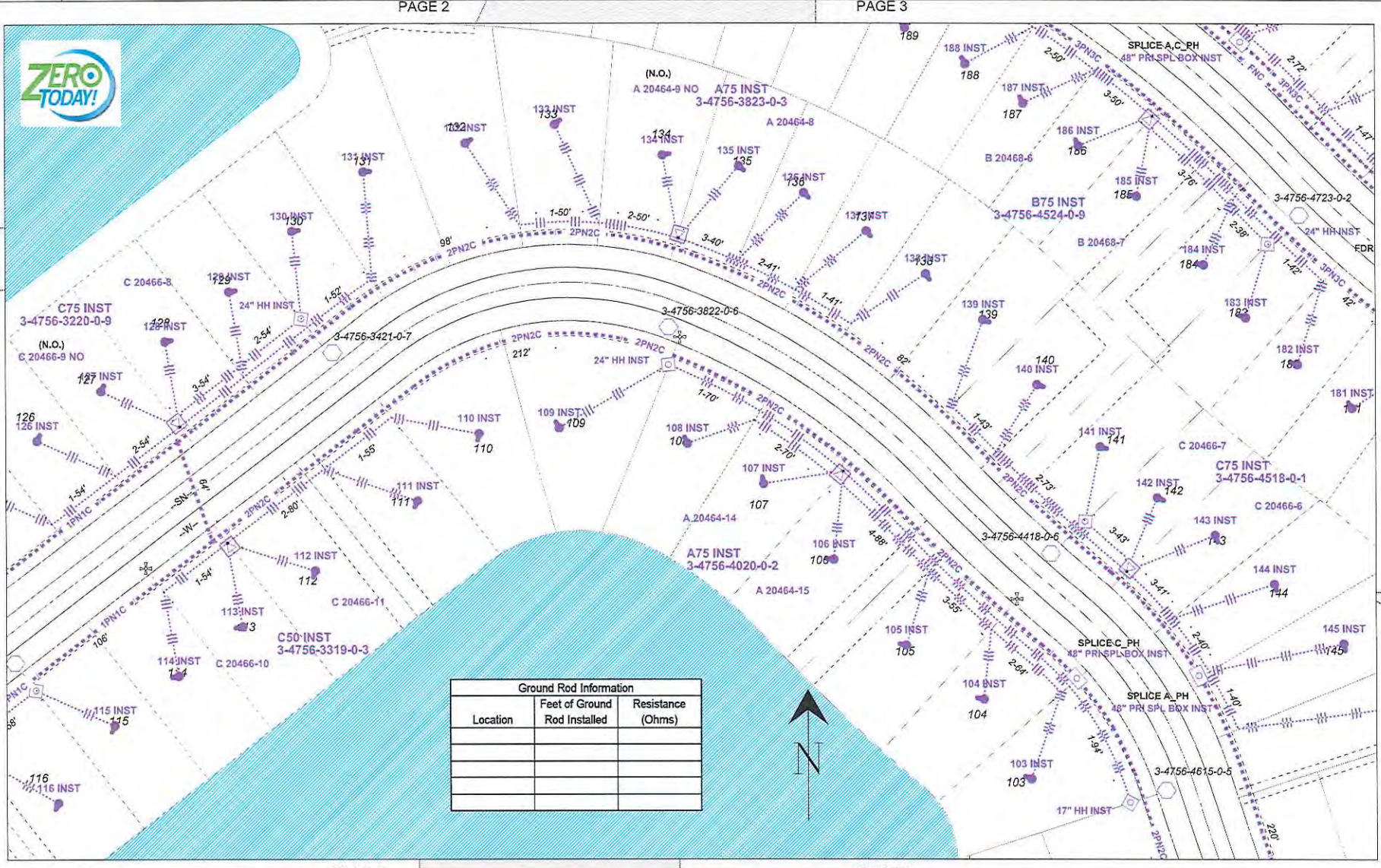

Ground Rod Information		
Location	Feet of Ground Rod Installed	Resistance (Ohms)



<p>PLT DATE/TIME: 09/12/2024 10:58:00</p> <p>IPC DATE DATE REVISION</p>	4	AS-BUILT CREW PRINT	Job CERTIFIED COMPLETED as shown on this AS-BUILT print. Material changes shown on ROS.	Essement? <input checked="" type="checkbox"/>	Tree Work? <input type="checkbox"/>	Tree Access? <input type="checkbox"/>	Tree Staking Req'd? <input type="checkbox"/>		Job Owner: Daniel Terza	M/A: NF	Township: 07 Range: 28 Section 38		
	3	08/26/2024	INSTALL FEEDER CBL FACILITIES TO PROVIDE SERVICE TO 197 LOTS TRAILMARK PH-13	Designer/Stake? <input type="checkbox"/>	CT/Special Mt? <input type="checkbox"/>	Work with SMD? <input type="checkbox"/>	Survey/Stake? <input type="checkbox"/>		Designer: Juan Complit	TRAILMARK PHASE_13			
	2	08/26/2024	INSTALL LUG FACILITIES TO PROVIDE SERVICE TO 187 LOTS TRAILMARK PH-13	All required ground rods have been drawn & verified to be within FPL standards. Values are shown at all locations.	PERMIT CITY <input type="checkbox"/>	COUNTY RD <input type="checkbox"/>	COUNTY AIR <input type="checkbox"/>		STATE RD <input type="checkbox"/>	Date: 09/12/2024	Original Size: 18 x 24 TRAILMARK DR, ST AUGUSTINE, FL		
	1	08/26/2024	INSTALL LUG FACILITIES TO PROVIDE SERVICE TO 187 LOTS TRAILMARK PH-13	Foreman's Signature _____ Date _____	PERMIT REQ'D WMD <input type="checkbox"/>	RR XING <input type="checkbox"/>	DR. DIST. <input type="checkbox"/>		TRANS.M. <input type="checkbox"/>	Request CATV Transfer? <input type="checkbox"/>	Dwg No: 13285565_18x24 UG.xml	Map: CD1087	Page 8 of 13

DocuSign Envelope ID: E75F241F-07A5-4356-BE01-B7D288E48777

FEEDERS: ORANGEDALE 01864

INACCESSIBLE 13KV FUTURE 23KV 23KV SALT SPRAY ROCK

PAGE 8

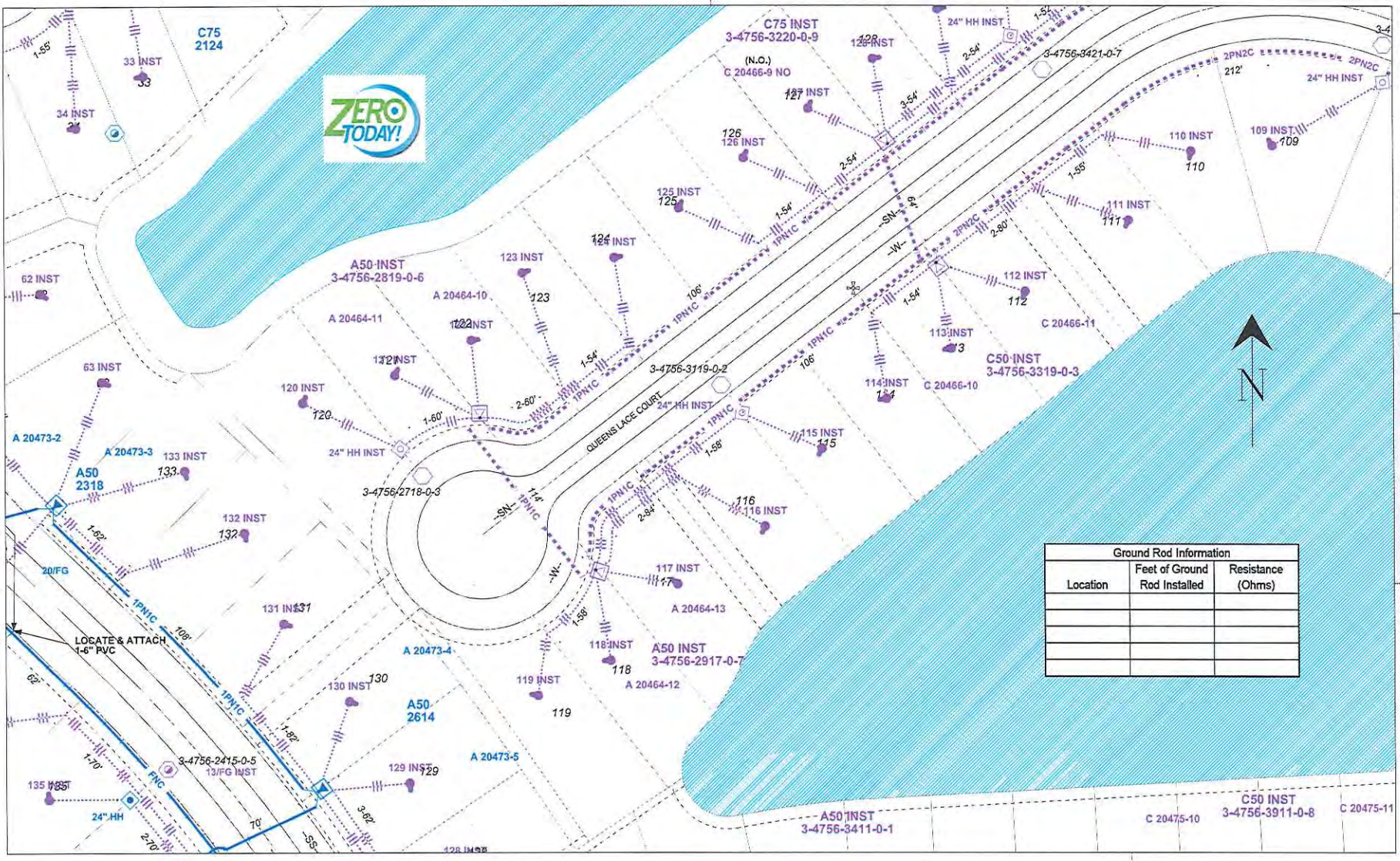

Ground Rod Information		
Location	Feet of Ground Rod Installed	Resistance (Ohms)

Scale: 1/8" = 24'
PRINTED BY: dph04
PLOT DATE/TIME: 09/12/2024 10:58:03

PAGE 3

PAGE 7

IPC	DATE	REVISION
4		
3		
2	08/26/2024	INSTALL FEEDER CBL FACILITIES TO PROVIDE SERVICE TO 197 LOTS TRAILMARK PH-13
1	08/26/2024	INSTALL LG FACILITIES TO PROVIDE SERVICE TO 197 LOTS TRAILMARK PH-13

AS-BUILT CREW PRINT

Job CERTIFIED COMPLETED as shown on this AS-BUILT print. Material charges shown on ROS.

Foreman's Signature: _____ Date: _____

Supervisor's Signature: _____ Date: _____

AS-BUILT COPY

All required ground rods have been driven & verified to be within PG standards. Values are shown at all locations.

Foreman's Signature: _____ Date: _____

Easement? Tree Work? Tree Access? Tree Staking Req'd?
 Designer/Staker? CT/Special MV? Work with SMO? Survey/Stake?
 POLE LINE FT: _____ POLE LINE FT. ON TRANSM. POLES: _____ TRENCH FT: _____ DUCT BANK FT: _____
 PERMIT CITY COUNTY RD COUNTY AIR STATE RD FAA
 REQ'D WMD RR XING DR. DIST. TRANSM.
 Requested Tel. Co. Set Poles? Requested Tel. Co. Transfer? Request CATV Transfer?



Job Owner: Daniel Terza M/A: NF Township: 07 Range: 28 Section 38

Designer: Juan Comptz TRAILMARK PHASE_13

Date: 09/12/2024

Original Size: 18 x 24 TRAILMARK DR, ST AUGUSTINE, FL

0' 40' 80' Dwg No. 13285585_18x24 UC.dwg Map: CD1087

WR: 13285585 Page 9 of 13

DocuSign Envelope ID: E75F241F-07A5-4356-BE01-B7D288E48777

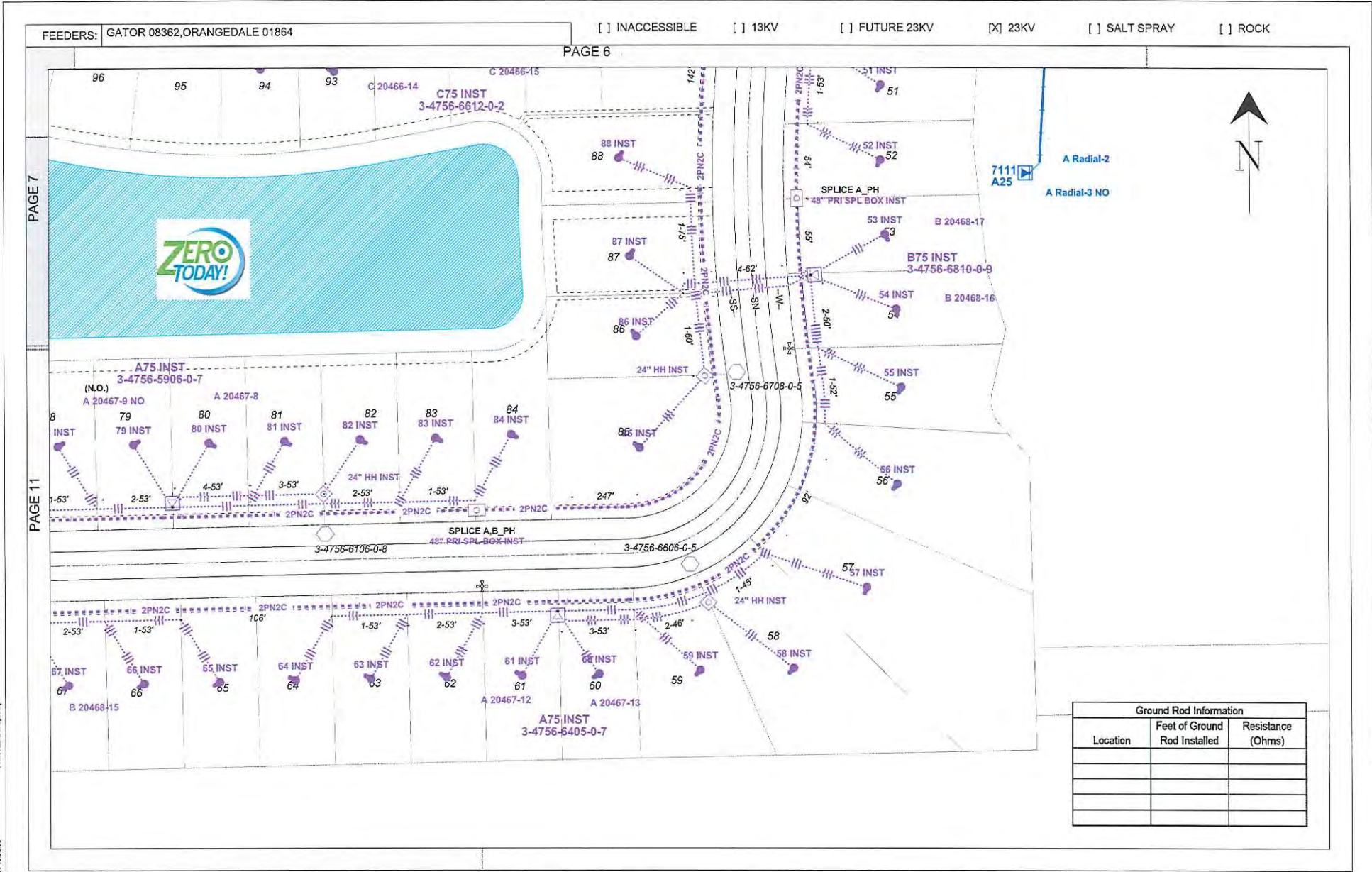

Location	Feet of Ground Rod Installed	Resistance (Ohms)

4		AS-BUILT CREW PRINT	Job CERTIFIED COMPLETED as shown on this AS-BUILT print. Material changes shown on ROS.	Edgeman? <input checked="" type="checkbox"/> []	Tree Work? <input type="checkbox"/> []	Tree Access? <input type="checkbox"/> []	Tree Staking Req'd? <input type="checkbox"/> []	
3		Forman's Signature _____ Date _____	Supervisor's Signature _____ Date _____	Designer/Stake? <input type="checkbox"/> []	CT/Special Mtg? <input type="checkbox"/> []	Work with SMD? <input type="checkbox"/> []	Survey/Stake? <input type="checkbox"/> []	
2	08/26/2024	INSTALL FEEDER CBL FACILITIES TO PROVIDE SERVICE TO 197 LOTS TRAILMARK PH-13		POLE LINE FT:	POLE LINE FT, ON TRANSM. POLES:	TRENCH FT:	DUCT BANK FT:	
1	08/26/2024	INSTALL LUG FACILITIES TO PROVIDE SERVICE TO 197 LOTS TRAILMARK PH-13	All required ground rods have been driven & verified to be within FPL standards. Values are shown at all locations.	PERMIT REQ'D	CITY []	COUNTY AIR []	STATE RD []	FAA []
IPC	DATE	REVISION	Initials	Date	WMD []	RR XING []	DR. DIST. []	TRANSM. []
					Requested Tel. Co. Set Poles? []	Requested Tel. Co. Transfer? []	Request CATV Transfer? []	



Job Owner:	Daniel Tarza	M/A:	NF	Township:	07 Range: 28 Section: 05
Designer:	Juan Compliz	TRAILMARK PHASE_13			
Date:	09/12/2024				
Original Size:	18 x 24	TRAILMARK DR, ST AUGUSTINE, FL			
Dwg No.:	13285565_18x24 UG.rvt	Map: CD1087			
		WR:	13285565	Page 10 of 13	

FEEDERS: ORANGEDALE 01864

INACCESSIBLE 13KV FUTURE 23KV 23KV SALT SPRAY ROCK

PAGE 7

PAGE 6

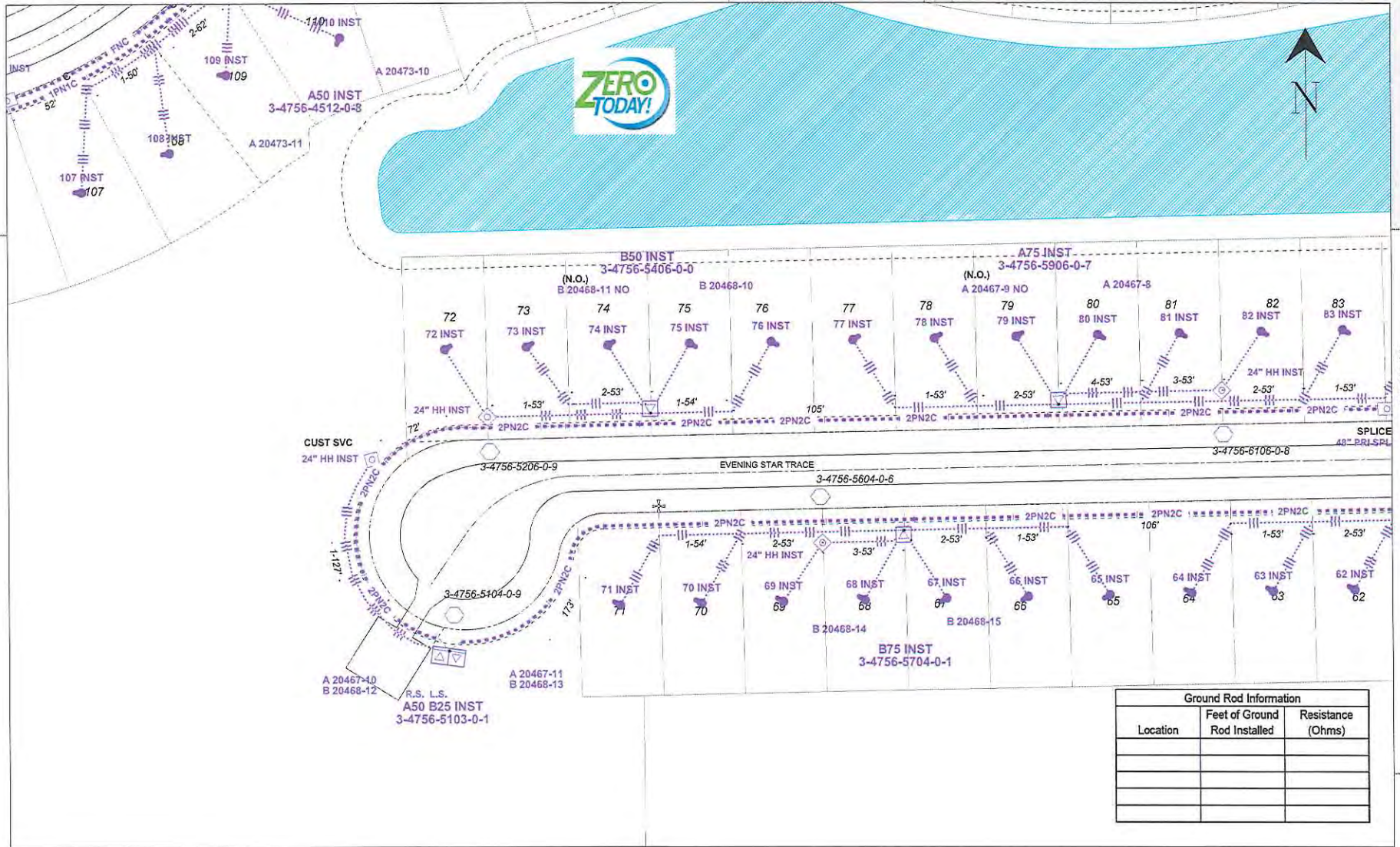

PAGE 10

Ground Rod Information		
Location	Feet of Ground Rod Installed	Resistance (Ohms)

DocuSign Envelope ID: E75F241F-07A5-4356-BE01-B7D288E48777

Scale: 1/8" = 24'

PRINTED BY: gpcnkr

PLOT DATE/TIME: 09/12/2024 10:59:08

4		AS-BUILT CREW PRINT	Job CERTIFIED COMPLETED as shown on this AS-BUILT print. Material changes shown on ROS.	Easement? <input checked="" type="checkbox"/>	Tree Work? <input type="checkbox"/>	Tree Access? <input type="checkbox"/>	Tree Staking Req'd? <input type="checkbox"/>		
3		Foreman's Signature _____ Date _____	Supervisor's Signature _____ Date _____	Designer/Stake? <input type="checkbox"/>	CT/Special Mr? <input type="checkbox"/>	Work with SHD? <input type="checkbox"/>	Survey/Stake? <input type="checkbox"/>		
2	08/26/2024	INSTALL FEEDER CAB. FACILITIES TO PROVIDE SERVICE TO 197 LOTS TRAILMARK PH-13		POLE LINE FT: _____	POLE LINE FT. ON TRANSM. POLES: _____	TRENCH FT: _____	DUCT BANK FT: _____		
1	08/26/2024	INSTALL LG FACILITIES TO PROVIDE SERVICE TO 187 LOTS TRAILMARK PH-13	All required ground rods have been shown & verified to be within FPL boundaries. Values are shown at all locations.	PERMIT REQ'D _____	CITY [] _____	COUNTY RD [] _____	COUNTY AIR [] _____	STATE RD [] _____	FAA [] _____
IPC	DATE	REVISION	Initials _____ Cert. Date _____	Foreman's Signature _____ Date _____	WMD [] _____	RR XING [] _____	DR. DIST. [] _____	TRANSM. [] _____	
					Requested Tol. Co. Set Poles? <input type="checkbox"/>	Requested Tol. Co. Transfer? <input type="checkbox"/>	Request CATV Transfer? <input type="checkbox"/>		



Job Owner:	Daniel Terzu	M/A: NF	Township: 07 Range: 28 Section 05
Designer:	Juan Compliz	TRAILMARK PHASE_13	
Date:	08/12/2024		
Original Size:	18 x 24	TRAILMARK DR. ST AUGUSTINE, FL	
Dwg No.:	13285585_18x24 US.xml	Map: CO1067	
WR:	13285585	Page 11 of 13	

4.

**AGREEMENT BETWEEN SIX MILE CREEK COMMUNITY DEVELOPMENT
DISTRICT AND FLORIDA WATERWAYS, INC. FOR THE PROVISION OF AQUATIC
MAINTENANCE SERVICES
(REVERIE)**

This Agreement (the “Agreement”) is made and entered into as of the 10th day of January, 2025, by and between:

Six Mile Creek Community Development District, a local unit of special-purpose government established pursuant to Chapter 190, *Florida Statutes*, located in St. Johns County, Florida and whose mailing address is 475 West Town Place, Suite 114, St. Augustine, Florida 32092 (the “District”); and

Florida Waterways, Inc., a Florida profit corporation, whose address is 6900 Philips Highway #23 Jacksonville, FL 32216 (the “Contractor”).

RECITALS

WHEREAS, the District was established to plan, construct, install, acquire, finance, manage, and operate public improvements and community facilities pursuant to Chapter 190, *Florida Statutes*.; and

WHEREAS, the District has a need to retain an independent contractor to provide aquatic maintenance services for six (6) ponds located within the boundaries of the District and as set forth on the map attached hereto as **Exhibit B**; and

WHEREAS, the Contractor submitted a proposal and represents that it is qualified to serve as an aquatic maintenance contractor and provide such services to the District.

NOW THEREFORE, in consideration of the recitals, agreements, and mutual covenants contained herein, and other good and valuable consideration, the receipt and sufficiency of which are hereby acknowledged by the parties, the parties agree as follows:

SECTION 1. RECITALS. The recitals so stated are true and correct and by this reference are incorporated into and form a material part of this Agreement.

SECTION 2. MANNER OF CONTRACTOR’S PERFORMANCE.

- A.** The Contractor shall provide the specific aquatic maintenance services as shown in **Exhibit A**, attached and incorporated herein (the “Services”) within the six (6) ponds within the District as identified in **Exhibit B**, attached and incorporated herein.
- B.** Contractor shall be solely responsible for the means, manner and methods by which its duties, obligations and responsibilities are met to the satisfaction of the District and in accordance with this Agreement. Contractor shall use industry best practices and procedures when carrying out the Services including the Florida Friendly green

industry standards of the Florida Department of Environmental Protection. Any additional compensation for additional services shall be paid only as negotiated between the parties and upon the written authorization of the District.

1. At no time shall the Contractor utilize any products, compounds, or materials that contain copper in any form in any of the water bodies within the project area unless such products, compounds, or materials are specifically approved for usage in water bodies by both the U.S. Environmental Protection Agency and the State of Florida. Usage of such products, compounds, or materials must also be in compliance with applicable St. Johns River Water Management District (“SJRWMD”) rules and any and all SJRWMD permits issued for the stormwater system within the District.
 2. Contractor shall ensure that employees who work with registered and restricted-use herbicides are certified as to qualifications for handling and applying material safely and correctly in accordance with the Florida Pesticide Law administered by the Florida Department of Agriculture and Consumer Services. Due to the presence of wetlands, such employees shall possess a Florida Aquatic Pesticide License and other applicable certifications. The Contractor shall also be familiar with the Fish and Wildlife Conservation Commission’s Chapter 68F-20: Aquatic Plant Management Permits. Prior to the utilization of herbicides on site, the Contractor will furnish to the District, copies of all required licenses and applicable permits for treatment and/or removal of aquatic plants in waters of the State. The Contractor shall at all times abide by each herbicide label.
- C. This Agreement grants to Contractor the right to enter the lands that are subject to this Agreement, for those purposes described in this Agreement, and Contractor hereby agrees to comply with all applicable laws, rules, ordinances and regulations affecting the provision of the Services.
- D. The Contractor shall report directly to the District’s Designee who shall be the District Manager. Contractor shall use all due care to protect the property of the District, its residents and landowners from damage and shall follow and be responsible for the Services set forth in **Exhibit A**. Contractor agrees to repair any damage resulting from Contractor’s activities and work within twenty-four (24) hours.

SECTION 3. COMPENSATION; TERM.

- A. As compensation for the Services described in this Agreement and **Exhibit A**, the District shall pay Contractor an amount not to exceed One Thousand One Hundred Fifty Dollars (\$1,150.00) per month, which amount includes all tools, labor, and materials necessary to complete the Services, for an annual amount not-to-exceed Thirteen Thousand Eight Hundred Dollars (\$13,800.00). The term of this Agreement shall be from February 10, 2025, through September 30, 2025, and shall automatically renew unless terminated earlier in accordance with the terms of this Agreement.

- A. If the District should desire additional work or services not provided in **Exhibit A**, the Contractor agrees to negotiate in good faith to undertake such additional work or services. Upon successful negotiations, the parties shall agree in writing to a work order, addendum, addenda, or change order to this Agreement as set forth in Section 4 herein.
- B. The District may require, as a condition precedent to making any payment to the Contractor that all subcontractors, material men, suppliers or laborers be paid and require evidence, in the form of Lien Releases or partial Waivers of Lien, to be submitted to the District by those subcontractors, material men, suppliers or laborers, and further require that the Contractor provide an Affidavit relating to the payment of said indebtedness. Further, the District shall have the right to require, as a condition precedent to making any payment, evidence from the Contractor, in a form satisfactory to the District, that any indebtedness of the Contractor, as to services to the District, has been paid and that the Contractor has met all of the obligations with regard to the withholding and payment of taxes, Social Security payments, Workmen's Compensation, Unemployment Compensation contributions, and similar payroll deductions from the wages of employees.
- C. The Contractor shall maintain records conforming to usual accounting practices. Further, the Contractor agrees to render an invoice to the District, in writing, which shall be delivered or mailed to the District by the fifth (5th) day of the next succeeding month. This invoice is due and payable within forty-five (45) days of receipt by the District, or in accordance with Florida's Prompt Payment Act, whichever is sooner. The invoice shall include such supporting information as the District may reasonably require the Contractor to provide.

SECTION 4. CHANGE ORDERS. Contractor understands that the Services may be reduced, enlarged or otherwise modified in scope. If any additional Services are proposed beyond those identified in this Agreement, Contractor shall perform them but only after receiving a written change order from the District. Contractor shall cooperate with and assist the District in preparing and determining the scope of any change order. In the event the service represents a unit price set forth in this Agreement, Contractor's compensation shall be adjusted for the added or deducted services proposed by the change order in accordance with the unit prices established in the Agreement. In the event the service is not represented by a lump sum or unit price set forth in this Agreement, Contractor's compensation shall be adjusted for the added or deducted services proposed by the change order as reasonably determined by the District in conference with the Contractor.

SECTION 5. INSURANCE. Contractor shall, at its own expense, maintain insurance during the performance of the Services under this Agreement, with limits of liability not less than the following:

Workers Compensation	statutory
General Liability	

<i>Bodily Injury (including contractual)</i>	\$1,000,000
<i>Property Damage (including contractual)</i>	\$1,000,000
Automobile Liability (if applicable)	
<i>Bodily Injury and Property Damage</i>	\$1,000,000
Pollution Liability	\$1,000,000
Herbicide/Pesticide Applicators Coverage	\$1,000,000

Contractor shall provide the District with a certificate naming the District, its officers, agents and employees as an additional insured. At no time shall Contractor be without insurance in the above amounts. No policy may be canceled during the term of this Agreement without at least thirty (30) days written notice to the District. An insurance certificate evidencing compliance with this section shall be sent to the District prior to the commencement of any performance under this Agreement.

SECTION 6. INDEPENDENT CONTRACTOR. It is understood and agreed that at all times the relationship of Contractor and its employees, agents, subcontractors or anyone directly or indirectly employed by Contractor to the District is the relationship of an independent contractor and not that of an employee, agent, joint venturer or partner of the District. Nothing in this Agreement shall be interpreted or construed as creating or establishing the relationship of employer and employee between the District and Contractor or any of its employees, agents, subcontractors or anyone directly or indirectly employed by Contractor. The parties acknowledge that Contractor is not an employee for state or federal tax purposes. Contractor shall hire and pay all of Contractor’s employees, agents, subcontractors or anyone directly or indirectly employed by Contractor, all of whom shall be employees of Contractor and not employees of District and at all times entirely under Contractor’s supervision, direction and control.

In particular, District will not: i) Withhold FICA (Social Security) from Contractor’s payments; ii) Make state or federal unemployment insurance contributions on Contractor’s behalf; iii) Withhold state or federal income tax from payment to Contractor; iv) Make disability insurance contributions on behalf of Contractor; or v) Obtain workers’ compensation insurance on behalf of Contractor.

SECTION 7. COMPLIANCE WITH LAWS, ORDINANCES AND REGULATIONS. The Contractor shall keep, observe, and perform all requirements of applicable local, State, and Federal laws, rules, regulations, or ordinances. If the Contractor fails to notify the District in writing within five (5) days of the receipt of any notice, order, required to comply notice, or a report of a violation or an alleged violation, made by any local, State, or Federal governmental body or agency or subdivision thereof with respect to the services being rendered under this Agreement or any action of the Contractor or any of its agents, servants, employees, or materialmen, or with respect to terms, wages, hours, conditions of employment, safety appliances, or any other requirements applicable to provision of services, or fails to comply with any requirement of such agency within five (5) days after receipt of any such notice, order, request to comply notice, or report of a violation or an alleged violation, the District may terminate this Agreement, such termination to be effective upon the giving of notice of termination.

SECTION 8. DEFAULT AND PROTECTION AGAINST THIRD PARTY INTERFERENCE. A default by either party under this Agreement shall entitle the other to all remedies available at law or in equity, which may include, but not be limited to, the right of actual damages and/or specific performance. The District shall be solely responsible for enforcing its rights under this Agreement against any interfering third party. Nothing contained in this Agreement shall limit or impair the District's right to protect its rights from interference by a third party to this Agreement.

SECTION 9. ENFORCEMENT OF AGREEMENT. In the event that either party is required to enforce this Agreement by court proceedings or otherwise, then the parties agree that the substantially prevailing party shall be entitled to recover from the other all fees and costs incurred, including reasonable attorney's fees, paralegal fees, expert witness fees and costs for trial, alternative dispute resolution, or appellate proceedings.

SECTION 10. AMENDMENTS. Amendments to and waivers of the provisions contained in this Agreement may be made only by an instrument in writing which is executed by both the District and the Contractor.

SECTION 11. AUTHORIZATION. The execution of this Agreement has been duly authorized by the appropriate body or official of the District and the Contractor, both the District and the Contractor have complied with all the requirements of law, and both the District and the Contractor have full power and authority to comply with the terms and provisions of this instrument.

SECTION 12. NOTICES. All notices, requests, consents and other communications under this Agreement ("Notices") shall be in writing and shall be delivered, mailed by First Class Mail, postage prepaid, or overnight delivery service, to the parties, as follows:

A. If to District: Six Mile Creek Community Development District
475 West Town Place, Suite 114
St. Augustine, Florida 32092
Attn: District Manager

With a copy to: Kutak Rock LLP
107 West College Avenue
Tallahassee, Florida 32301
Attn: District Counsel

B. If to Contractor: Florida Waterways, Inc.
3832-010 Baymeadows Road
PMB 379
Jacksonville, Fl 32217
Attn: Jim Schwartz

Except as otherwise provided in this Agreement, any Notice shall be deemed received only upon actual delivery at the address set forth above. Notices delivered after 5:00 p.m. (at the place

of delivery) or on a non-business day, shall be deemed received on the next business day. If any time for giving Notice contained in this Agreement would otherwise expire on a non-business day, the Notice period shall be extended to the next succeeding business day. Saturdays, Sundays, and legal holidays recognized by the United States government shall not be regarded as business days. Counsel for the District and counsel for the Contractor may deliver Notice on behalf of the District and the Contractor. Any party or other person to whom Notices are to be sent or copied may notify the other parties and addressees of any change in name or address to which Notices shall be sent by providing the same on five (5) days written notice to the parties and addressees set forth herein.

SECTION 13. ARM'S LENGTH TRANSACTION. This Agreement has been negotiated fully between the District and the Contractor as an arm's length transaction. Both parties participated fully in the preparation of this Agreement and received the advice of counsel. In the case of a dispute concerning the interpretation of any provision of this Agreement, both parties are deemed to have drafted, chosen, and selected the language, and the doubtful language will not be interpreted or construed against either the District or the Contractor.

SECTION 14. THIRD PARTY BENEFICIARIES. This Agreement is solely for the benefit of the District and the Contractor and no right or cause of action shall accrue upon or by reason, to or for the benefit of any third party not a formal party to this Agreement. Nothing in this Agreement expressed or implied is intended or shall be construed to confer upon any person or corporation other than the District and the Contractor any right, remedy, or claim under or by reason of this Agreement or any of the provisions or conditions of this Agreement; and all of the provisions, representations, covenants, and conditions contained in this Agreement shall inure to the sole benefit of and shall be binding upon the District and the Contractor and their respective representatives, successors, and assigns.

SECTION 15. ASSIGNMENT. Neither the District nor the Contractor may assign this Agreement or any monies to become due hereunder without the prior written approval of the other.

SECTION 16. APPLICABLE LAW AND VENUE. This Agreement and the provisions contained herein shall be construed, interpreted and controlled according to the laws of the State of Florida. Venue shall be in St. Johns County, Florida.

SECTION 17. INDEMNIFICATION.

- A.** Contractor, its employees, agents and subcontractors shall defend, hold harmless and indemnify the District and its supervisors, officers, staff, employees, representatives and agents against any claims, damages, liabilities, losses and costs, including, but not limited to, reasonable attorneys' fees, to the extent caused by the acts or omissions of Contractor, and other persons employed or utilized by Contractor in the performance of this Agreement or the Services performed hereunder.
- B.** Obligations under this section shall include the payment of all settlements, judgments, damages, liquidated damages, penalties, forfeitures, back pay awards, court costs, arbitration and/or mediation costs, litigation expenses, attorney fees, paralegal fees and expert witness fees (incurred in court, out of court, on appeal, or in bankruptcy)

proceedings) as ordered.

SECTION 18. LIMITATIONS ON GOVERNMENTAL LIABILITY. Nothing in this Agreement shall be deemed as a waiver of immunity or limits of liability of the District beyond any statutory limited waiver of immunity or limits of liability in Section 768.28, *Florida Statutes*, or other statute, and nothing in this Agreement shall inure to the benefit of any third party for the purpose of allowing any claim which would otherwise be barred under the Doctrine of Sovereign Immunity or by operation of law.

SECTION 19. TERMINATION. The District agrees that the Contractor may terminate this Agreement for cause by providing thirty (30) days written notice of termination to the District; provided, however, that the District shall be provided a reasonable opportunity to cure any failure under this Agreement. The Contractor agrees that the District may terminate this Agreement immediately for cause by providing written notice of termination to the Contractor. The District shall provide thirty (30) days written notice of termination without cause. Upon any termination of this Agreement, the Contractor shall be entitled to payment for all Services rendered up until the effective termination of this Agreement, subject to whatever claims or off sets the District may have against the Contractor as the sole means of recovery for termination.

SECTION 20. OWNERSHIP OF DOCUMENTS. All rights in and title to all plans, drawings, specifications, ideas, concepts, designs, sketches, models, programs, software, creation, inventions, reports, or other tangible work product originally developed by Contractor pursuant to this Agreement shall be and remain the sole and exclusive property of the District when developed and shall be considered work for hire.

SECTION 21. COMPLIANCE WITH PUBLIC RECORDS LAWS. Contractor understands and agrees that all documents of any kind provided to the District in connection with this Agreement may be public records, and, accordingly, Contractor agrees to comply with all applicable provisions of Florida law in handling such records, including but not limited to Section 119.0701, *Florida Statutes*. Contractor acknowledges that the designated public records custodian for the District is the District Manager (“Public Records Custodian”). Among other requirements and to the extent applicable by law, the Contractor shall 1) keep and maintain public records required by the District to perform the service; 2) upon request by the Public Records Custodian, provide the District with the requested public records or allow the records to be inspected or copied within a reasonable time period at a cost that does not exceed the cost provided in Chapter 119, *Florida Statutes*; 3) ensure that public records which are exempt or confidential, and exempt from public records disclosure requirements, are not disclosed except as authorized by law for the duration of the contract term and following the contract term if the Contractor does not transfer the records to the Public Records Custodian of the District; and 4) upon completion of the contract, transfer to the District, at no cost, all public records in Contractor’s possession or, alternatively, keep, maintain and meet all applicable requirements for retaining public records pursuant to Florida laws. When such public records are transferred by the Contractor, the Contractor shall destroy any duplicate public records that are exempt or confidential and exempt from public records disclosure requirements. All records stored electronically must be provided to the District in a format that is compatible with Microsoft Word or Adobe PDF formats.

IF THE CONTRACTOR HAS QUESTIONS REGARDING THE APPLICATION OF CHAPTER 119, *FLORIDA STATUTES*, TO THE CONTRACTOR'S DUTY TO PROVIDE PUBLIC RECORDS RELATING TO THIS CONTRACT, CONTACT THE CUSTODIAN OF PUBLIC RECORDS AT 475 WEST TOWN PLACE, SUITE 114, ST. AUGUSTINE, FLORIDA 32092; (904) 940-5850; JOLIVER@GMSNF.COM

SECTION 22. SEVERABILITY. The invalidity or unenforceability of any one or more provisions of this Agreement shall not affect the validity or enforceability of the remaining portions of this Agreement, or any part of this Agreement not held to be invalid or unenforceable.

SECTION 23. E-VERIFY. The Contractor shall comply with and perform all applicable provisions of Section 448.095, *Florida Statutes*. Accordingly, to the extent required by Florida Statute, Contractor shall register with and use the United States Department of Homeland Security's E-Verify system to verify the work authorization status of all newly hired employees. The District may terminate this Agreement immediately for cause if there is a good faith belief that the Contractor has knowingly violated Section 448.091, *Florida Statutes*. By entering into this Agreement, the Contractor represents that no public employer has terminated a contract with the Contractor under Section 448.095(2)(c), *Florida Statutes*, within the year immediately preceding the date of this Agreement.

SECTION 24. COMPLIANCE WITH SECTION 20.055, FLORIDA STATUTES. The Contractor agrees to comply with Section 20.055(5), Florida Statutes, to cooperate with the inspector general in any investigation, audit, inspection, review, or hearing pursuant such section and to incorporate in all subcontracts the obligation to comply with Section 20.055(5), Florida Statutes.

SECTION 25. HEADINGS FOR CONVENIENCE ONLY. The descriptive headings in this Agreement are for convenience only and shall not control nor affect the meaning or construction of any of the provisions of this Agreement.

SECTION 26. ENTIRE AGREEMENT. This instrument shall constitute the final and complete expression of the agreement between the parties relating to the subject matter of this Agreement. To the extent that any of the terms of this Agreement are determined to conflict with any terms included in the attached Proposal, the terms of this Agreement are agreed and deemed to be controlling.

SECTION 27. STATEMENT REGARDING CHAPTER 287 REQUIREMENTS. Contractor acknowledges that, in addition to all Laws and Regulations that apply to this Agreement, the following provisions of Florida law ("Public Integrity Laws") apply to this Agreement:

A. Section 287.133, *Florida Statutes*, titled *Public entity crime; denial or revocation of the right to transact business with public entities*;

- B.** Section 287.134, *Florida Statutes*, titled *Discrimination; denial or revocation of the right to transact business with public entities*;
- C.** Section 287.135, *Florida Statutes*, titled *Prohibition against contracting with scrutinized companies*;
- D.** Section 287.137, *Florida Statutes*, titled *Antitrust violations; denial or revocation of the right to transact business with public entities; denial of economic benefits*; and
- E.** Section 287.138, *Florida Statutes*, titled *Contracting with entities of foreign countries of concern prohibited*.

Contractor acknowledges that the Public Integrity Laws prohibit entities that meet certain criteria from bidding on or entering into or renewing a contract with governmental entities, including with the District (“Prohibited Criteria”).

Contractor acknowledges that the District may terminate this Agreement if the Contractor is found to have met the Prohibited Criteria or violated the Public Integrity Laws.

Contractor certifies that in entering into this Agreement, neither it nor any of its officers, directors, executives, partners, shareholders, employees, members, or agents who are active in the management of the entity, nor any affiliate of the entity, meets any of the Prohibited Criteria, and in the event such status changes, Contractor shall immediately notify the District. By entering into this Agreement, Contractor agrees that any renewal or extension of this Contract shall be deemed a recertification of such status.

[SIGNATURES ON NEXT PAGE]

IN WITNESS WHEREOF, the parties hereto have executed this Agreement on the day and year first written above.

ATTEST:

Signed by:
Daniel Laughlin
Witness

SIX MILE CREEK COMMUNITY DEVELOPMENT DISTRICT

Signed by:
Michelle Sutton
Chair, Board of Supervisors

Melissa Schwartz
Witness

FLORIDA WATERWAYS, INC.

Jim Schwartz
By: Jim Schwartz
Its: President

- Exhibit A:** Proposal/Scope of Services
- Exhibit B:** Map of Ponds

Exhibit A Proposal/Scope of Services

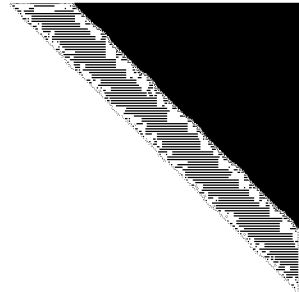

Waterway Management Service Agreement

This Agreement made the date set forth below, by and between Florida Waterways, Inc., a Florida Corporation, hereinafter called "FLORIDA WATERWAYS", and

SIX MILE CREEK CDD - REVERIE
c/o Real Manage
Attn: Alex Boyer, CAM
10301 Deerwood Park Boulevard
Jacksonville, FL 32256

hereinafter called "CUSTOMER". The parties hereto agree as follows:

1. FLORIDA WATERWAYS agrees to manage certain lake(s), pond(s), and/or waterway(s) in accordance with the terms and conditions of this Agreement for a period of **twelve (12) months** from the date of receipt in the following location:

Twelve (12) annual visits for treatment and/or inspection of six (6) approximately 23.00+ acres of wet detention ponds as shown on Waterway Map

2. CUSTOMER agrees to pay FLORIDA WATERWAYS, its agents or assigns, each month the following sum for specified waterway management services:

Algae and Aquatic Vegetation Control (including Floating Vegetation)	\$ <u>1,150.00</u>
Shoreline Grass Control	\$ <u>INCLUDED</u>
Debris Removal	\$ <u>INCLUDED</u>
Management Reporting	\$ <u>INCLUDED</u>
Triploid Grass Carp Stocking w/ Included Permitting Assistance	\$ <u>8.50/fbh</u>
Water Quality & Chemistry Monitoring	\$ <u>INCLUDED</u>
Florida Waterways 100% Control Guarantee	\$ <u>INCLUDED</u>
(Free Callback Service & Additional Treatments, if required)	

Total Recurring Monthly Service Charges **\$ 1,150.00**

*Services performed at FLORIDA WATERWAYS' sole discretion for the success of the Waterway Management Services Agreement.

3. FLORIDA WATERWAYS agrees to commence Waterway Management Services within fifteen (15) business days, weather permitting, from the date of receipt of this executed Agreement plus initial deposit and/or issuance of required government permits.

4. The terms and conditions appearing on the reverse side form an integral part of this Agreement, and CUSTOMER hereby acknowledges that they have read and are familiar with the contents thereof. Agreement must be accepted in its entirety to be considered valid.

By:
FLORIDA WATERWAYS

CUSTOMER

Jim Schwartz
Email: Jim@FloridaLake.com

Printed: _____

Proposal Date: January 6, 2025

Dated: _____

The office containing both copies of this Agreement shall have no further force and effect unless signed and returned by CUSTOMER to FLORIDA WATERWAYS within ninety (90) days from the effective Proposal Date.

Exhibit B Map of Ponds

Waterway Map

Reverse (Six Mile Creek CDD)



5.

**AGREEMENT BETWEEN SIX MILE CREEK COMMUNITY DEVELOPMENT
DISTRICT AND FLORIDA WATERWAYS, INC. FOR THE PROVISION OF AQUATIC
MAINTENANCE SERVICES
(TRAILMARK)**

This Agreement (the “Agreement”) is made and entered into as of the 10th day of January, 2025, by and between:

Six Mile Creek Community Development District, a local unit of special-purpose government established pursuant to Chapter 190, *Florida Statutes*, located in St. Johns County, Florida and whose mailing address is 475 West Town Place, Suite 114, St. Augustine, Florida 32092 (the “District”); and

Florida Waterways, Inc., a Florida profit corporation, whose address is 6900 Philips Highway #23 Jacksonville, FL 32216 (the “Contractor”).

RECITALS

WHEREAS, the District was established to plan, construct, install, acquire, finance, manage, and operate public improvements and community facilities pursuant to Chapter 190, *Florida Statutes*.; and

WHEREAS, the District has a need to retain an independent contractor to provide aquatic maintenance services for thirty-seven (37) ponds located within the boundaries of the District and as set forth on the map attached hereto as **Exhibit B**; and

WHEREAS, the Contractor submitted a proposal and represents that it is qualified to serve as an aquatic maintenance contractor and provide such services to the District.

NOW THEREFORE, in consideration of the recitals, agreements, and mutual covenants contained herein, and other good and valuable consideration, the receipt and sufficiency of which are hereby acknowledged by the parties, the parties agree as follows:

SECTION 1. RECITALS. The recitals so stated are true and correct and by this reference are incorporated into and form a material part of this Agreement.

SECTION 2. MANNER OF CONTRACTOR’S PERFORMANCE.

- A.** The Contractor shall provide the specific aquatic maintenance services as shown in **Exhibit A**, attached and incorporated herein (the “Services”) within the thirty-seven (37) ponds within the District as identified in **Exhibit B**, attached and incorporated herein.
- B.** Contractor shall be solely responsible for the means, manner and methods by which its duties, obligations and responsibilities are met to the satisfaction of the District and in accordance with this Agreement. Contractor shall use industry best practices and

procedures when carrying out the Services including the Florida Friendly green industry standards of the Florida Department of Environmental Protection. Any additional compensation for additional services shall be paid only as negotiated between the parties and upon the written authorization of the District.

1. At no time shall the Contractor utilize any products, compounds, or materials that contain copper in any form in any of the water bodies within the project area unless such products, compounds, or materials are specifically approved for usage in water bodies by both the U.S. Environmental Protection Agency and the State of Florida. Usage of such products, compounds, or materials must also be in compliance with applicable St. Johns River Water Management District (“SJRWMD”) rules and any and all SJRWMD permits issued for the stormwater system within the District.
 2. Contractor shall ensure that employees who work with registered and restricted-use herbicides are certified as to qualifications for handling and applying material safely and correctly in accordance with the Florida Pesticide Law administered by the Florida Department of Agriculture and Consumer Services. Due to the presence of wetlands, such employees shall possess a Florida Aquatic Pesticide License and other applicable certifications. The Contractor shall also be familiar with the Fish and Wildlife Conservation Commission’s Chapter 68F-20: Aquatic Plant Management Permits. Prior to the utilization of herbicides on site, the Contractor will furnish to the District, copies of all required licenses and applicable permits for treatment and/or removal of aquatic plants in waters of the State. The Contractor shall at all times abide by each herbicide label.
- C. This Agreement grants to Contractor the right to enter the lands that are subject to this Agreement, for those purposes described in this Agreement, and Contractor hereby agrees to comply with all applicable laws, rules, ordinances and regulations affecting the provision of the Services.
- D. The Contractor shall report directly to the District’s Designee who shall be the District Manager. Contractor shall use all due care to protect the property of the District, its residents and landowners from damage and shall follow and be responsible for the Services set forth in **Exhibit A**. Contractor agrees to repair any damage resulting from Contractor’s activities and work within twenty-four (24) hours.

SECTION 3. COMPENSATION; TERM.

- A. As compensation for the Services described in this Agreement and **Exhibit A**, the District shall pay Contractor an amount not to exceed Four Thousand One Hundred Forty Five Dollars (\$4,145.00) per month, which amount includes all tools, labor, and materials necessary to complete the Services, for an annual amount not-to-exceed Forty Nine Thousand Seven Hundred Forty Dollars (\$49,740.00). The term of this Agreement shall be from February 10, 2025, through September 30, 2025, and shall

automatically renew unless terminated earlier in accordance with the terms of this Agreement.

- A. If the District should desire additional work or services not provided in **Exhibit A**, the Contractor agrees to negotiate in good faith to undertake such additional work or services. Upon successful negotiations, the parties shall agree in writing to a work order, addendum, addenda, or change order to this Agreement as set forth in Section 4 herein.
- B. The District may require, as a condition precedent to making any payment to the Contractor that all subcontractors, material men, suppliers or laborers be paid and require evidence, in the form of Lien Releases or partial Waivers of Lien, to be submitted to the District by those subcontractors, material men, suppliers or laborers, and further require that the Contractor provide an Affidavit relating to the payment of said indebtedness. Further, the District shall have the right to require, as a condition precedent to making any payment, evidence from the Contractor, in a form satisfactory to the District, that any indebtedness of the Contractor, as to services to the District, has been paid and that the Contractor has met all of the obligations with regard to the withholding and payment of taxes, Social Security payments, Workmen's Compensation, Unemployment Compensation contributions, and similar payroll deductions from the wages of employees.
- C. The Contractor shall maintain records conforming to usual accounting practices. Further, the Contractor agrees to render an invoice to the District, in writing, which shall be delivered or mailed to the District by the fifth (5th) day of the next succeeding month. This invoice is due and payable within forty-five (45) days of receipt by the District, or in accordance with Florida's Prompt Payment Act, whichever is sooner. The invoice shall include such supporting information as the District may reasonably require the Contractor to provide.

SECTION 4. CHANGE ORDERS. Contractor understands that the Services may be reduced, enlarged or otherwise modified in scope. If any additional Services are proposed beyond those identified in this Agreement, Contractor shall perform them but only after receiving a written change order from the District. Contractor shall cooperate with and assist the District in preparing and determining the scope of any change order. In the event the service represents a unit price set forth in this Agreement, Contractor's compensation shall be adjusted for the added or deducted services proposed by the change order in accordance with the unit prices established in the Agreement. In the event the service is not represented by a lump sum or unit price set forth in this Agreement, Contractor's compensation shall be adjusted for the added or deducted services proposed by the change order as reasonably determined by the District in conference with the Contractor.

SECTION 5. INSURANCE. Contractor shall, at its own expense, maintain insurance during the performance of the Services under this Agreement, with limits of liability not less than the following:

Workers Compensation

statutory

General Liability	
<i>Bodily Injury (including contractual)</i>	\$1,000,000
<i>Property Damage (including contractual)</i>	\$1,000,000
Automobile Liability (if applicable)	
<i>Bodily Injury and Property Damage</i>	\$1,000,000
Pollution Liability	\$1,000,000
Herbicide/Pesticide Applicators Coverage	\$1,000,000

Contractor shall provide the District with a certificate naming the District, its officers, agents and employees as an additional insured. At no time shall Contractor be without insurance in the above amounts. No policy may be canceled during the term of this Agreement without at least thirty (30) days written notice to the District. An insurance certificate evidencing compliance with this section shall be sent to the District prior to the commencement of any performance under this Agreement.

SECTION 6. INDEPENDENT CONTRACTOR. It is understood and agreed that at all times the relationship of Contractor and its employees, agents, subcontractors or anyone directly or indirectly employed by Contractor to the District is the relationship of an independent contractor and not that of an employee, agent, joint venturer or partner of the District. Nothing in this Agreement shall be interpreted or construed as creating or establishing the relationship of employer and employee between the District and Contractor or any of its employees, agents, subcontractors or anyone directly or indirectly employed by Contractor. The parties acknowledge that Contractor is not an employee for state or federal tax purposes. Contractor shall hire and pay all of Contractor’s employees, agents, subcontractors or anyone directly or indirectly employed by Contractor, all of whom shall be employees of Contractor and not employees of District and at all times entirely under Contractor’s supervision, direction and control.

In particular, District will not: i) Withhold FICA (Social Security) from Contractor’s payments; ii) Make state or federal unemployment insurance contributions on Contractor’s behalf; iii) Withhold state or federal income tax from payment to Contractor; iv) Make disability insurance contributions on behalf of Contractor; or v) Obtain workers’ compensation insurance on behalf of Contractor.

SECTION 7. COMPLIANCE WITH LAWS, ORDINANCES AND REGULATIONS. The Contractor shall keep, observe, and perform all requirements of applicable local, State, and Federal laws, rules, regulations, or ordinances. If the Contractor fails to notify the District in writing within five (5) days of the receipt of any notice, order, required to comply notice, or a report of a violation or an alleged violation, made by any local, State, or Federal governmental body or agency or subdivision thereof with respect to the services being rendered under this Agreement or any action of the Contractor or any of its agents, servants, employees, or materialmen, or with respect to terms, wages, hours, conditions of employment, safety appliances, or any other requirements applicable to provision of services, or fails to comply with any requirement of such agency within five (5) days after receipt of any such notice, order, request to comply notice, or report of a

violation or an alleged violation, the District may terminate this Agreement, such termination to be effective upon the giving of notice of termination.

SECTION 8. DEFAULT AND PROTECTION AGAINST THIRD PARTY INTERFERENCE. A default by either party under this Agreement shall entitle the other to all remedies available at law or in equity, which may include, but not be limited to, the right of actual damages and/or specific performance. The District shall be solely responsible for enforcing its rights under this Agreement against any interfering third party. Nothing contained in this Agreement shall limit or impair the District's right to protect its rights from interference by a third party to this Agreement.

SECTION 9. ENFORCEMENT OF AGREEMENT. In the event that either party is required to enforce this Agreement by court proceedings or otherwise, then the parties agree that the substantially prevailing party shall be entitled to recover from the other all fees and costs incurred, including reasonable attorney's fees, paralegal fees, expert witness fees and costs for trial, alternative dispute resolution, or appellate proceedings.

SECTION 10. AMENDMENTS. Amendments to and waivers of the provisions contained in this Agreement may be made only by an instrument in writing which is executed by both the District and the Contractor.

SECTION 11. AUTHORIZATION. The execution of this Agreement has been duly authorized by the appropriate body or official of the District and the Contractor, both the District and the Contractor have complied with all the requirements of law, and both the District and the Contractor have full power and authority to comply with the terms and provisions of this instrument.

SECTION 12. NOTICES. All notices, requests, consents and other communications under this Agreement ("Notices") shall be in writing and shall be delivered, mailed by First Class Mail, postage prepaid, or overnight delivery service, to the parties, as follows:

A. If to District: Six Mile Creek Community Development District
475 West Town Place, Suite 114
St. Augustine, Florida 32092
Attn: District Manager

With a copy to: Kutak Rock LLP
107 West College Avenue
Tallahassee, Florida 32301
Attn: District Counsel

B. If to Contractor: Florida Waterways, Inc.
3832-010 Baymeadows Road
PMB 379
Jacksonville, Fl 32217
Attn: Jim Schwartz

Except as otherwise provided in this Agreement, any Notice shall be deemed received only upon actual delivery at the address set forth above. Notices delivered after 5:00 p.m. (at the place of delivery) or on a non-business day, shall be deemed received on the next business day. If any time for giving Notice contained in this Agreement would otherwise expire on a non-business day, the Notice period shall be extended to the next succeeding business day. Saturdays, Sundays, and legal holidays recognized by the United States government shall not be regarded as business days. Counsel for the District and counsel for the Contractor may deliver Notice on behalf of the District and the Contractor. Any party or other person to whom Notices are to be sent or copied may notify the other parties and addressees of any change in name or address to which Notices shall be sent by providing the same on five (5) days written notice to the parties and addressees set forth herein.

SECTION 13. ARM'S LENGTH TRANSACTION. This Agreement has been negotiated fully between the District and the Contractor as an arm's length transaction. Both parties participated fully in the preparation of this Agreement and received the advice of counsel. In the case of a dispute concerning the interpretation of any provision of this Agreement, both parties are deemed to have drafted, chosen, and selected the language, and the doubtful language will not be interpreted or construed against either the District or the Contractor.

SECTION 14. THIRD PARTY BENEFICIARIES. This Agreement is solely for the benefit of the District and the Contractor and no right or cause of action shall accrue upon or by reason, to or for the benefit of any third party not a formal party to this Agreement. Nothing in this Agreement expressed or implied is intended or shall be construed to confer upon any person or corporation other than the District and the Contractor any right, remedy, or claim under or by reason of this Agreement or any of the provisions or conditions of this Agreement; and all of the provisions, representations, covenants, and conditions contained in this Agreement shall inure to the sole benefit of and shall be binding upon the District and the Contractor and their respective representatives, successors, and assigns.

SECTION 15. ASSIGNMENT. Neither the District nor the Contractor may assign this Agreement or any monies to become due hereunder without the prior written approval of the other.

SECTION 16. APPLICABLE LAW AND VENUE. This Agreement and the provisions contained herein shall be construed, interpreted and controlled according to the laws of the State of Florida. Venue shall be in St. Johns County, Florida.

SECTION 17. INDEMNIFICATION.

- A.** Contractor, its employees, agents and subcontractors shall defend, hold harmless and indemnify the District and its supervisors, officers, staff, employees, representatives and agents against any claims, damages, liabilities, losses and costs, including, but not limited to, reasonable attorneys' fees, to the extent caused by the acts or omissions of Contractor, and other persons employed or utilized by Contractor in the performance of this Agreement or the Services performed hereunder.
- B.** Obligations under this section shall include the payment of all settlements, judgments, damages, liquidated damages, penalties, forfeitures, back pay awards, court costs,

arbitration and/or mediation costs, litigation expenses, attorney fees, paralegal fees and expert witness fees (incurred in court, out of court, on appeal, or in bankruptcy proceedings) as ordered.

SECTION 18. LIMITATIONS ON GOVERNMENTAL LIABILITY. Nothing in this Agreement shall be deemed as a waiver of immunity or limits of liability of the District beyond any statutory limited waiver of immunity or limits of liability in Section 768.28, *Florida Statutes*, or other statute, and nothing in this Agreement shall inure to the benefit of any third party for the purpose of allowing any claim which would otherwise be barred under the Doctrine of Sovereign Immunity or by operation of law.

SECTION 19. TERMINATION. The District agrees that the Contractor may terminate this Agreement for cause by providing thirty (30) days written notice of termination to the District; provided, however, that the District shall be provided a reasonable opportunity to cure any failure under this Agreement. The Contractor agrees that the District may terminate this Agreement immediately for cause by providing written notice of termination to the Contractor. The District shall provide thirty (30) days written notice of termination without cause. Upon any termination of this Agreement, the Contractor shall be entitled to payment for all Services rendered up until the effective termination of this Agreement, subject to whatever claims or off sets the District may have against the Contractor as the sole means of recovery for termination.

SECTION 20. OWNERSHIP OF DOCUMENTS. All rights in and title to all plans, drawings, specifications, ideas, concepts, designs, sketches, models, programs, software, creation, inventions, reports, or other tangible work product originally developed by Contractor pursuant to this Agreement shall be and remain the sole and exclusive property of the District when developed and shall be considered work for hire.

SECTION 21. COMPLIANCE WITH PUBLIC RECORDS LAWS. Contractor understands and agrees that all documents of any kind provided to the District in connection with this Agreement may be public records, and, accordingly, Contractor agrees to comply with all applicable provisions of Florida law in handling such records, including but not limited to Section 119.0701, *Florida Statutes*. Contractor acknowledges that the designated public records custodian for the District is the District Manager (“Public Records Custodian”). Among other requirements and to the extent applicable by law, the Contractor shall 1) keep and maintain public records required by the District to perform the service; 2) upon request by the Public Records Custodian, provide the District with the requested public records or allow the records to be inspected or copied within a reasonable time period at a cost that does not exceed the cost provided in Chapter 119, *Florida Statutes*; 3) ensure that public records which are exempt or confidential, and exempt from public records disclosure requirements, are not disclosed except as authorized by law for the duration of the contract term and following the contract term if the Contractor does not transfer the records to the Public Records Custodian of the District; and 4) upon completion of the contract, transfer to the District, at no cost, all public records in Contractor’s possession or, alternatively, keep, maintain and meet all applicable requirements for retaining public records pursuant to Florida laws. When such public records are transferred by the Contractor, the Contractor shall destroy any duplicate public records that are exempt or confidential and exempt from public records disclosure

requirements. All records stored electronically must be provided to the District in a format that is compatible with Microsoft Word or Adobe PDF formats.

IF THE CONTRACTOR HAS QUESTIONS REGARDING THE APPLICATION OF CHAPTER 119, *FLORIDA STATUTES*, TO THE CONTRACTOR'S DUTY TO PROVIDE PUBLIC RECORDS RELATING TO THIS CONTRACT, CONTACT THE CUSTODIAN OF PUBLIC RECORDS AT 475 WEST TOWN PLACE, SUITE 114, ST. AUGUSTINE, FLORIDA 32092; (904) 940-5850; JOLIVER@GMSNF.COM

SECTION 22. SEVERABILITY. The invalidity or unenforceability of any one or more provisions of this Agreement shall not affect the validity or enforceability of the remaining portions of this Agreement, or any part of this Agreement not held to be invalid or unenforceable.

SECTION 23. E-VERIFY. The Contractor shall comply with and perform all applicable provisions of Section 448.095, *Florida Statutes*. Accordingly, to the extent required by Florida Statute, Contractor shall register with and use the United States Department of Homeland Security's E-Verify system to verify the work authorization status of all newly hired employees. The District may terminate this Agreement immediately for cause if there is a good faith belief that the Contractor has knowingly violated Section 448.091, *Florida Statutes*. By entering into this Agreement, the Contractor represents that no public employer has terminated a contract with the Contractor under Section 448.095(2)(c), *Florida Statutes*, within the year immediately preceding the date of this Agreement.

SECTION 24. COMPLIANCE WITH SECTION 20.055, FLORIDA STATUTES. The Contractor agrees to comply with Section 20.055(5), Florida Statutes, to cooperate with the inspector general in any investigation, audit, inspection, review, or hearing pursuant such section and to incorporate in all subcontracts the obligation to comply with Section 20.055(5), Florida Statutes.

SECTION 25. HEADINGS FOR CONVENIENCE ONLY. The descriptive headings in this Agreement are for convenience only and shall not control nor affect the meaning or construction of any of the provisions of this Agreement.

SECTION 26. ENTIRE AGREEMENT. This instrument shall constitute the final and complete expression of the agreement between the parties relating to the subject matter of this Agreement. To the extent that any of the terms of this Agreement are determined to conflict with any terms included in the attached Proposal, the terms of this Agreement are agreed and deemed to be controlling.

SECTION 27. STATEMENT REGARDING CHAPTER 287 REQUIREMENTS. Contractor acknowledges that, in addition to all Laws and Regulations that apply to this Agreement, the following provisions of Florida law ("Public Integrity Laws") apply to this Agreement:

- A.** Section 287.133, *Florida Statutes*, titled *Public entity crime; denial or revocation of the right to transact business with public entities*;
- B.** Section 287.134, *Florida Statutes*, titled *Discrimination; denial or revocation of the right to transact business with public entities*;
- C.** Section 287.135, *Florida Statutes*, titled *Prohibition against contracting with scrutinized companies*;
- D.** Section 287.137, *Florida Statutes*, titled *Antitrust violations; denial or revocation of the right to transact business with public entities; denial of economic benefits*; and
- E.** Section 287.138, *Florida Statutes*, titled *Contracting with entities of foreign countries of concern prohibited*.

Contractor acknowledges that the Public Integrity Laws prohibit entities that meet certain criteria from bidding on or entering into or renewing a contract with governmental entities, including with the District (“Prohibited Criteria”).

Contractor acknowledges that the District may terminate this Agreement if the Contractor is found to have met the Prohibited Criteria or violated the Public Integrity Laws.

Contractor certifies that in entering into this Agreement, neither it nor any of its officers, directors, executives, partners, shareholders, employees, members, or agents who are active in the management of the entity, nor any affiliate of the entity, meets any of the Prohibited Criteria, and in the event such status changes, Contractor shall immediately notify the District. By entering into this Agreement, Contractor agrees that any renewal or extension of this Contract shall be deemed a recertification of such status.

[SIGNATURES ON NEXT PAGE]

IN WITNESS WHEREOF, the parties hereto have executed this Agreement on the day and year first written above.

ATTEST:

Signed by:

Daniel Laughlin

Witness

**SIX MILE CREEK COMMUNITY
DEVELOPMENT DISTRICT**

Signed by:

Michelle Sutton

Chair, Board of Supervisors

FLORIDA WATERWAYS, INC.

Melisse Schwartz

Witness

Jim Schwartz

By: Jim Schwartz
Its: President

- Exhibit A:** Proposal/Scope of Services
- Exhibit B:** Map of Ponds

Exhibit A Proposal/Scope of Services

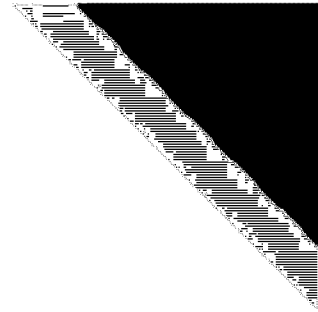

Waterway Management Service Agreement

This Agreement made the date set forth below, by and between Florida Waterways, Inc., a Florida Corporation, hereinafter called "FLORIDA WATERWAYS", and

SIX MILE CREEK CDD
c/o Real Manage
Attn: Alex Boyer, CAM
10301 Deerwood Park Boulevard
Jacksonville, FL 32256

hereinafter called "CUSTOMER". The parties hereto agree as follows:

1. FLORIDA WATERWAYS agrees to manage certain lake(s), pond(s), and/or waterway(s) in accordance with the terms and conditions of this Agreement for a period of **twelve (12) months** from the date of receipt in the following location:

Forty-Eight (48) annual visits for treatment and/or inspection of thirty-seven (37) approximately 68,157 acres of wet detention ponds and a canal as shown on Waterway Map

2. CUSTOMER agrees to pay FLORIDA WATERWAYS, its agents or assigns, each month the following sum for specified waterway management services:

Algae and Aquatic Vegetation Control (including Floating Vegetation)	\$ 4,145.00
Shoreline Grass Control	\$ INCLUDED
Debris Removal	\$ INCLUDED
Management Reporting	\$ INCLUDED
Triphol'd Grass Control Stacking w/ Included Permitting Assistance	\$ 8,500.00
Water Quality & Chemistry Monitoring	\$ INCLUDED
Florida Waterways 100% Control Guarantee	\$ INCLUDED
(Free Callback Service & Additional Treatments, if required)	
Total Recurring Monthly Service Charges	\$ 4,145.00

*Services performed at FLORIDA WATERWAYS' sole discretion for the success of the Waterway Management Service Agreement.

3. FLORIDA WATERWAYS agrees to commence Waterway Management Services within fifteen (15) business days, weather permitting, from the date of receipt of this executed Agreement plus initial deposit and/or issuance of required government permits.

4. The terms and conditions appearing on the reverse side form an integral part of this Agreement, and CUSTOMER hereby acknowledges that they have read and are familiar with the contents thereof. Agreement must be accepted in its entirety to be considered valid.

By: _____
FLORIDA WATERWAYS

CUSTOMER

Jim Schwartz
Email: jim@floridalake.com

Printed: _____

Proposal Date: January 6, 2025

Dated: _____

The attached terms, conditions, and this Agreement shall have no further force and effect unless accepted and returned by CUSTOMER to FLORIDA WATERWAYS within seven (7) days from the effective proposal date.

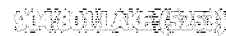

Exhibit B Map of Ponds

Waterway Map

Trailmark (Six Mile Creek CDD)



C.

MINUTES OF MEETING
SIX MILE CREEK
COMMUNITY DEVELOPMENT DISTRICT

The regular meeting of the Board of Supervisors of the Six Mile Creek Community Development District was held on Wednesday, January 8, 2025 at 2:00 p.m. at the Renaissance World Golf Village Resort, 500 South Legacy Trail, St. Augustine, Florida.

Present and constituting a quorum were:

Michelle Sutton	Chairperson
Heather Brofford	Vice Chairperson
Wendy Hartley	Supervisor
Jacob Dunn	Supervisor
Mindy Gellman	Supervisor

Also, present were:

Daniel Laughlin	District Manager
Kyle Magee <i>by phone</i>	District Counsel
Alex Boyer	Operations Manager
Nichola Balestra	OnPlace
Amanda Arnold <i>by phone</i>	OnPlace
Cassie Passantino	OnPlace
Matthew Reid	First Service, Reverie HOA
Sarah Sweeting	GMS
Joe Durkin	Brightview
Erica Graham <i>by phone</i>	Flock Security
Clayton Buss	CBuss

The following is a summary of the actions taken at the January 8, 2025 Six Mile Creek Community Development District's regular Board of Supervisor's Meeting.

FIRST ORDER OF BUSINESS

Roll Call

Mr. Laughlin called the meeting to order at 2:00 p.m. Five Supervisors were in attendance constituting a quorum.

SECOND ORDER OF BUSINESS

Audience Comments

Mr. Laughlin noted this is the audience’s opportunity to comment on items specific to today’s agenda.

Audience member commented on reoccurring issues with the guest policies in Reverie. She stated she and her husband want it restricted, and to have updated language on the number of guests allowed that can attend events or use facilities. She noted on several occasions non-members attended events. She added she has sent letters to the Board on this issue in the past. She explained specific events where non-members are attending events, she noted concerns about insurance, liability, no enforcement, and guest tags not working. She added another issue was the desire for the lap lane be open for fitness.

Resident (Lynn Cooper) stated she would like to see added guidelines on pool usage and more classes are needed. She noted guests are coming and it causes members to have to pay both places.

THIRD ORDER OF BUSINESS

Brightview Report

Mr. Durkin presented a brief landscape report to the Board. He noted from the Quality Inspection there were some quality concerns such as weed control and noted it will be applied on Monday. He added comments on grasses to be completed, maintenance items in green spaces, cutbacks in February, oak tree pruning, lake areas to be treated, beds treated for weeds, leaf build up around kayaks, other treatments and cutbacks to plants, and removal of moss build up.

Other proposals were suggested for clean-up and other specific tasks. Board suggested some areas for planting and sprucing up certain areas. Irrigation issues were discussed, technology discussion, re-strawing in February, landscape agreements, budget, contingency dollars, adding herbicides to weeds, recommendations to areas for improvement on rose bed, and a new proposal for the rose bed area. Other discussion was held on the problems with the areas such as irrigation, dog issues, the children at bus stop leaving trash, and pond area leaking issues.

FOURTH ORDER OF BUSINESS

Presentation Regarding License Plate Reader

Mr. Laughlin stated this presentation was on the license plate reader and Ms. Graham of Flock Security gave an overview of the license plate reader to include access controls, privacy, and safety issues.

The Board wanted to understand what they had in place currently and how this new system would work. Mr. Gerry stated he will contact SJCSO to attend the February meeting. Board member asked who would have the video and would they have access to view in special cases. Ms. Graham explained the video process and surveillance cameras.

Mr. Dunn asked about a survey to be provided to the residents. Media issues were discussed and having oversight on the security issues. The Board also discussed having information sent out to the community on the readers and surveillance. No action was taken at this time and this item was tabled.

FOURTH ORDER OF BUSINESS

Approval of Consent Agenda

A. Engineer Items – Requisition Summary

The requisition summary was reviewed to include the Requisition #171 for \$206,522.00, Requisition #201 for \$283,225, Requisitions #173 for \$801, & #174 for \$230.437, and Requisitions #95 for \$4,259.25, #96 for 16,587.05, and #97 for \$10,070, Requisitions #83A for \$13,611.50, #84A for \$16,752.76, #85A for \$98,446.35, and #86A for \$4,180, #13 for \$10,419.50.

It was noted the total was for \$903,372.95. There were no questions.

B. Ratification of Agreements/Proposals

1. HVAC Proposal from Artic Air

Mr. Laughlin provided the Artic proposal to the Board and noted it was for ratification because it was \$100 over the not to exceed amount. The warranty was discussed as to if it was 5 years or 10 years. There will be follow up on the actual warranty.

C. Approval of Minutes of the November 26, 2024 and December 11, 2024 Meetings

Mr. Laughlin presented the minutes of the November 26, 2024 and December 11, 2024 meetings. There were no questions.

D. Balance Sheet as of November 30, 2024 and Statement of Revenues and Expenses for the Period Ending November 30, 2024

Mr. Laughlin presented the balance sheet as of November 30, 2024 and the revenues and expenses are for the period ending November 30, 2024.

E. Assessment Receipt Schedule

Mr. Laughlin noted they were at 25% collected.

F. Check Register

Mr. Laughlin noted the check register totaled \$130,046.55

On MOTION by Ms. Hartley, seconded by Ms. Brofford, with all in favor, the Consent Agenda, was approved 5-0.

SIXTH ORDER OF BUSINESS

Consideration of Proposals for Lake Maintenance (TrailMark & Reverie)

- A. The Lake Doctors**
- B. Lake and Pond Remediation, Inc.**
- C. Sitex**
- D. Florida Waterways**
- E. Solitude**

Mr. Laughlin reviewed the five lake maintenance proposals for TrailMark and Reverie. He presented a summary sheet for the pricing and comparison. It was asked if there was a certain scope of services specified in the RFP. It was noted there was not an RFP put out, there was only a proposal for services. The process and services were explained. He described the total amount for each. The Board noted they were difficult to compare due to the difference in services. It was explained the problem in doing an RFP for specific service, but vendors present quotes for what they want. It was noted any vendor will come to the District when needed with no charge.

The statement was made that every company except Sitex came in under budget. The current vendor was discussed and the Board stated they had asked this vendor for carp to be installed, and the current vendor did not want to do this. They had asked Florida Waterway if they would install the carp. A spreadsheet was shared, and it reflected Florida Waterways was the best price.

After discussion the Board stated they were not happy with the current vendor and felt Florida Waterways had done a good job in presenting and understood they did good work. The Board stated Florida Waterways was local and wanted them to take the contract for lake maintenance. The Board wanted to terminate the current vendor. The Board authorized staff to send a 30-day termination notice to Sitex and approved entering into an agreement with Florida Waterways for pond maintenance in both TrailMark and Reverie.

On MOTION by Ms. Sutton, seconded by Ms. Hartley, with all in favor, the, to Terminate the Current Contract with Sitex and Accept the Proposal with Florida Waterways for Lake Maintenance (TrailMark & Reverie) was approved 5-0.

SEVENTH ORDER OF BUSINESS

Consideration of Increase for Lifestyles Manager (TrailMark)

The salary increase for the Lifestyles Manager was discussed to include her previous employment with Evergreen and OnPlace, services, facilities management, and a salary not to exceed \$98,000 for the position. It was noted this suggestion will go over that threshold with a total compensation of \$65,000 with insurance, payroll and taxes. Some concerns were expressed with the events in the community, the newsletter, the app, and lack of use by the community.

It was noted some of the events are planned by the developer, and there was confusion on what the Lifestyles Manager’s roles and responsibilities were. There was discussion of the \$5000 increase, the threshold of \$98,000 limit, the contract, OnPlace and amounts, and roles and responsibilities.

Mr. Magee explained the two separate amounts as far as payments. He noted the Lifestyle’s Manager’s salary may not exceed \$70,000 per year, not to include other taxes, etc. He explained with the consent of the District; total compensations may exceed the amount and can be explained. The Board referred to Page 149 which explains the compensation and all other fees.

Further discussion ensued on OnPlace as a vendor, how the contract was presented and some of the confusion with what was included in this contract. The Board would like to have specific rules and responsibilities, a job description, and noted the issues with having a Lifestyle Manager running the amenities of the CDD. They noted they are happy with the persons fulfilling the role, but not necessarily the management company. The roles, responsibilities, and job descriptions were reviewed.

After discussion the Board decided to approve the increase for the Lifestyles Manager with a not to exceed \$98,000 per current contract.

On MOTION by Ms. Sutton, seconded by Ms. Brofford, with all in favor, the Proposal for an Increase for the Lifestyles Manager with a Not to Exceed the \$98,000 per the Contract with the Included Burden, approved 5-0.

EIGHTH ORDER OF BUSINESS

Consideration of Disclosure of Public Financing

Mr. Magee reviewed the disclosure of Public Financing. He noted this is filed when bonds are issued and gives notice to the community and informs them of the plan. He asked for a motion to approve.

On MOTION by Ms. Sutton, seconded by Ms. Brofford, with all in favor, the Disclosure of Public Financing, was approved 5-0.

NINTH ORDER OF BUSINESS

Discussion Regarding Amenity Usage

Mr. Laughlin stated this item was regarding amenity usage and the issues with organized activities. Discussion ensued on the report of weekly usage of the amenity center, job descriptions, and ensuring compliance of rule and regulations. It was noted that the enforcement of policies is by the manager. Concerns were voiced on the Camphouse parties by reserving, others utilizing the area and not paying, organized sports occurring on field not going through vetting, instance of birthday parties, food trucks, church group and parking issues, rentals, reservations, and events needing reservations.

It was noted the Camphouse is for public events and should be used by public. Reservations should be made for exclusivity purposes. Reverie events were discussed, and the Board stated rules are needed for events. Discussion ensued on communication as an issue with the overall amenity usage, membership to the CDD, and staffing issues.

It was suggested with the growth of the community guidelines need to be put in place. Discussion ensued on using online reservations, pop-up events, controls and guidelines for usage of the amenities, review of policies, needing proper staff to enforce activities, costs for services, wanting to issue an RFP, and review of the scope.

Mr. Laughlin stated they would put together an RFP package for Board's review at the next meeting. Board member Gellman suggested that Reverie should have rules and requirements for the residents. It was suggested to be reviewed at the next meeting. They will start with what is posted online and the Board can make changes as needed.

TENTH ORDER OF BUSINESS

Consideration of Third Amendment to the Tree Amigos Landscape Agreement (Reverie)

Mr. Laughlin stated the current agreement with Tree Amigos has expired and this is to proceed with a month-by-month basis until new direction is established. This will approve an amendment to the contract with Tree Amigos for Reverie and extend their services through March 31, 2025.

On MOTION by Ms. Brofford, seconded by Ms. Gellman, with all in favor, the Third Amendment to the Tree Amigos Landscape Agreement, was approved 5-0.

ELEVENTH ORDER OF BUSINESS

Review of Scope of Services for Landscape & Irrigation Maintenance Services RFP (Reverie)

Mr. Laughlin reviewed the scope of services for landscape and irrigation maintenance services RFP in Reverie. He noted this had not changed and the services are what is currently being provided. He noted extra areas have been added and the map is included and shows maintained areas. He noted the companies will submit proposals to be brought to the February meeting. He added this does not require a motion, only Board authorization.

TWELFTH ORDER OF BUSINESS

Discussion of Pool Monitor for Spring Break

Mr. Laughlin reviewed a proposal from Elite Amenities for pool monitoring services for spring break. He noted the services will be from March 14th through the 23rd daily from 11:00am – 7:00pm. This will be for 1 pool monitor for \$2,132.80. He added the budget does include a pool monitor and services for the summer will be addressed at the next meeting.

Discussion was voiced on the concerns the Board had waited until the last minute for a plan, CPR certification is not required for this position, and they asked for feedback from residents on who’s doing a good job.

On MOTION by Ms. Sutton, seconded by Ms. Brofford with all in favor, the Proposal from Elite Amenities for Pool Monitoring Services for Spring Break, was approved 5-0.

THIRTEENTH ORDER OF BUSINESS Discussion of Pool Repairs (TrailMark)

Ms. Sutton noted the pool is needing services for repairs and the biggest issues are the expansion joints. It was noted they are not under warranty. She stated Mr. Buss will suggest using different materials that will fix the issue. She added the \$186,000 is for all the repairs to be completed and we are not currently budgeted for all of this. The expansion joints are what we will look at for repair.

Discussion ensued on the other pool vendors, the difference in the pricing, and work. Mr. Boyer explained the vendors use their own products and therefore this creates a price difference and an attempt at comparison. He explained the adhesion strip on the expansion joints are what is required. He noted this has needed repair each year.

Mr. Buss arrived late at the meeting and explained the process for repairs on the new expansions. He noted the pool would need to be closed for about 2 weeks for this work. He added the expansion joints will need to be replaced and pool resurfacing would need to be done. He explained this is a new product and it will hold up longer. He discussed other concerns, and issues on resurfacing process with pebbles. It was noted the life span could be up to 20 years. He current expansion joint and the coping strip is the problem.

Discussion ensued on other possibilities, two different quotes to include the basic and the pebbles, the pricing needed just for replacing the joints, moving forward to have pool open by spring break, pricing concerns, risk hazards, budgeting issues, compliance with standards, placements of expansion joints, patching to get through the summer, using capital expense and contingency money, waiting to complete 1 time, backsplash replacement options, and the incidents with damages to the pool need to be reported.

After discussion the Board asked for a proposal for pebble surfacing to plan into the FY26 budget.

FOURTEENTH ORDER OF BUSINESS Other Business

There being no comments, the next item followed.

FIFTEENTH ORDER OF BUSINESS Staff Reports

A. Attorney

Mr. Magee stated there were no further reports.

B. Engineer

Mr. Laughlin stated there was not an engineer present. The Board voiced concerns on a \$5,000 map and wanted a follow-up map from the engineer showing the inflow and outflow of ponds. The Board also wanted the developer to possibly contribute to the cost of providing the map.

C. Manager – Scheduling of a February Meeting

Mr. Laughlin stated the current meeting room is booked in February. After discussion of several issues the final determination was for the next meeting to be February 10, 2025 at 2:00 p.m. at the TrailMark Welcome Center. Mr. Dunn noted he will be out of town. The Board noted at this meeting they could determine the status of what is needed at the Welcome Center.

D. TrailMark Reports**1. Operations (*RealManage*) – Report**

There were no updates from TrailMark. It was asked that RealManage provide an update on mailboxes on Topiary. Water issues have created a need for shingles that will be needed, and they are waiting for quotes. The Board asked for an update on the incident with the tree and landscape median and then how to proceed. It was noted a police report was filed on property damage and insurance was discussed.

2. Lifestyles (*OnPlace*) – Report

Ms. Balestra provided an update on recent and upcoming events. She reported the reservations at the Camphouse and the checklist that is covered for rentals, and kayaks usage. Ms. Arnold reviewed the report from Stephanie with events, usage of the fields, reports to police, changes to policies, distribution of fobs, process of handling issues with people on CDD property, non-resident trespassing issues, creating a sign-in at the amenity center, sign-in at new field, and other possible changes to be made. Ms. Arnold stated other CDD's have policies, and enforcements are always an issue.

Mr. Boyer reviewed the fob process for HOA distribution to the property owner, and Board suggestion to change to having the CDD issue the fobs, requirements for fobs, and the process for both Six Mile and Reverie issuances of fobs.

After discussions the Board instructed OnPlace to handle the distribution of all key fobs.

E. Reverie Reports (First Service)**1. DFH Updates****2. Operations (*First Service*)**

An update was provided regarding the pool system maintenance to include upgrades on monitoring of the water system, new probes for water quality, safety issues, and the replacement of shower heads. He added winter seasonal landscaping duties to include cutting grasses, plantings, palm tree replacements, and seasonal flowers.

The Board asked for an update regarding the kitchen pass through renovation. It was noted there was an issue with the vendor, and he doesn't have an update. The Board expressed concerns with the emergency front entry gate not working and repairs are at the CDD costs. It was noted a remote is needed for emergencies and the Board would like an update at the next meeting.

3. Lifestyles (*OnPlace*)**1. Report**

Ms. Passantino provided an update on the specifics of recent and upcoming events at Reverie. She reviewed the number of reservations. She noted club classes have been occurring, and she has requested approval reserving the lap pool for water aerobics class on Saturdays for no charges. It was noted the instructor has provided her credentials, insurance, and Independent Contractor agreement.

Discussion ensued on usage, frequency of usage, the pool being taken 4 days a week, unfairness to residents, first-come-first serve basis, access to the lap pool, others providing classes in the pool, friends exercising in the main pool 2 days a week, and persons asking for permission to use the pool.

Mr. Magee explained how other Districts handled this issue with having the person come before the Board for approval for usage of the pool. He noted there are no systems using reservations for pool usage. Board members debated the issue, the need for making policies, starting a process for the issue, ceasing classes until Board approval, and using storage space for aerobics equipment.

2. Water Aerobics

After the above discussion this item was tabled until the February meeting for further discussion.

SIXTEENTH ORDER OF BUSINESS

Supervisor's Requests

Board oversight was discussed and assigning members to oversee specific areas. This will help in providing updates to the Board on the areas.

Board Oversight Assignments:

Supervisor Brofford – Pond Maintenance

Supervisor Sutton – Landscape Maintenance

Supervisor Dunn – TrailMark Amenity Center

Supervisor Gellman – Reverie Amenity Center

Supervisor Hartley – Lifestyles of TrailMark and Reverie

Board comments were made on invoices, furniture concepts, and developer proposing activities.

SEVENTEENTH ORDER OF BUSINESS

Audience Comments

- Audience member made comments on Board member emails not being user friendly to help connect with Board members, capital contingency fund questions, increase in lots increase funds, and the budget.
- Guest policy clarification on residents bringing guest, getting the calendar, and using facilities.
- Suggestions were made for having a time for guest sign-in or a waiver. The issue to solve was how to control the number of guests.
- Resident Jamie (Deja Brew) requested a time to park the food truck and sell coffee and pastries to the community. The Board authorized her to work with Stephanie on scheduling and providing the necessary documentation.
- Comments were made on the welcome center and improvements that need to be made.
- Resident commented on the bridge between the canal a landscaping issue, addressing the kayak launch, and updates on the truck that ran into the tree.

EIGHTEENTH ORDER OF BUSINESS

Next Scheduled Meeting – February 10, 2025 at 2:00 p.m. @ Renaissance World Golf Village Resort

The next regular meeting will be February 10, 2025, at 2:00 p.m. at the TrailMark Welcome Center.

NINTEENTH ORDER OF BUSINESS

Adjournment

Mr. Laughlin asked for a motion to adjourn.

On MOTION by Ms. Sutton, seconded by Ms. Brofford, with all in favor, the meeting adjourned.

1

Secretary/Assistant Secretary

Chairman/Vice Chairman

D.

Six Mile Creek
Community Development District

Unaudited Financial Reporting
December 31, 2024



Table of Contents

1-2	<u>Balance Sheet</u>
3-4	<u>General Fund Income Statement</u>
5-6	<u>General Fund Month to Month</u>
7-8	<u>Reverie Fund (East Parcel) Income Statement</u>
9-10	<u>Reverie (East Parcel) Month to Month</u>
11	<u>Capital Reserve Income Statement</u>
12	<u>Debt Service Series 2007 Income Statement</u>
13	<u>Debt Service Series 2015 Income Statement</u>
14	<u>Debt Service Series 2016A Income Statement</u>
15	<u>Debt Service Series 2016B Income Statement</u>
16	<u>Debt Service Series 2017A Income Statement</u>
17	<u>Debt Service Series 2020 Income Statement</u>
18	<u>Debt Service Series 2021 AA3 PH1 Income Statement</u>
19	<u>Debt Service Series 2021 AA3 PH2 Income Statement</u>
20	<u>Debt Service Series 2021 AA2 PH3B Income Statement</u>
21	<u>Debt Service Series 2023 AA2 PH3C/AA3 PH3 Income Statement</u>
22	<u>Debt Service Series 2024 Income Statement</u>
23	<u>Developer Contributions Schedule</u>
24	<u>Assessment Receipt Schedule</u>

Table of Contents

25	<u>Capital Projects Series 2007 Income Statement</u>
26	<u>Capital Projects Series 2016A Income Statement</u>
27	<u>Capital Projects Series 2016B Income Statement</u>
28	<u>Capital Projects Series 2017A Income Statement</u>
29	<u>Capital Projects Series 2020 Income Statement</u>
30	<u>Capital Projects Series 2021 AA3 PH1 Income Statement</u>
31	<u>Capital Projects Series 2021 AA3 PH2 Income Statement</u>
32	<u>Capital Projects Series 2021 AA2 PH3B Income Statement</u>
33	<u>Capital Projects Series 2023 AA2 PH3C/AA3 PH3 Income Statement</u>
34	<u>Capital Projects Series 2024 Income Statement</u>
35	<u>Series 2016A Construction Schedule</u>
36	<u>Series 2016B Construction Schedule</u>
37	<u>Series 2017A Construction Schedule</u>
38	<u>Series 2017A-NW Parcel Construction Schedule</u>
39	<u>Series 2020 Construction Schedule</u>
40	<u>Series 2021 AA3 PH1 Construction Schedule</u>
41	<u>Series 2021 AA3 PH2 Construction Schedule</u>
42	<u>Series 2021 AA2 PH3B Construction Schedule</u>
43	<u>Series 2023 AA2 PH3C Construction Schedule</u>
44	<u>Series 2023 AA3 PH3 Construction Schedule</u>
45	<u>Series 2024 Construction Schedule</u>

Six Mile Creek
Community Development District
Balance Sheet
December 31, 2024

	General Fund	Reverie Fund	Capital Reserve Fund	Debt Service Fund	Capital Projects Fund	Totals Governmental Funds
Assets:						
Cash - Truist Bank	\$ 70,827	\$ 98,987	\$ -	\$ -	\$ -	\$ 169,814
Cash - Truist Bank - Special Events	2,153	-	-	-	-	2,153
Assessment Receivable	-	-	-	-	-	-
Investments:						
Series 2007						
Reserve	-	-	-	28,065	-	28,065
Construction	-	-	-	-	2,405	2,405
Series 2015						
Reserve	-	-	-	157,219	-	157,219
Revenue	-	-	-	128,229	-	128,229
Prepayment	-	-	-	1	-	1
Series 2016A						
Reserve	-	-	-	432,044	-	432,044
Revenue	-	-	-	318,858	-	318,858
Construction	-	-	-	-	50,611	50,611
Series 2016B						
Revenue	-	-	-	171	-	171
Prepayment	-	-	-	6	-	6
Construction	-	-	-	-	4	4
Series 2017A						
Reserve	-	-	-	693,588	-	693,588
Revenue	-	-	-	320,140	-	320,140
Interest	-	-	-	0	-	0
Prepayment	-	-	-	29,224	-	29,224
Construction	-	-	-	-	0	0
Construction - NW	-	-	-	-	996	996
Series 2020						
Reserve	-	-	-	205,300	-	205,300
Revenue	-	-	-	196,110	-	196,110
Interest	-	-	-	1	-	1
Series 2021 AA3 PH1						
Reserve	-	-	-	282,825	-	282,825
Revenue	-	-	-	253,256	-	253,256
Construction	-	-	-	-	-	-
Series 2021 AA3 PH2						
Revenue	-	-	-	150,903	-	150,903
Prepayment	-	-	-	67,919	-	67,919
Construction	-	-	-	-	573	573
Series 2021 AA2 PH3B						
Reserve	-	-	-	230,438	-	230,438
Revenue	-	-	-	192,429	-	192,429
Construction	-	-	-	-	5	5
Series 2023						
Reserve	-	-	-	727,675	-	727,675
Revenue	-	-	-	110,803	-	110,803
Interest	-	-	-	-	-	-
Capitalized Interest	-	-	-	41	-	41
Construction AA2 PH3C	-	-	-	-	576	576
Construction AA3 PH3	-	-	-	-	5	5
Series 2024						
Reserve	-	-	-	193,130	-	193,130
Revenue	-	-	-	1,249	-	1,249
Capitalized Interest	-	-	-	167,421	-	167,421
Cost of Issuance	-	-	-	-	105	105
Investment - Custody	448,637	-	-	-	-	448,637
Due From Capital Projects	-	-	-	-	956	956
Due From Capital Reserve	8,752	-	-	-	-	8,752
Due From Developer	-	-	-	-	883,563	883,563
Due From General Fund	-	-	-	-	5,153	5,153
Due From Other	236	-	-	-	-	236
Prepaid Expenses	1,654	-	-	-	-	1,654
Total Assets	\$ 532,259	\$ 98,987	\$ -	\$ 4,887,044	\$ 944,952	\$ 6,463,242

Six Mile Creek
Community Development District
Balance Sheet
December 31, 2024

	General Fund	Reverie Fund	Capital Reserve Fund	Debt Service Fund	Capital Projects Fund	Totals Governmental Funds
Liabilities:						
Accounts Payable	\$ 72,402	\$ 55,856	\$ -	\$ -	\$ 893,563	\$ 1,021,821
Contracts Payable	-	-	-	-	1,102,495	1,102,495
Due to Capital Projects 2016A/B	4,153	-	-	-	-	4,153
Due to Capital Projects 2017	1,000	-	-	-	956	1,956
Due to General Fund	-	-	-	-	-	-
Due to Other	-	-	-	-	25,760	25,760
Total Liabilities	\$ 77,555	\$ 55,856	\$ -	\$ -	\$ 2,022,774	\$ 2,156,185
Fund Balances:						
Assigned For Debt Service 2007	\$ -	\$ -	\$ -	\$ 28,065	\$ -	\$ 28,065
Assigned For Debt Service 2015	-	-	-	285,448	-	285,448
Assigned For Debt Service 2016A	-	-	-	750,902	-	750,902
Assigned For Debt Service 2016B	-	-	-	177	-	177
Assigned For Debt Service 2017A	-	-	-	1,042,952	-	1,042,952
Assigned For Debt Service 2020	-	-	-	401,410	-	401,410
Assigned For Debt Service 2021 PH1	-	-	-	536,081	-	536,081
Assigned For Debt Service 2021 PH2	-	-	-	218,823	-	218,823
Assigned For Debt Service 2021 PH3B	-	-	-	422,867	-	422,867
Assigned For Debt Service 2023	-	-	-	838,520	-	838,520
Assigned For Debt Service 2024	-	-	-	361,800	-	361,800
Assigned For Capital Reserves 2007	-	-	-	-	2,405	2,405
Assigned For Capital Reserves 2016A	-	-	-	-	53,808	53,808
Assigned For Capital Reserves 2016B	-	-	-	-	4	4
Assigned For Capital Reserves 2017A	-	-	-	-	2,953	2,953
Assigned For Capital Reserves 2020	-	-	-	-	0	0
Assigned For Capital Reserves 2021 PH1	-	-	-	-	0	0
Assigned For Capital Reserves 2021 PH2	-	-	-	-	(229,936)	(229,936)
Assigned For Capital Reserves 2021 PH3B	-	-	-	-	(498,587)	(498,587)
Assigned For Capital Reserves 2023	-	-	-	-	(372,813)	(372,813)
Assigned For Capital Reserves 2024	-	-	-	-	(35,655)	(35,655)
Unassigned	454,704	43,132	-	-	-	497,836
Total Fund Balances	\$ 454,704	\$ 43,132	\$ -	\$ 4,887,044	\$ (1,077,822)	\$ 4,307,057
Total Liabilities & Fund Equity	\$ 532,259	\$ 98,987	\$ -	\$ 4,887,044	\$ 944,952	\$ 6,463,242

Six Mile Creek

Community Development District

General Fund

Statement of Revenues, Expenditures, and Changes in Fund Balance For The Period Ending December 31, 2024

	Adopted	Prorated Budget	Actual	
	Budget	Thru 12/31/24	Thru 12/31/24	Variance
Revenues:				
Special Assessments - Tax Roll	\$ 1,544,069	\$ 400,010	\$ 400,010	\$ -
Special Assessments - Direct Platted	351,132	87,783	87,783	-
Special Assessments - Direct Unplatted	21,329	5,332	5,332	-
Special Assessments - Lot Closings	-	-	35,895	35,895
Interest	24,000	24,000	2,529	(21,471)
Miscellaneous Income	1,226	1,226	275	(951)
Rental Income	3,000	3,000	1,810	(1,190)
Special Events Income	-	-	717	717
Total Revenues	\$ 1,944,756	\$ 521,352	\$ 534,352	\$ 13,000
Expenditures:				
Administrative:				
Supervisor Fees	\$ 12,000	\$ 3,000	\$ 2,600	\$ 400
FICA Expense	918	230	199	31
Engineering Fees	25,000	6,250	7,498	(1,248)
Attorney	35,000	8,750	4,289	4,461
Arbitrage	4,800	1,200	1,200	-
Dissemination	12,720	3,180	3,763	(583)
Dissemination - DTS	1,500	1,500	2,500	(1,000)
Annual Audit	14,500	-	-	-
Trustee Fees	30,170	7,273	7,273	-
Assessment Administration	10,000	10,000	10,000	-
Management Fees	45,000	11,250	11,250	-
Information Technology	1,890	473	473	-
Website Maintenance	1,260	315	315	-
Debt Service Fund Accounting	5,000	1,250	-	1,250
Telephone	1,000	250	221	29
Postage	1,750	438	890	(452)
Printing & Binding	1,750	438	463	(26)
Insurance	7,880	7,880	7,661	219
Legal Advertising	10,000	2,500	491	2,009
Meeting Room Rental	20,500	5,125	4,536	589
Bank Fees	3,000	750	500	250
Other Current Charges	300	75	100	(25)
Office Supplies	200	50	6	44
Dues, Licenses & Subscriptions	175	175	175	-
Total Administrative:	\$ 246,313	\$ 72,350	\$ 66,403	\$ 5,948
Operations & Maintenance				
Property Insurance	\$ 43,395	\$ 43,395	\$ 40,022	\$ 3,373
Electric	10,000	2,500	2,352	148
Streetlights	95,500	23,875	24,656	(781)
Landscape Contract	367,000	91,750	91,750	0
Landscape - Mulch & Plant Installation	120,000	30,000	2,176	27,824
Landscape Contingency	88,000	22,000	4,210	17,790
Lake Contract	50,000	12,500	12,660	(160)
Lake Contingency	10,000	2,500	-	2,500
Irrigation Maintenance	75,000	18,750	7,528	11,222
Repairs & Maintenance	15,000	3,750	-	3,750
Security Patrol	55,000	13,750	8,972	4,778
Dog Park - General Maintenance	5,000	1,250	618	632
Kayak Launch - General Maintenance	5,000	1,250	560	690
Storm Clean-Up/Tree Removal	30,000	7,500	18,330	(10,830)
Total Operations & Maintenance:	\$ 968,895	\$ 274,770	\$ 213,834	\$ 60,936

Six Mile Creek

Community Development District

General Fund

Statement of Revenues, Expenditures, and Changes in Fund Balance For The Period Ending December 31, 2024

	Adopted	Prorated Budget	Actual	
	Budget	Thru 12/31/24	Thru 12/31/24	Variance
<u>Amenity Center</u>				
<u>Utilities</u>				
Telephone/Internet	\$ 10,000	\$ 2,500	\$ 1,208	\$ 1,292
Electric	25,000	6,250	5,100	1,150
Water/Irrigation	45,000	11,250	8,918	2,332
Gas	2,000	500	201	299
Trash Removal	8,910	2,228	2,566	(339)
Security				
Security Alarm Monitoring	\$ 1,100	\$ 275	\$ 555	\$ (280)
Access Cards	1,000	250	-	250
Management Contracts				
Facility Management	\$ 125,000	\$ 31,250	\$ 23,677	\$ 7,573
Field Management/Administrative	112,320	28,080	14,850	13,230
Amenity Staff - Rentals	2,000	500	744	(244)
Onsite Reimbursable (Event Pgrm/Mileage/Cell)	2,000	500		
Pool Attendants	50,000	12,500	-	12,500
Pool Maintenance	40,000	10,000	5,400	4,600
Pool Repairs	30,000	7,500	5,442	2,059
Pool Permits	1,000	250	-	250
Janitorial Services	42,706	10,677	8,893	1,783
Fitness Equipment Lease	34,312	8,578	8,578	(0)
Pest Control	5,000	1,250	1,180	70
Repairs & Maintenance	40,000	10,000	4,069	5,931
Special Events	21,000	5,250	10,258	(5,008)
Holiday Decorations	12,000	3,000	-	3,000
Fitness Center Repairs/Supplies	3,500	875	175	700
Operating Supplies	10,000	2,500	667	1,833
ASCAP/BMI Licenses	1,700	425	23,210	(22,785)
Contingency	4,000	1,000	151	849
Total Amenity Center:	\$ 629,548	\$ 157,387	\$ 125,841	\$ 31,046
<u>Reserves</u>				
Capital Reserve Transfer	\$ 100,000	\$ -	\$ -	\$ -
Total Reserves	\$ 100,000	\$ -	\$ -	\$ -
Total Expenditures	\$ 1,944,756	\$ 504,507	\$ 406,078	\$ 97,929
Excess Revenues (Expenditures)	\$ -		\$ 128,274	
Fund Balance - Beginning	\$ -		\$ 326,430	
Fund Balance - Ending	\$ -		\$ 454,704	

Six Mile Creek
Community Development District
Month to Month

	Oct	Nov	Dec	Jan	Feb	Mar	Apr	May	Jun	Jul	Aug	Sept	Total
Revenues:													
Special Assessments - Tax Roll	\$ -	\$ 135,831	\$ 264,180	\$ -	\$ -	\$ -	\$ -	\$ -	\$ -	\$ -	\$ -	\$ -	400,010
Special Assessments - Direct Platted	87,783	-	-	-	-	-	-	-	-	-	-	-	87,783
Special Assessments - Direct Unplatted	5,332	-	-	-	-	-	-	-	-	-	-	-	5,332
Special Assessments - Lot Closings	20,163	-	15,733	-	-	-	-	-	-	-	-	-	35,895
Interest	1,140	681	708	-	-	-	-	-	-	-	-	-	2,529
Miscellaneous Income	275	-	-	-	-	-	-	-	-	-	-	-	275
Rental Income	1,567	242	-	-	-	-	-	-	-	-	-	-	1,810
Special Events Income	385	244	88	-	-	-	-	-	-	-	-	-	717
Total Revenues	\$ 116,645	\$ 136,999	\$ 280,708	\$ -	\$ -	\$ -	\$ -	\$ -	\$ -	\$ -	\$ -	\$ -	\$ 534,352
Expenditures:													
Administrative:													
Supervisor Fees	\$ -	\$ 1,000	\$ 1,600	\$ -	\$ -	\$ -	\$ -	\$ -	\$ -	\$ -	\$ -	\$ -	2,600
FICA Expense	-	77	122	-	-	-	-	-	-	-	-	-	199
Engineering Fees	2,091	2,172	3,236	-	-	-	-	-	-	-	-	-	7,498
Attorney	1,788	2,502	-	-	-	-	-	-	-	-	-	-	4,289
Arbitrage	-	-	1,200	-	-	-	-	-	-	-	-	-	1,200
Dissemination	1,560	1,060	1,143	-	-	-	-	-	-	-	-	-	3,763
Dissemination - DTS	2,500	-	-	-	-	-	-	-	-	-	-	-	2,500
Annual Audit	-	-	-	-	-	-	-	-	-	-	-	-	-
Trustee Fees	-	-	7,273	-	-	-	-	-	-	-	-	-	7,273
Assessment Administration	10,000	-	-	-	-	-	-	-	-	-	-	-	10,000
Management Fees	3,750	3,750	3,750	-	-	-	-	-	-	-	-	-	11,250
Information Technology	158	158	158	-	-	-	-	-	-	-	-	-	473
Website Maintenance	105	105	105	-	-	-	-	-	-	-	-	-	315
Debt Services Fund Accounting	-	-	-	-	-	-	-	-	-	-	-	-	-
Telephone	81	67	72	-	-	-	-	-	-	-	-	-	221
Postage	5	794	91	-	-	-	-	-	-	-	-	-	890
Printing & Binding	169	134	161	-	-	-	-	-	-	-	-	-	463
Insurance	7,661	-	-	-	-	-	-	-	-	-	-	-	7,661
Legal Advertising	360	66	66	-	-	-	-	-	-	-	-	-	491
Meeting Room Rental	-	3,119	1,418	-	-	-	-	-	-	-	-	-	4,536
Bank Fees	189	159	152	-	-	-	-	-	-	-	-	-	500
Other Current Charges	-	-	100	-	-	-	-	-	-	-	-	-	100
Office Supplies	3	1	3	-	-	-	-	-	-	-	-	-	6
Dues, Licenses & Subscriptions	175	-	-	-	-	-	-	-	-	-	-	-	175
Total Administrative:	\$ 30,594	\$ 15,161	\$ 20,648	\$ -	\$ -	\$ -	\$ -	\$ -	\$ -	\$ -	\$ -	\$ -	\$ 66,403
Operations & Maintenance													
Property Insurance	\$ 40,022	\$ -	\$ -	\$ -	\$ -	\$ -	\$ -	\$ -	\$ -	\$ -	\$ -	\$ -	40,022
Electric	822	989	542	-	-	-	-	-	-	-	-	-	2,352
Streetlights	8,219	8,219	8,219	-	-	-	-	-	-	-	-	-	24,656
Landscape Contract	30,583	30,583	30,583	-	-	-	-	-	-	-	-	-	91,750
Landscape - Mulch & Plant Installation	-	-	2,176	-	-	-	-	-	-	-	-	-	2,176
Landscape Contingency	-	2,520	1,690	-	-	-	-	-	-	-	-	-	4,210
Lake Contract	4,220	4,220	4,220	-	-	-	-	-	-	-	-	-	12,660
Lake Contingency	-	-	-	-	-	-	-	-	-	-	-	-	-
Irrigation Maintenance	1,814	2,143	3,571	-	-	-	-	-	-	-	-	-	7,528
Repairs & Maintenance	-	-	-	-	-	-	-	-	-	-	-	-	-
Security Patrol	2,567	3,370	3,035	-	-	-	-	-	-	-	-	-	8,972
Dog Park - General Maintenance	206	206	206	-	-	-	-	-	-	-	-	-	618
Kayak Launch - General Maintenance	560	-	-	-	-	-	-	-	-	-	-	-	560
Storm Clean-Up/Tree Removal	6,920	11,410	-	-	-	-	-	-	-	-	-	-	18,330
Total Operations & Maintenance:	\$ 95,933	\$ 63,659	\$ 54,242	\$ -	\$ -	\$ -	\$ -	\$ -	\$ -	\$ -	\$ -	\$ -	\$ 213,834

Six Mile Creek
Community Development District
Month to Month

	Oct	Nov	Dec	Jan	Feb	Mar	Apr	May	Jun	Jul	Aug	Sept	Total
<u>Amenity Center</u>													
<u>Utilities</u>													
Telephone/Internet	\$ 428	\$ 390	\$ 390	\$ -	\$ -	\$ -	\$ -	\$ -	\$ -	\$ -	\$ -	\$ -	1,208
Electric	1,608	1,705	1,788	-	-	-	-	-	-	-	-	-	5,100
Water/Irrigation	3,408	2,813	2,697	-	-	-	-	-	-	-	-	-	8,918
Gas	78	9	114	-	-	-	-	-	-	-	-	-	201
Trash Removal	946	673	946	-	-	-	-	-	-	-	-	-	2,566
<u>Security</u>													
Security Alarm Monitoring	\$ 35	\$ 35	\$ 485	\$ -	\$ -	\$ -	\$ -	\$ -	\$ -	\$ -	\$ -	\$ -	555
Access Cards	-	-	-	-	-	-	-	-	-	-	-	-	-
<u>Management Contracts</u>													
Facility Management	\$ 10,709	\$ -	\$ 12,969	\$ -	\$ -	\$ -	\$ -	\$ -	\$ -	\$ -	\$ -	\$ -	23,677
Field Management/Administrative	4,793	5,651	4,406	-	-	-	-	-	-	-	-	-	14,850
Amenity Staff - Rentals	248	331	165	-	-	-	-	-	-	-	-	-	744
<u>Onsite Reimbursable (Event Prgm/Mileage)</u>													
Pool Attendants	\$ -	\$ -	\$ -	\$ -	\$ -	\$ -	\$ -	\$ -	\$ -	\$ -	\$ -	\$ -	-
Pool Maintenance	1,800	1,800	1,800	-	-	-	-	-	-	-	-	-	5,400
Pool Repairs	2,309	2,387	745	-	-	-	-	-	-	-	-	-	5,442
Pool Permits	-	-	-	-	-	-	-	-	-	-	-	-	-
Janitorial Services	2,945	2,945	3,003	-	-	-	-	-	-	-	-	-	8,893
Fitness Equipment Lease	2,859	2,859	2,859	-	-	-	-	-	-	-	-	-	8,578
Pest Control	297	297	587	-	-	-	-	-	-	-	-	-	1,180
Repairs & Maintenance	2,130	986	953	-	-	-	-	-	-	-	-	-	4,069
Special Events	2,338	3,259	4,661	-	-	-	-	-	-	-	-	-	10,258
Holiday Decorations	-	-	-	-	-	-	-	-	-	-	-	-	-
Fitness Center Repairs/Supplies	175	-	-	-	-	-	-	-	-	-	-	-	175
Operating Supplies	295	-	372	-	-	-	-	-	-	-	-	-	667
ASCAP/BMI Licenses	23,210	-	-	-	-	-	-	-	-	-	-	-	23,210
Contingency	151	-	-	-	-	-	-	-	-	-	-	-	151
Total Amenity Center:	\$ 60,762	\$ 26,139	\$ 38,940	\$ -	\$ -	\$ -	\$ -	\$ -	\$ -	\$ -	\$ -	\$ -	125,841
<u>Reserves</u>													
Capital Reserves Transfer	\$ -	\$ -	\$ -	\$ -	\$ -	\$ -	\$ -	\$ -	\$ -	\$ -	\$ -	\$ -	-
Total Reserves:	\$ -	\$ -	\$ -	\$ -	\$ -	\$ -	\$ -	\$ -	\$ -	\$ -	\$ -	\$ -	-
Total Expenditures	\$ 187,289	\$ 104,960	\$ 113,829	\$ -	\$ -	\$ -	\$ -	\$ -	\$ -	\$ -	\$ -	\$ -	406,078
Excess Revenues (Expenditures)	\$ (70,644)	\$ 32,039	\$ 166,879	\$ -	\$ -	\$ -	\$ -	\$ -	\$ -	\$ -	\$ -	\$ -	128,274

Six Mile Creek

Community Development District

Reverie Fund

Statement of Revenues, Expenditures, and Changes in Fund Balance For The Period Ending December 31, 2024

	Adopted Budget	Prorated Budget Thru 12/31/24	Actual Thru 12/31/24	Variance
Revenues:				
Special Assessments - Tax Roll	\$ 403,920	\$ 104,640	\$ 104,640	\$ -
Special Assessments - Direct Billed	185,640	46,410	46,410	-
Developer Contributions	357,273	89,318	100,000	10,682
Interest	100	25	-	(25)
Miscellaneous Income	500	125	500	375
Total Revenues	\$ 947,433	\$ 240,518	\$ 251,550	\$ 11,032
Expenditures:				
Administrative:				
Other Current Charges	\$ 1,500	\$ 375	\$ 433	\$ (58)
Total Administrative:	\$ 1,500	\$ 375	\$ 433	\$ (58)
Operations & Maintenance				
Property Insurance	\$ 80,660	\$ 80,660	\$ 74,391	\$ 6,269
Electric	8,500	2,125	2,349	(224)
Landscape Contract	113,000	28,250	28,266	(16)
Landscape - Mulch & Plant Installation	45,000	11,250	-	11,250
Landscape Contingency	15,000	3,750	3,786	(36)
Lake Contract	14,000	3,500	3,492	8
Lake Contingency	2,500	625	-	625
Irrigation Maintenance	11,250	2,813	531	2,282
Repairs & Maintenance	1,500	375	-	375
Pump Repairs	1,500	375	-	375
Electric Streetlights/Services	5,000	1,250	-	1,250
Routine Road Cleaning	2,500	625	-	625
Dog Park - General Maintenance	6,000	1,500	1,446	54
Pavilion Park Maintenance	3,500	875	-	875
Entry Gate(s) Access Control & Monitoring	42,500	10,625	16,845	(6,220)
Contingency	5,000	1,250	1,574	(324)
Total Operations & Maintenance:	\$ 357,410	\$ 149,848	\$ 132,680	\$ 17,168

Six Mile Creek

Community Development District

Reverie Fund

Statement of Revenues, Expenditures, and Changes in Fund Balance For The Period Ending December 31, 2024

	Adopted Budget	Prorated Budget Thru 12/31/24	Actual Thru 12/31/24	Variance
<i>Amenity Center</i>				
<i>Utilities</i>				
Telephone/Internet	\$ 4,750	\$ 1,188	\$ 1,170	\$ 17
Electric	20,000	5,000	4,334	666
Water/Irrigation	20,000	5,000	10,250	(5,250)
Gas	32,250	8,063	5,123	2,939
Trash Removal	4,500	1,125	945	180
<i>Security</i>				
Security Alarm Monitoring	\$ 1,000	\$ 250	\$ 493	\$ (243)
Access Cards	5,000	1,250	-	1,250
<i>Management Contracts</i>				
Lifestyle Director	\$ 81,900	\$ 20,475	\$ 18,001	\$ 2,474
Admin (Facility Management)	63,312	15,828	7,124	8,704
Building Maintenance (Field Management)	88,919	22,230	20,824	1,405
Onsite Reimbursable (CAM/Medical/Mileage/Cell)	40,000	10,000	-	10,000
Landscape Contract	32,845	8,211	8,211	0
Landscape Seasonal	24,000	6,000	16,236	(10,236)
Landscape Contingency	4,000	1,000	1,200	(200)
Pool Maintenance	25,500	6,375	7,199	(824)
Pool Repairs	12,500	3,125	11,709	(8,584)
Pool Permits	1,000	250	-	250
Janitorial Services	7,750	1,938	4,200	(2,262)
Janitorial Supplies	4,750	1,188	91	1,097
Facility Repairs & Maintenance	25,000	6,250	3,517	2,733
Fitness Equipment Lease	27,347	6,837	6,837	0
Pest Control	2,200	550	225	325
Repairs & Maintenance	13,250	3,313	3,599	(286)
Special Events	35,000	8,750	20,032	(11,282)
Holiday Decorations	6,500	1,625	-	1,625
Dues, Licenses & Subscriptions	250	250	214	36
Operating Supplies	5,000	1,250	1,581	(331)
Total Amenity Center:	\$ 588,523	\$ 147,318	\$ 153,116	\$ (5,798)
Total Expenditures	\$ 947,433	\$ 297,541	\$ 286,229	\$ 11,312
Excess Revenues (Expenditures)	\$ -		\$ (34,679)	
Fund Balance - Beginning	\$ -		\$ 77,811	
Fund Balance - Ending	\$ -		\$ 43,132	

Six Mile Creek
Community Development District

Month to Month

	Oct	Nov	Dec	Jan	Feb	Mar	Apr	May	Jun	Jul	Aug	Sept	Total
Revenues:													
Special Assessments - Tax Roll	\$ -	\$ 35,532	\$ 69,108	\$ -	\$ -	\$ -	\$ -	\$ -	\$ -	\$ -	\$ -	\$ -	\$ 104,640
Special Assessments - Direct Billed	46,410	-	-	-	-	-	-	-	-	-	-	-	46,410
Developer Contributions	-	100,000	-	-	-	-	-	-	-	-	-	-	100,000
Interest	-	-	-	-	-	-	-	-	-	-	-	-	-
Miscellaneous Income	225	125	150	-	-	-	-	-	-	-	-	-	500
Total Revenues	\$ 46,635	\$ 135,657	\$ 69,258	\$ -	\$ -	\$ -	\$ -	\$ -	\$ -	\$ -	\$ -	\$ -	\$ 251,550
Expenditures:													
Administrative:													
Other Current Charges	\$ 115	\$ 176	\$ 142	\$ -	\$ -	\$ -	\$ -	\$ -	\$ -	\$ -	\$ -	\$ -	\$ 433
Total Administrative:	\$ 115	\$ 176	\$ 142	\$ -	\$ -	\$ -	\$ -	\$ -	\$ -	\$ -	\$ -	\$ -	\$ 433
Operations & Maintenance													
Property Insurance	\$ 74,391	\$ -	\$ -	\$ -	\$ -	\$ -	\$ -	\$ -	\$ -	\$ -	\$ -	\$ -	\$ 74,391
Electric	505	1,085	758	-	-	-	-	-	-	-	-	-	2,349
Landscape Contract	9,422	9,422	9,422	-	-	-	-	-	-	-	-	-	28,266
Landscape - Mulch & Plant Installation	-	-	-	-	-	-	-	-	-	-	-	-	-
Landscape Contingency	2,336	1,450	-	-	-	-	-	-	-	-	-	-	3,786
Lake Contract	1,164	1,164	1,164	-	-	-	-	-	-	-	-	-	3,492
Lake Contingency	-	-	-	-	-	-	-	-	-	-	-	-	-
Irrigation Maintenance	404	127	-	-	-	-	-	-	-	-	-	-	531
Repairs & Maintenance	-	-	-	-	-	-	-	-	-	-	-	-	-
Pump Repairs	-	-	-	-	-	-	-	-	-	-	-	-	-
Electric Streetlights/Services	-	-	-	-	-	-	-	-	-	-	-	-	-
Routine Road Cleaning	-	-	-	-	-	-	-	-	-	-	-	-	-
Dog Park - General Maintenance	482	482	482	-	-	-	-	-	-	-	-	-	1,446
Pavilion Park Maintenance	-	-	-	-	-	-	-	-	-	-	-	-	-
Entry Gate(s) Access Control & Monitoring	5,696	6,414	4,736	-	-	-	-	-	-	-	-	-	16,845
Contingency	232	621	721	-	-	-	-	-	-	-	-	-	1,574
Total Operations & Maintenance:	\$ 94,632	\$ 20,765	\$ 17,283	\$ -	\$ -	\$ -	\$ -	\$ -	\$ -	\$ -	\$ -	\$ -	\$ 132,680

Six Mile Creek
Community Development District

Month to Month

	Oct	Nov	Dec	Jan	Feb	Mar	Apr	May	Jun	Jul	Aug	Sept	Total
<u>Amenity Center</u>													
<u>Utilities</u>													
Telephone/Internet	\$ 389	\$ 390	\$ 390	\$ -	\$ -	\$ -	\$ -	\$ -	\$ -	\$ -	\$ -	\$ -	1,170
Electric	1,447	1,417	1,471	-	-	-	-	-	-	-	-	-	4,334
Water/Irrigation	2,767	4,151	3,332	-	-	-	-	-	-	-	-	-	10,250
Gas	431	118	4,575	-	-	-	-	-	-	-	-	-	5,123
Trash Removal	315	315	315	-	-	-	-	-	-	-	-	-	945
<u>Security</u>													
Security Alarm Monitoring	\$ 493	\$ -	\$ -	\$ -	\$ -	\$ -	\$ -	\$ -	\$ -	\$ -	\$ -	\$ -	493
Access Cards	-	-	-	-	-	-	-	-	-	-	-	-	-
<u>Management Contracts</u>													
Lifestyle Director	\$ 6,001	\$ 6,000	\$ 6,000	\$ -	\$ -	\$ -	\$ -	\$ -	\$ -	\$ -	\$ -	\$ -	18,001
Admin (Facility Management)	-	-	7,124	-	-	-	-	-	-	-	-	-	7,124
Building Maintenance (Field Management)	11,249	5,488	4,088	-	-	-	-	-	-	-	-	-	20,824
Onsite Reimbursable (CAM/Medical/Mileage)	-	-	-	-	-	-	-	-	-	-	-	-	-
Landscape Contract	2,737	2,737	2,737	-	-	-	-	-	-	-	-	-	8,211
Landscape Seasonal	3,521	6,200	6,515	-	-	-	-	-	-	-	-	-	16,236
Landscape Contingency	1,200	-	-	-	-	-	-	-	-	-	-	-	1,200
Pool Maintenance	3,079	2,060	2,060	-	-	-	-	-	-	-	-	-	7,199
Pool Repairs	8,706	792	2,211	-	-	-	-	-	-	-	-	-	11,709
Pool Permits	-	-	-	-	-	-	-	-	-	-	-	-	-
Janitorial Services	1,400	1,400	1,400	-	-	-	-	-	-	-	-	-	4,200
Janitorial Supplies	-	-	91	-	-	-	-	-	-	-	-	-	91
Facility Repairs & Maintenance	2,499	939	80	-	-	-	-	-	-	-	-	-	3,517
Fitness Equipment Lease	2,279	2,279	2,279	-	-	-	-	-	-	-	-	-	6,837
Pest Control	75	75	75	-	-	-	-	-	-	-	-	-	225
Repairs & Maintenance	3,175	124	300	-	-	-	-	-	-	-	-	-	3,599
Special Events	3,960	12,659	3,414	-	-	-	-	-	-	-	-	-	20,032
Holiday Decorations	-	-	-	-	-	-	-	-	-	-	-	-	-
Dues, Licenses & Subscriptions	179	-	35	-	-	-	-	-	-	-	-	-	214
Operating Supplies	878	401	302	-	-	-	-	-	-	-	-	-	1,581
Total Amenity Center:	\$ 56,779	\$ 47,545	\$ 48,792	\$ -	\$ -	\$ -	\$ -	\$ -	\$ -	\$ -	\$ -	\$ -	\$ 153,116
Total Expenditures	\$ 151,525	\$ 68,486	\$ 66,218	\$ -	\$ -	\$ -	\$ -	\$ -	\$ -	\$ -	\$ -	\$ -	\$ 286,229
Excess Revenues (Expenditures)	\$ (104,890)	\$ 67,171	\$ 3,040	\$ -	\$ -	\$ -	\$ -	\$ -	\$ -	\$ -	\$ -	\$ -	\$ (34,679)

Six Mile Creek

Community Development District

Capital Reserve

Statement of Revenues, Expenditures, and Changes in Fund Balance For The Period Ending December 31, 2024

	Adopted Budget	Prorated Budget Thru 12/31/24	Actual Thru 12/31/24	Variance
Revenues:				
Transfer In	\$ 100,000	\$ -	\$ -	\$ -
Interest	250	63	-	(63)
Total Revenues	\$ 100,250	\$ 63	\$ -	\$ (63)
Expenditures:				
Capital Outlay	\$ -	\$ -	\$ -	\$ -
Total Expenditures	\$ -	\$ -	\$ -	\$ -
Excess Revenues (Expenditures)	\$ 100,250	\$ 63	\$ -	
Fund Balance - Beginning	\$ 50,423		\$ -	
Fund Balance - Ending	\$ 150,673		\$ -	

Six Mile Creek

Community Development District

Debt Service Fund - Series 2007

Statement of Revenues, Expenditures, and Changes in Fund Balance For The Period Ending December 31, 2024

	Adopted		Prorated Budget		Actual		Variance
	Budget		Thru 12/31/24		Thru 12/31/24		
Revenues:							
Interest	\$	-	\$	-	\$	331	\$ 331
Total Revenues	\$	-	\$	-	\$	331	\$ 331
Expenditures:							
Series 2007							
Debt Service Obligation	\$	-	\$	-	\$	-	\$ -
Total Expenditures	\$	-	\$	-	\$	-	\$ -
Excess Revenues (Expenditures)	\$	-			\$	331	
Fund Balance - Beginning	\$	-			\$	27,734	
Fund Balance - Ending	\$	-			\$	28,065	

Six Mile Creek

Community Development District

Debt Service Fund - Series 2015

Statement of Revenues, Expenditures, and Changes in Fund Balance

For The Period Ending December 31, 2024

	Adopted Budget	Prorated Budget Thru 12/31/24	Actual Thru 12/31/24	Variance
Revenues:				
Special Assessments	\$ 209,625	\$ 55,203	\$ 55,203	\$ -
Interest	11,500	2,875	3,012	137
Total Revenues	\$ 221,125	\$ 58,078	\$ 58,215	\$ 137
Expenditures:				
Series 2015				
Interest - 11/01	\$ 51,797	\$ 51,797	\$ 51,797	\$ -
Special Call - 11/01	-	-	5,000	(5,000)
Principal - 05/01	105,000	-	-	-
Interest - 05/01	51,797	-	-	-
Total Expenditures	\$ 208,594	\$ 51,797	\$ 56,797	\$ (5,000)
Excess Revenues (Expenditures)	\$ 12,531		\$ 1,418	
Fund Balance - Beginning	\$ 121,725		\$ 284,030	
Fund Balance - Ending	\$ 134,256		\$ 285,448	

Six Mile Creek

Community Development District

Debt Service Fund - Series 2016A

Statement of Revenues, Expenditures, and Changes in Fund Balance For The Period Ending December 31, 2024

	Adopted Budget	Prorated Budget Thru 12/31/24	Actual Thru 12/31/24	Variance
Revenues:				
Special Assessments	\$ 432,044	\$ 112,891	\$ 112,891	\$ -
Interest	36,000	9,000	9,805	805
Total Revenues	\$ 468,044	\$ 121,891	\$ 122,696	\$ 805
Expenditures:				
Series 2016A				
Interest - 11/01	\$ 154,316	\$ 154,316	\$ 154,316	\$ -
Principal - 11/01	120,000	120,000	120,000	-
Special Call -11/01	-	-	5,000	(5,000)
Interest - 05/01	151,466	-	-	-
Total Expenditures	\$ 425,781	\$ 274,316	\$ 279,316	\$ (5,000)
Excess Revenues (Expenditures)	\$ 42,263		\$ (156,620)	
Fund Balance - Beginning	\$ 459,721		\$ 907,521	
Fund Balance - Ending	\$ 501,984		\$ 750,902	

Six Mile Creek

Community Development District

Debt Service Fund - Series 2016B

Statement of Revenues, Expenditures, and Changes in Fund Balance For The Period Ending December 31, 2024

	Adopted Budget	Prorated Budget Thru 12/31/24	Actual Thru 12/31/24	Variance
Revenues:				
Interest	\$ -	\$ -	\$ 2	\$ 2
Total Revenues	\$ -	\$ -	\$ 2	\$ 2
Expenditures:				
Series 2016B				
Interest - 11/01	\$ -	\$ -	\$ -	\$ -
Principal - 11/01	-	-	-	-
Interest - 05/01	-	-	-	-
Total Expenditures	\$ -	\$ -	\$ -	\$ -
Excess Revenues (Expenditures)	\$ -		\$ 2	
Fund Balance - Beginning	\$ -		\$ 175	
Fund Balance - Ending	\$ -		\$ 177	

Six Mile Creek

Community Development District

Debt Service Fund - Series 2017A

Statement of Revenues, Expenditures, and Changes in Fund Balance For The Period Ending December 31, 2024

	Adopted Budget	Prorated Budget Thru 12/31/24	Actual Thru 12/31/24	Variance
Revenues:				
Special Assessments	\$ 693,588	\$ 180,142	\$ 180,142	\$ -
Special Assessments - Prepayments	-	-	29,224	29,224
Interest	51,000	12,750	13,540	790
Total Revenues	\$ 744,588	\$ 192,892	\$ 222,907	\$ 30,015
Expenditures:				
Series 2017A				
Interest - 11/01	\$ 244,294	\$ 244,294	\$ 244,294	\$ -
Principal - 11/01	205,000	205,000	205,000	-
Special Call - 11/01	-	-	5,000	(5,000)
Interest - 05/01	239,681	-	-	-
Total Expenditures	\$ 688,975	\$ 449,294	\$ 454,294	\$ (5,000)
Excess Revenues (Expenditures)	\$ 55,613		\$ (231,387)	
Fund Balance - Beginning	\$ 564,155		\$ 1,274,339	
Fund Balance - Ending	\$ 619,768		\$ 1,042,952	

Six Mile Creek

Community Development District

Debt Service Fund - Series 2020

Statement of Revenues, Expenditures, and Changes in Fund Balance For The Period Ending December 31, 2024

	Adopted	Prorated Budget	Actual	
	Budget	Thru 12/31/24	Thru 12/31/24	Variance
Revenues:				
Special Assessments	\$ 410,600	\$ 106,466	\$ 106,466	\$ -
Interest	33,500	8,375	8,111	(264)
Total Revenues	\$ 444,100	\$ 114,841	\$ 114,576	\$ (264)
Expenditures:				
Series 2020				
Interest - 11/01	\$ 133,109	\$ 133,109	\$ 133,109	\$ -
Principal - 11/01	145,000	145,000	145,000	-
Special Call - 11/01	-	-	5,000	(5,000)
Interest - 05/01	130,844	-	-	-
Total Expenditures	\$ 408,953	\$ 278,109	\$ 283,109	\$ (5,000)
Other Sources/(Uses)				
Transfer In/(Out)	\$ -	\$ -	\$ (205,300)	\$ 205,300
Total Other Financing Sources (Uses)	\$ -	\$ -	\$ (205,300)	\$ 205,300
Excess Revenues (Expenditures)	\$ 35,147		\$ (373,833)	
Fund Balance - Beginning	\$ 358,875		\$ 775,243	
Fund Balance - Ending	\$ 394,022		\$ 401,410	

Six Mile Creek

Community Development District

Debt Service Fund - Series 2021 AA3 PH1

Statement of Revenues, Expenditures, and Changes in Fund Balance For The Period Ending December 31, 2024

	Adopted	Prorated Budget	Actual	
	Budget	Thru 12/31/24	Thru 12/31/24	Variance
Revenues:				
Special Assessments	\$ 566,300	\$ 148,373	\$ 148,373	\$ -
Interest	35,500	8,875	9,361	486
Total Revenues	\$ 601,800	\$ 157,248	\$ 157,734	\$ 486
Expenditures:				
Series 2021 AA3 PH1				
Interest - 11/01	\$ 172,900	\$ 172,900	\$ 172,525	\$ 375
Special Call - 11/01	-	-	5,000	(5,000)
Principal - 05/01	220,000	-	-	-
Interest - 05/01	172,900	-	-	-
Special Call - 05/01	-	-	-	-
Total Expenditures	\$ 565,800	\$ 172,900	\$ 177,525	\$ (4,625)
Other Sources/(Uses)				
Transfer In/(Out)	\$ -	\$ -	\$ (282,613)	\$ 282,613
Total Other Financing Sources (Uses)	\$ -	\$ -	\$ (282,613)	\$ 282,613
Excess Revenues (Expenditures)	\$ 36,000		\$ (302,403)	
Fund Balance - Beginning	\$ 284,502		\$ 838,484	
Fund Balance - Ending	\$ 320,502		\$ 536,081	

Six Mile Creek

Community Development District

Debt Service Fund - Series 2021 AA3 PH2

Statement of Revenues, Expenditures, and Changes in Fund Balance For The Period Ending December 31, 2024

	Adopted Budget	Prorated Budget Thru 12/31/24	Actual Thru 12/31/24	Variance
Revenues:				
Special Assessments	\$ 149,100	\$ 38,625	\$ 38,625	\$ -
Interest	13,700	3,425	2,517	(908)
Total Revenues	\$ 162,800	\$ 42,050	\$ 41,142	\$ (908)
Expenditures:				
Series 2021 AA3 PH2				
Interest - 11/01	\$ 46,065	\$ 46,065	\$ 46,065	\$ -
Principal - 05/01	55,000	-	-	-
Interest - 05/01	46,065	-	-	-
Total Expenditures	\$ 147,130	\$ 46,065	\$ 46,065	\$ -
Excess Revenues (Expenditures)	\$ 15,670		\$ (4,923)	
Fund Balance - Beginning	\$ 72,869		\$ 223,745	
Fund Balance - Ending	\$ 88,539		\$ 218,823	

Six Mile Creek

Community Development District

Debt Service Fund - Series 2021 AA2 PH3B

Statement of Revenues, Expenditures, and Changes in Fund Balance For The Period Ending December 31, 2024

	Adopted	Prorated Budget	Actual	
	Budget	Thru 12/31/24	Thru 12/31/24	Variance
Revenues:				
Special Assessments	\$ 460,875	\$ 119,391	\$ 119,391	\$ -
Interest	24,000	6,000	7,480	1,480
Total Revenues	\$ 484,875	\$ 125,391	\$ 126,871	\$ 1,480
Expenditures:				
Series 2021 AA2 PH3B				
Interest - 11/01	\$ 143,750	\$ 143,750	\$ 143,750	\$ -
Principal - 05/01	175,000	-	-	-
Interest - 05/01	143,750	-	-	-
Total Expenditures	\$ 462,500	\$ 143,750	\$ 143,750	\$ -
Other Sources/(Uses)				
Transfer In/(Out)	\$ -	\$ -	\$ (230,438)	\$ 230,438
Total Other Financing Sources (Uses)	\$ -	\$ -	\$ (230,438)	\$ 230,438
Excess Revenues (Expenditures)	\$ 22,375		\$ (247,316)	
Fund Balance - Beginning	\$ 203,716		\$ 670,183	
Fund Balance - Ending	\$ 226,091		\$ 422,867	

Six Mile Creek

Community Development District

Debt Service Fund - Series 2023

Statement of Revenues, Expenditures, and Changes in Fund Balance For The Period Ending December 31, 2024

	Adopted Budget	Prorated Budget Thru 12/31/24	Actual Thru 12/31/24	Variance
Revenues:				
Special Assessments	\$ 727,675	\$ -	\$ -	\$ -
Special Assessments - Lot Closing	-	-	91,855	91,855
Interest	43,000	10,750	11,411	661
Total Revenues	\$ 770,675	\$ 10,750	\$ 103,266	\$ 92,516
Expenditures:				
Series 2023				
Interest - 11/01	\$ 291,375	\$ 291,375	\$ 291,375	\$ -
Principal - 05/01	145,000	-	-	-
Interest - 05/01	291,375	-	-	-
Total Expenditures	\$ 727,750	\$ 291,375	\$ 291,375	\$ -
Excess Revenues (Expenditures)	\$ 42,925		\$ (188,109)	
Fund Balance - Beginning	\$ 358,065		\$ 1,026,629	
Fund Balance - Ending	\$ 400,990		\$ 838,520	

Six Mile Creek

Community Development District

Debt Service Fund - Series 2024

Statement of Revenues, Expenditures, and Changes in Fund Balance For The Period Ending December 31, 2024

	Adopted		Prorated Budget		Actual		Variance
	Budget		Thru 12/31/24		Thru 12/31/24		
Revenues:							
Bond Proceeds	\$	-	\$	-	\$ 359,476	\$	359,476
Interest		-		-	2,324		2,324
Total Revenues	\$	-	\$	-	\$ 361,800	\$	361,800
Expenditures:							
Series 2024							
Interest - 11/01	\$	-	\$	-	-	\$	-
Principal - 05/01		-		-	-		-
Interest - 05/01		-		-	-		-
Total Expenditures	\$	-	\$	-	\$ -	\$	-
Excess Revenues (Expenditures)	\$	-			\$ 361,800		
Fund Balance - Beginning	\$	-			\$ -		
Fund Balance - Ending	\$	-			\$ 361,800		

Six Mile Creek
Community Development District
Developer Contributions/Due to Developer

Funding Request #	Prepare Date	Check#	Received Date	Payment Amount	Total Funding Request	Capital 2017 (Due to Developer)	Capital 2020 (Due to Developer)	Capital 2021 PH1 (Due to Developer)	Capital 2021 PH2 & 3B (Due to Developer)	Capital 2023 AA2 PH3C & AA3 PH3 (Due to Developer)	Capital 2024 (Due to Developer)	Over and (short) Balance Due
10-2021 AA2 PH3B	10/29/24	WIRE	11/19/24	\$1,415.00	\$1,415.00	\$0.00	\$0.00	\$0.00	\$1,415.00	\$0.00	\$0.00	\$0.00 **
1-2023 AA2 PH3C	10/29/24	WIRE	11/19/24	\$526,475.33	\$526,475.33	\$0.00	\$0.00	\$0.00	\$0.00	\$526,475.33	\$0.00	\$0.00 **
1-2023 AA3 PH3	10/29/24	WIRE	11/19/24	\$101,473.72	\$101,473.72	\$0.00	\$0.00	\$0.00	\$0.00	\$101,473.72	\$0.00	\$0.00 **
11-2021 AA3 PH2	12/16/24	WIRE	1/27/25	\$540.50	\$540.50	\$0.00	\$0.00	\$0.00	\$540.50	\$0.00	\$0.00	\$0.00 **
1-2021 AA2 PH3B	12/16/24	WIRE	1/27/25	\$1,471.00	\$1,471.00	\$0.00	\$0.00	\$0.00	\$1,471.00	\$0.00	\$0.00	\$0.00
2-2023 AA2 PH3C	12/16/24	WIRE	1/27/25	\$73,440.99	\$73,440.99	\$0.00	\$0.00	\$0.00	\$0.00	\$73,440.99	\$0.00	\$0.00
2-2023 AA3 PH3	12/16/24	WIRE	1/27/25	\$119,449.65	\$119,449.65	\$0.00	\$0.00	\$0.00	\$0.00	\$119,449.65	\$0.00	\$0.00
1-2024	12/16/24	WIRE	1/27/25	\$484,596.70	\$484,596.70	\$0.00	\$0.00	\$0.00	\$0.00	\$0.00	\$484,596.70	\$0.00
3-2023 AA2 PH3C	12/31/24			\$26,657.05	\$26,657.05	\$0.00	\$0.00	\$0.00	\$0.00	\$26,657.05	\$0.00	(\$26,657.05)
3-2023 AA3 PH3	12/31/24			\$119,379.11	\$119,379.11	\$0.00	\$0.00	\$0.00	\$0.00	\$119,379.11	\$0.00	(\$119,379.11) **
1-2021 AA3 PH1	1/22/25			\$1,378.00	\$1,378.00	\$0.00	\$0.00	\$1,378.00	\$0.00	\$0.00	\$0.00	(\$1,378.00) **
1-2021 AA3 PH2	1/22/25			\$866.00	\$866.00	\$0.00	\$0.00	\$0.00	\$866.00	\$0.00	\$0.00	(\$866.00)
2-2021 AA2 PH3B	1/22/25			\$726.71	\$726.71	\$0.00	\$0.00	\$0.00	\$726.71	\$0.00	\$0.00	(\$726.71)
4-2023 AA2 PH3C	1/22/25	WIRE	1/27/25	\$35,978.58	\$35,978.58	\$0.00	\$0.00	\$0.00	\$0.00	\$35,978.58	\$0.00	\$0.00
4-2023 AA3 PH3	1/22/25	WIRE	1/27/25	\$9,141.90	\$9,141.90	\$0.00	\$0.00	\$0.00	\$0.00	\$9,141.90	\$0.00	\$0.00
2-2024	1/22/25			\$35,696.98	\$35,696.98	\$0.00	\$0.00	\$0.00	\$0.00	\$0.00	\$35,696.98	(\$35,696.98) ***
Due to Developer				\$1,353,983.37	\$1,538,687.22	\$0.00	\$0.00	\$1,378.00	\$5,019.21	\$1,011,996.33	\$520,293.68	(\$184,703.85)

* Chart does not reflect funding requests prior to 10/1/24

** Contains FY24 expenses

***Contains partial FY24 expense

Six Mile Creek

Community Development District Capital Projects Fund - Series 2007

Statement of Revenues, Expenditures, and Changes in Fund Balance For The Period Ending December 31, 2024

	Adopted		Prorated Budget		Actual		Variance
	Budget		Thru 12/31/24		Thru 12/31/24		
Revenues:							
Interest	\$	-	\$	-	\$	28	\$ 28
Total Revenues	\$	-	\$	-	\$	28	\$ 28
Expenditures:							
Series 2007							
Capital Outlay	\$	-	\$	-	\$	-	\$ -
Total Expenditures	\$	-	\$	-	\$	-	\$ -
Excess Revenues (Expenditures)	\$	-			\$	28	
Fund Balance - Beginning	\$	-			\$	2,376	
Fund Balance - Ending	\$	-			\$	2,405	

Six Mile Creek

Community Development District

Capital Projects Fund - Series 2016A

Statement of Revenues, Expenditures, and Changes in Fund Balance For The Period Ending December 31, 2024

	Adopted		Prorated Budget		Actual		Variance
	Budget		Thru 12/31/24		Thru 12/31/24		
Revenues:							
Miscellaneous Income	\$	-	\$	-	\$	50,411	\$ 50,411
Interest		-		-		192	192
Total Revenues	\$	-	\$	-	\$	50,603	\$ 50,603
Expenditures:							
Series 2016A							
Capital Outlay	\$	-	\$	-	\$	-	\$ -
Total Expenditures	\$	-	\$	-	\$	-	\$ -
Excess Revenues (Expenditures)	\$	-			\$	50,603	
Fund Balance - Beginning	\$	-			\$	3,205	
Fund Balance - Ending	\$	-			\$	53,808	

Six Mile Creek

Community Development District

Capital Projects Fund - Series 2016B

Statement of Revenues, Expenditures, and Changes in Fund Balance For The Period Ending December 31, 2024

	Adopted Budget	Prorated Budget Thru 12/31/24	Actual Thru 12/31/24	Variance
Revenues:				
Interest	\$ -	\$ -	\$ 0	\$ 0
Total Revenues	\$ -	\$ -	\$ 0	\$ 0
Expenditures:				
Series 2016B				
Capital Outlay	\$ -	\$ -	\$ -	\$ -
Total Expenditures	\$ -	\$ -	\$ -	\$ -
Excess Revenues (Expenditures)	\$ -		\$ 0	
Fund Balance - Beginning	\$ -		\$ 4	
Fund Balance - Ending	\$ -		\$ 4	

Six Mile Creek

Community Development District

Capital Projects Fund - Series 2017A

Statement of Revenues, Expenditures, and Changes in Fund Balance For The Period Ending December 31, 2024

	Adopted Budget	Prorated Budget Thru 12/31/24	Actual Thru 12/31/24	Variance
Revenues:				
Interest	\$ -	\$ -	\$ 12	\$ 12
Total Revenues	\$ -	\$ -	\$ 12	\$ 12
Expenditures:				
Series 2017A				
Capital Outlay	\$ -	\$ -	\$ -	\$ -
Total Expenditures	\$ -	\$ -	\$ -	\$ -
Excess Revenues (Expenditures)	\$ -	\$ -	\$ 12	
Fund Balance - Beginning	\$ -		\$ 2,941	
Fund Balance - Ending	\$ -		\$ 2,953	

Six Mile Creek

Community Development District Capital Projects Fund - Series 2020

Statement of Revenues, Expenditures, and Changes in Fund Balance For The Period Ending December 31, 2024

	Adopted		Prorated Budget		Actual		Variance
	Budget		Thru 12/31/24		Thru 12/31/24		
Revenues:							
Developer Contributions	\$	-	\$	-	\$	-	\$ -
Interest		-		-	582		582
Total Revenues	\$	-	\$	-	\$ 582		\$ 582
Expenditures:							
Series 2020							
Capital Outlay	\$	-	\$	-	\$ 206,094		\$ (206,094)
Total Expenditures	\$	-	\$	-	\$ 206,094		\$ (206,094)
Other Sources/(Uses)							
Transfer In/(Out)	\$	-	\$	-	\$ 205,300		\$ (205,300)
Total Other Financing Sources (Uses)	\$	-	\$	-	\$ 205,300		\$ (205,300)
Excess Revenues (Expenditures)	\$	-			\$ (212)		
Fund Balance - Beginning	\$	-			\$ 212		
Fund Balance - Ending	\$	-			\$ 0		

Six Mile Creek

Community Development District

Capital Projects Fund - Series 2021 AA3 PH1

Statement of Revenues, Expenditures, and Changes in Fund Balance For The Period Ending December 31, 2024

	Adopted Budget	Prorated Budget Thru 12/31/24	Actual Thru 12/31/24	Variance
Revenues:				
Interest	\$ -	\$ -	\$ 244	\$ 244
Total Revenues	\$ -	\$ -	\$ 244	\$ 244
Expenditures:				
Series 2021 AA3 PH1				
Capital Outlay	\$ -	\$ -	\$ 283,061	\$ (283,061)
Total Expenditures	\$ -	\$ -	\$ 283,061	\$ (283,061)
Other Sources/(Uses)				
Transfer In/(Out)	\$ -	\$ -	\$ 282,613	\$ (282,613)
Total Other Financing Sources (Uses)	\$ -	\$ -	\$ 282,613	\$ (282,613)
Excess Revenues (Expenditures)	\$ -	\$ -	\$ (204)	
Fund Balance - Beginning	\$ -		\$ 204	
Fund Balance - Ending	\$ -		\$ 0	

Six Mile Creek

Community Development District

Capital Projects Fund - Series 2021 AA3 PH2

Statement of Revenues, Expenditures, and Changes in Fund Balance For The Period Ending December 31, 2024

	Adopted		Prorated Budget		Actual		Variance
	Budget		Thru 12/31/24		Thru 12/31/24		
Revenues:							
Developer Contributions	\$	-	\$	-	\$	866	\$ 866
Interest		-		-		7	7
Total Revenues	\$	-	\$	-	\$	873	\$ 873
Expenditures:							
Series 2021 AA3 PH2							
Capital Outlay	\$	-	\$	-	\$	866	\$ (866)
Total Expenditures	\$	-	\$	-	\$	866	\$ (866)
Excess Revenues (Expenditures)	\$	-			\$	7	
Fund Balance - Beginning	\$	-			\$	(229,943)	
Fund Balance - Ending	\$	-			\$	(229,936)	

Six Mile Creek

Community Development District

Capital Projects Fund - Series 2021 AA2 PH3B

Statement of Revenues, Expenditures, and Changes in Fund Balance For The Period Ending December 31, 2024

	Adopted Budget	Prorated Budget Thru 12/31/24	Actual Thru 12/31/24	Variance
Revenues:				
Developer Contributions	\$ -	\$ -	\$ 2,198	\$ 2,198
Interest	-	-	0	0
Total Revenues	\$ -	\$ -	\$ 2,198	\$ 2,198
Expenditures:				
Series 2021 AA2 PH3B				
Capital Outlay	\$ -	\$ -	\$ 232,635	\$ (232,635)
Total Expenditures	\$ -	\$ -	\$ 232,635	\$ (232,635)
Other Sources/(Uses)				
Transfer In/(Out)	\$ -	\$ -	\$ 230,438	\$ (230,438)
Total Other Financing Sources (Uses)	\$ -	\$ -	\$ 230,438	\$ (230,438)
Excess Revenues (Expenditures)	\$ -	\$ -	\$ 0	
Fund Balance - Beginning	\$ -		\$ (498,587)	
Fund Balance - Ending	\$ -		\$ (498,587)	

Six Mile Creek

Community Development District Capital Projects Fund - Series 2023

Statement of Revenues, Expenditures, and Changes in Fund Balance For The Period Ending December 31, 2024

	Adopted Budget	Prorated Budget Thru 12/31/24	Actual Thru 12/31/24	Variance
Revenues:				
Developer Contributions	\$ -	\$ -	\$ 956,931	\$ 956,931
Interest	-	-	7	7
Total Revenues	\$ -	\$ -	\$ 956,938	\$ 956,938
Expenditures:				
Series 2023				
Capital Outlay - AA2 PH3C	\$ -	\$ -	\$ 652,716	\$ (652,716)
Capital Outlay - AA3 PH3	-	-	304,216	(304,216)
Total Expenditures	\$ -	\$ -	\$ 956,931	\$ (956,931)
Other Sources/(Uses)				
Transfer In/(Out)	\$ -	\$ -	\$ -	\$ -
Total Other Financing Sources (Uses)	\$ -	\$ -	\$ -	\$ -
Excess Revenues (Expenditures)	\$ -	\$ -	\$ 7	
Fund Balance - Beginning	\$ -		\$ (372,820)	
Fund Balance - Ending	\$ -		\$ (372,813)	

Six Mile Creek

Community Development District Capital Projects Fund - Series 2024

Statement of Revenues, Expenditures, and Changes in Fund Balance For The Period Ending December 31, 2024

	Adopted Budget	Prorated Budget Thru 12/31/24	Actual Thru 12/31/24	Variance
Revenues:				
Bond Proceeds	\$ -	\$ -	\$ 5,430,524	\$ 5,430,524
Developer Contributions	-	-	494,534	494,534
Interest	-	-	14,507	14,507
Total Revenues	\$ -	\$ -	\$ 5,939,565	\$ 5,939,565
Expenditures:				
Series 2024				
Capital Outlay	\$ -	\$ -	\$ 1,255,385	\$ (1,255,385)
Capital Outlay - Cost of Issuance	-	-	320,748	(320,748)
Total Expenditures	\$ -	\$ -	\$ 1,576,133	\$ (1,576,133)
Other Sources/(Uses)				
Transfer In/(Out)	\$ -	\$ -	\$ -	\$ -
Total Other Financing Sources (Uses)	\$ -	\$ -	\$ -	\$ -
Excess Revenues (Expenditures)	\$ -	\$ -	\$ 4,363,432	
Fund Balance - Beginning	\$ -		\$ (4,399,087)	
Fund Balance - Ending	\$ -		\$ (35,655)	

**Six Mile Creek
Community Development District**

Capital Improvement Revenue Bonds, Series 2016A

Date	Requisition #	Contractor	Description	Requisition
Fiscal Year 2025				
TOTAL				\$ -
Fiscal Year 2025				
10/1/24		Interest		\$ 3.35
11/1/24		Interest		0.05
11/1/24		St. Johns Cty Board Commissioners	Check #626645 Utility Reimbursement	50,411.36
12/2/24		Interest		188.23
TOTAL				\$ 50,602.99
Acquisition/Construction Fund at 9/30/24				\$ 7.91
Interest Earned thru 12/31/24				50,602.99
Requisitions Paid thru 12/31/24				-
Remaining Acquisition/Construction Fund				\$ 50,610.90

**Six Mile Creek
Community Development District**

Capital Improvement Revenue Bonds, Series 2016B

Date	Requisition #	Contractor	Description	Requisition
Fiscal Year 2025				
TOTAL				\$ -
Fiscal Year 2025				
10/2/24		Interest		\$ 0.02
11/1/24		Interest		0.02
12/2/24		Interest		0.01
TOTAL				\$ 0.05
			Acquisition/Construction Fund at 9/30/24	\$ 3.81
			Interest Earned thru 12/31/24	0.05
			Requisitions Paid thru 12/31/24	-
			Remaining Acquisition/Construction Fund	\$ 3.86

**Six Mile Creek
Community Development District**

Capital Improvement Revenue Bonds, Series 2017A

Date	Requisition #	Contractor	Description	Requisition
Fiscal Year 2025				
TOTAL				\$ -
Fiscal Year 2025				
10/2/24		Interest		\$ -
11/1/24		Interest		-
12/2/24		Interest		-
TOTAL				\$ -
			Acquisition/Construction Fund at 9/30/24	\$ 0.23
			Interest Earned thru 12/31/24	-
			Requisitions Paid thru 12/31/24	-
			Remaining Acquisition/Construction Fund	\$ 0.23

**Six Mile Creek
Community Development District**

Capital Improvement Revenue Bonds, Series 2017NW

Date	Requisition #	Contractor	Description	Requisition
Fiscal Year 2025				
TOTAL				\$ -
Fiscal Year 2025				
10/1/24		Interest		\$ 4.07
11/1/24		Interest		3.97
12/2/24		Interest		3.71
TOTAL				\$ 11.75
			Acquisition/Construction Fund at 9/30/24	\$ 984.63
			Interest Earned thru 12/31/24	11.75
			Requisitions Paid thru 12/31/24	-
			Remaining Acquisition/Construction Fund	\$ 996.38

**Six Mile Creek
Community Development District**

Capital Improvement Revenue and Refunding Bonds, Series 2020

Date	Requisition #	Contractor	Description	Requisition
Fiscal Year 2025				
12/20/24	171	Six Mile Investment Group, LLC	Reimbursement for Deficit Funding	\$ 206,093.51
TOTAL				\$ 206,093.51
Fiscal Year 2025				
10/2/24		Interest		\$ 0.88
11/1/24		Interest		0.85
11/27/24		Transfer from Reserve		205,300.00
12/2/24		Interest		101.67
12/20/24		Interest		478.49
TOTAL				\$ 205,881.89
Acquisition/Construction Fund at 9/30/24				\$ 211.62
Interest Earned thru 12/31/24				205,881.89
Requisitions Paid thru 12/31/24				(206,093.51)
Remaining Acquisition/Construction Fund				\$ -

**Six Mile Creek
Community Development District**

Capital Improvement Revenue Bonds, Series 2021 AA3 PH1

Date	Requisition #	Contractor	Description	Requisition
Fiscal Year 2025				
12/20/24	201	Six Mile Investment Group, LLC	Reimbursement for Deficit Funding	\$ 283,060.56
TOTAL				\$ 283,060.56
Fiscal Year 2025				
10/1/24		Interest		\$ 0.84
11/1/24		Interest		0.82
12/2/24		Interest		0.77
12/13/24		Transfer from Reserve		282,612.50
12/20/24		Interest		241.57
TOTAL				\$ 282,856.50
Acquisition/Construction Fund at 9/30/24				\$ 204.06
Interest Earned thru 12/31/24				282,856.50
Requisitions Paid thru 12/31/24				(283,060.56)
Remaining Acquisition/Construction Fund				\$ -

**Six Mile Creek
Community Development District**

Capital Improvement Revenue Bonds, Series 2021 AA3 PH2

Date	Requisition #	Contractor	Description	Requisition
Fiscal Year 2025				
10/15/24	90	Kutak Rock, LLP	Invoice #3453279-18323-2 - Project Construction - July 2024	\$ 164.50
TOTAL				\$ 164.50
Fiscal Year 2025				
10/2/24		Interest		\$ 2.34
10/15/24		Wire	SMCIG FY24 Funding Request #10-2021	164.50
11/1/24		Interest		2.29
12/2/24		Interest		2.13
TOTAL				\$ 171.26
Acquisition/Construction Fund at 9/30/24				\$ 566.50
Interest Earned thru 12/31/24				171.26
Requisitions Paid thru 12/31/24				(164.50)
Remaining Acquisition/Construction Fund				\$ 573.26

**Six Mile Creek
Community Development District**

Capital Improvement Revenue Bonds, Series 2021 AA2 PH3B

Date	Requisition #	Contractor	Description	Requisition
Fiscal Year 2025				
11/19/24	171	England-Thims & Miller	Invoice #215971 - Master Site Planning (WA#51) - Sept.24	\$ 1,415.00
12/20/24	174	Six Mile Investment Group, LLC	Reimbursement for Deficit Funding	\$ 230,437.50
TOTAL				\$ 231,852.50
Fiscal Year 2025				
10/2/24		Interest		\$ 0.02
11/1/24		Interest		0.02
11/19/24		Wire	SMCIG FY24 Funding Request #10-2021	1,415.00
12/2/24		Interest		0.02
12/13/24		Transfer from Reserve		230,437.50
TOTAL				\$ 231,852.56
Acquisition/Construction Fund at 9/30/24				\$ 5.23
Interest Earned thru 12/31/24				231,852.56
Requisitions Paid thru 12/31/24				(231,852.50)
Remaining Acquisition/Construction Fund				\$ 5.29

**Six Mile Creek
Community Development District**

Capital Improvement Revenue Bonds, Series 2023 AA2 PH3C

Date	Requisition #	Contractor	Description	Requisition
Fiscal Year 2025				
10/15/24	83	Jax Utilities Management	Application #16 - Trailmark East Parcel Phase 3 - Aug.24	\$ 1,330,220.88
10/15/24	84	England-Thims & Miller, Inc.	Invoice #215457 - Trailarmk East Parcel PH3 CEI (WA#73) - Aug.24	8,662.25
10/15/24	85	American Precast Structures, LLC	Invs #9448/9449/9780 - Direct Purchase of Materials - Jun/Jul.24	16,740.00
10/15/24	86	ECS Florida, LLC	Invoice #1203027 - Pacetti Road Mast Arm Geotechnical Services - Aug.24	500.00
10/15/24	87	Ferguson Enterprises, LLC	Invs #2097383/2104356/2104462 - Direct Purchase of Materials - Jul/Aug.24	24,396.00
10/15/24	88	Jax Utilities Management	Application #17 - Trailmark East Parcel Phase 3 - Sept.24	286,391.75
11/19/24	89	England-Thims & Miller, Inc.	Invoice #215977 - Trailarmk East Parcel PH3 CEI (WA#73) - Sept.24	9,836.40
11/19/24	90	Ferguson Enterprises, LLC	Invs #2116359 - Direct Purchase of Materials - Oct.24	391.00
11/19/24	91	Jax Utilities Management	Application #18 - Trailmark East Parcel Phase 3 - Oct.24	516,247.93
TOTAL				\$ 2,193,386.21
Fiscal Year 2025				
10/2/24		Interest		\$ 2.35
10/15/24		Wire	SMCIG FY24 Funding Request #6-2023 AA2 PH3C	1,356,123.13
10/15/24		Wire	SMCIG FY24 Funding Request #7-2023 AA2 PH3C	310,787.75
11/1/24		Interest		2.30
11/19/24		Wire	SMCIG FY25 Funding Request #1-2023 AA2 PH3C	526,475.33
12/2/24		Interest		2.14
TOTAL				\$ 2,193,393.00
Acquisition/Construction Fund at 9/30/24				\$ 569.16
Interest Earned thru 12/31/24				2,193,393.00
Requisitions Paid thru 12/31/24				(2,193,386.21)
Remaining Acquisition/Construction Fund				\$ 575.95

**Six Mile Creek
Community Development District**

Capital Improvement Revenue Bonds, Series 2023 AA3 PH3

Date	Requisition #	Contractor	Description	Requisition
Fiscal Year 2025				
10/15/24	72A	Onsight Industries, LLC	Invoice #416216 - Trailmark Phase 12 Mailboxes - Jul.24	\$ 1,450.00
10/15/24	73A	Jax Utilities Management, Inc.	Application #18 - Trailmark Phase 12 - Aug.24	52,454.25
10/15/24	74A	England-Thims & Miller, Inc.	Invoice #215490 - Trailmark Phase 12 CEI (WA#70) - Aug.24	15,530.66
10/15/24	75A	Tree Amigos Outdoor Services, Inc.	Application #2 - Trailmark Phase 12 Lift Station - Sept.24	6,152.00
10/15/24	76A	England-Thims & Miller, Inc.	Inv #215525 - Trailmark Dr at Pacetti Rd - Traffic Signal Design (WA#79) - Aug.24	10,720.00
10/15/24	77A	Jax Utilities Management, Inc.	Application #19 - Trailmark Phase 12 - Sept.24	30,255.60
10/15/24	78A	BrightView Landscape Services, Inc.	Invoice #9096206 - Trailmark Dr Landscape Services - Sept.24	6,043.55
11/19/24	79A	England-Thims & Miller, Inc.	Invoices #215989 & 216007 - Trailmark Phase 12 (WA#70 & WA#79) - Sept.24	28,475.72
11/19/24	80A	Jax Utilities Management, Inc.	Application #20 - Trailmark Phase 12 - Oct.24	72,998.00
TOTAL				\$ 224,079.78
Fiscal Year 2025				
10/2/24		Interest		\$ 0.02
10/15/24		Wire	SMCIG FY24 Funding Request #13-2023 AA2 PH3C	69,434.91
10/15/24		Wire	SMCIG FY24 Funding Request #14-2023 AA2 PH3C	53,171.15
11/1/24		Interest		0.02
11/19/24		Wire	SMCIG FY25 Funding Request #1-2023 AA2 PH3C	101,473.72
12/2/24		Interest		0.02
TOTAL				\$ 224,079.84
Acquisition/Construction Fund at 9/30/24				\$ 4.85
Interest Earned thru 12/31/24				224,079.84
Requisitions Paid thru 12/31/24				(224,079.78)
Remaining Acquisition/Construction Fund				\$ 4.91

**Six Mile Creek
Community Development District**

Capital Improvement Revenue Bonds, Series 2024

Date	Requisition #	Contractor	Description	Requisition
Fiscal Year 2025				
10/31/24	1	Six Mile Creek Investment Group	Reimbursement of JUM Application Payments	\$ 2,541,725.76
10/31/24	2	Onsight Industries, LLC	Invoice #421873 - Trailmark Mailboxes - Oct.24	1,775.00
10/31/24	3	Onsight Industries, LLC	Invoice #42005 - Trailmark Street Signage - Sept.24	5,111.60
10/31/24	4	Tree Amigos Outdoor Services	Invoice #202712 - Trailmark Landscaping Services - Sept.24	21,750.00
10/31/24	5	BrightView Landscape Services, Inc.	Invoice #9091313 - Goldenrod Enhancements A1-A7 - Sept.24	79,324.21
10/31/24	6	Clary & Associates	Invoice #2024-428 - Phase 13 Maps & Descriptions - Jul.24	1,500.00
10/31/24	7	England-Thims & Miller, Inc.	Invs #215456 & 215976 - Phase 13 CEI - Aug/Sept.24	14,795.17
10/31/24	8	Jax Utilities Management, Inc.	Applications #7 & 8 - Trailmark Phase 13 - Aug/Sept.24	1,887,070.64
11/7/24	9	Jax Utilities Management, Inc.	Applications #9 - Trailmark Phase 13 - Oct.24	529,098.48
12/18/24	10	England-Thims & Miller, Inc.	Invoice #216452 - Phase 13 CEI (WA#80) - Oct.24	9,268.47
12/18/24	11	Ferguson Enterprises, LLC	Direct Purchases>Returns of Materials	4,466.60
12/18/24	12	Jax Utilities Management, Inc.	Application #10 - Trailmark Phase 13 (Partial Payment) - Nov.24	192,825.42
TOTAL				\$ 5,288,711.35
Fiscal Year 2025				
11/1/24		Interest		\$ 13,323.82
11/1/24		Deposit	Richmond American Homes - Reimbursement	138,773.00
11/1/24		Deposit	Carlton Constructon - Reimbursement	25,760.00
12/2/24		Interest		1,178.36
TOTAL				\$ 179,035.18
Acquisition/Construction Fund at 10/11/24				\$ 5,109,676.17
Interest Earned thru 11/30/24				179,035.18
Requisitions Paid thru 11/30/24				(5,288,711.35)
Remaining Acquisition/Construction Fund				\$ -

E.

F.

Six Mile Creek Community Development District

Summary of Invoices

January 01, 2025 - January 31, 2025

Fund	Date	Check No.'s	Amount
General Fund			
	1/6/25	534-543	\$ 50,401.33
	1/7/25	544-545	8,103.85
	1/14/25	546-550	7,934.03
	1/23/25	551-559	73,271.41
	1/28/25	560-568	729,230.43
			\$ 868,941.05
Reverie Fund			
	1/7/25	315-328	\$ 53,286.29
	1/14/25	329-335	6,566.32
	1/23/25	336-345	29,152.31
	1/28/25	346-350	8,851.68
			\$ 97,856.60
Payroll			
	<u>January 2025</u>		
	Heather S. Brofford	50237	\$ 184.70
	Jacob T. Dunn	50238	184.70
	Michelle M. Sutton	50239	184.70
	Mindy R. Gellman	50240	184.70
	Wendy S. Hartley	50241	184.70
			\$ 923.50
TOTAL			\$ 967,721.15

CHECK DATE	VEND#INVOICE..... DATE INVOICE	...EXPENSED TO... YRMO DPT ACCT# SUB SUBCLASS	VENDOR NAME	STATUS	AMOUNTCHECK..... AMOUNT #	
1/06/25	00118	1/01/25 72934079	202501 330-53800-46800	LAWN CARE SERVICE JAN25	*	296.55		
							RENTOKIL NORTH AMERICA INC	296.55 000534
1/06/25	00170	12/26/24 9195131	202412 320-53800-46600	CUT/PUT BACK 5 SPLIT OAK	*	1,690.14		
		12/26/24 9195324	202412 320-53800-46200	MTHLY MAINTENANCE DEC24	*	30,583.28		
		12/30/24 9197515	202412 320-53800-46201	WINTER FLOWERS INST/SOIL	*	2,175.52		
							BRIGHTVIEW LANDSCAPE SERVICES, INC.	34,448.94 000535
1/06/25	00237	12/25/24 2817	202501 330-53800-46500	MTHLY POOL SERVICE JAN25	*	1,800.00		
		12/25/24 2817A	202412 330-53800-46501	36LB OF BICARB	*	45.00		
							C BUSS ENTERPRISES INC	1,845.00 000536
1/06/25	00252	12/30/24 236360	202412 330-53800-46000	SVC CALL-CLN OUT DRAIN LN	*	380.00		
							CRABTREE PLUMBING INC	380.00 000537
1/06/25	00001	1/01/25 192	202501 310-51300-34000	MANAGEMENT FEES JAN25	*	3,750.00		
		1/01/25 192	202501 310-51300-35200	WEBSITE ADMIN JAN25	*	105.00		
		1/01/25 192	202501 310-51300-35100	INFORMATION TECH JAN25	*	157.50		
		1/01/25 192	202501 310-51300-31300	DISSEMINATION FEE JAN24	*	1,143.33		
		1/01/25 192	202501 310-51300-51000	OFFICE SUPPLIES	*	2.53		
		1/01/25 192	202501 310-51300-42000	POSTAGE	*	134.37		
		1/01/25 192	202501 310-51300-42500	COPIES	*	135.45		
		1/01/25 192	202501 310-51300-41000	TELEPHONE	*	118.42		
							GOVERNMENTAL MANAGEMENT SERVICES	5,546.60 000538
1/06/25	00152	12/06/24 92528669	202412 310-51300-49100	MICHELLE SUTTON-DESK SIGN	*	14.99		
		12/06/24 92528669	202412 310-51300-49100	HEATHER BROFFORD-DESK SGN	*	14.99		
		12/06/24 92528669	202412 310-51300-49100	MINDY GELLMAN-DESK SIGN	*	14.99		
							SIXM SIX MILE CREEK TVISCARRA	

CHECK DATE	VEND#	INVOICE DATE	INVOICE	EXPENSED TO... YRMO	DPT ACCT#	SUB SUBCLASS	VENDOR NAME	STATUS	AMOUNT	CHECK AMOUNT	CHECK #
12/06/24		92528669	202412	310-51300-49100			JACOB DUNN-DESK SIGN	*	14.99		
12/06/24		92528669	202412	310-51300-49100			SHIPPING & HANDLING-GRND	*	9.99		
										69.95	000539
1/06/25	00031	1/01/25	619389	202501	310-51700-71000		FITNESS LEASE PAYMENT#24	*	2,423.48		
		1/01/25	619389	202501	310-51700-72000		FITNESS LEASE PAYMENT#24	*	435.86		
										2,859.34	000540
1/06/25	00039	1/01/25	9415-B	202501	320-53800-46400		MTHLY LAKE MAINT JAN25	*	4,220.00		
										4,220.00	000541
1/06/25	00084	1/01/25	24-58550	202501	320-53800-34600		MTHLY FIRE ALARM MNTR JAN	*	34.95		
										34.95	000542
1/06/25	00128	12/18/24	24-01501	202412	330-53800-46501		PM MAINT INSP-LAP/LAGOON	*	700.00		
										700.00	000543
1/07/25	00022	11/27/24	217104	202411	310-51300-31100		GEN CONSLT ENG SVC(WA#82)	*	2,171.50		
		1/03/25	217508	202412	310-51300-31100		GEN CONSLT ENG SVC(WA#82)	*	3,235.50		
										5,407.00	000544
1/07/25	00024	12/19/24	556887-1	202412	330-53800-43100		805 TRAILMARK DR - DEC24	*	2,658.25		
		12/19/24	556887-1	202412	330-53800-43100		295 BACK CREEK DR - DEC24	*	38.60		
										2,696.85	000545
1/14/25	00162	1/01/25	2501-TSM	202501	320-53800-47700		PET STATION MAINT JAN25	*	206.00		
										206.00	000546
1/14/25	00235	12/31/24	6884751	202412	310-51300-48000		NOT.OF MEETING 01/08/25	*	65.92		
										65.92	000547
1/14/25	00263	1/08/25	01082024	202501	320-53800-47200		TRIVIA NIGHT - 01/24/25	*	200.00		
										200.00	000548

SIXM SIX MILE CREEK TVISCARRA

CHECK DATE	VEND#	INVOICE DATE	INVOICE	EXPENSED TO YRMO	DPT	ACCT#	SUB	SUBCLASS	VENDOR NAME	STATUS	AMOUNT	CHECK AMOUNT	CHECK #
1/14/25	00098	1/10/25	5502JAN2	202501	310	51300	45000		BANQUET SERVICE CHR 1/08	*	188.98		
									RENAISSANCE WORLD GOLF VILLAGE			188.98	000549
1/14/25	00021	12/24/24	7589535	202412	310	51300	32300		TRUSTEE FEES-SER.2021	*	7,273.13		
									US BANK			7,273.13	000550
1/23/25	00170	1/01/25	9212569	202501	320	53800	46200		MTHLY MAINTENANCE JAN25	*	35,170.83		
		1/20/25	9212084	202501	320	53800	46300		MAINLINE RPR-CLOVERLY PMP	*	762.87		
		1/20/25	9212085	202501	320	53800	46300		RPR DECODE/VLVE/SPLICE/FT	*	3,844.56		
									BRIGHTVIEW LANDSCAPE SERVICES, INC.			39,778.26	000551
1/23/25	00173	1/13/25	1783	202501	320	53800	12300		EVENT MONITOR 01/05-01/25	*	532.19		
									ELITE AMENITIES NE FLORIDA LLC			532.19	000552
1/23/25	00038	1/17/25	1150082E	202412	330	53800	43200		801 TRAILMARK DR - DEC24	*	18.25		
									FLORIDA NATURAL GAS			18.25	000553
1/23/25	00218	1/20/25	6966194	202501	330	53800	46501		2659LB AZONE/648LB S.ACID	*	1,077.42		
									HAWKINS INC			1,077.42	000554
1/23/25	00181	1/14/25	3512048	202410	310	51300	31500		LNDSKP RFP/LIC.AGR/TOW RQ	*	1,787.50		
		1/14/25	3512048A	202411	310	51300	31500		BD MTG/LDSCP AGR/AWARD LT	*	2,501.53		
									KUTAK ROCK LLP			4,289.03	000555
1/23/25	00214	1/15/25	8670	202501	320	53800	46700		JANITORIAL SERVICE JAN25	*	2,945.00		
									KEEN ON KLEAN LLC			2,945.00	000556
1/23/25	00222	1/22/25	1625	202501	320	53800	12200		ONSITE AMENITIES JAN25	*	9,500.00		
		1/22/25	1625	202501	320	53800	12200		ADDITIONAL PAYROLL JAN25	*	236.12		
									ONPLACE LLC			9,736.12	000557
1/23/25	00256	10/15/24	ONSITE-2	202410	320	53800	12100		MTHLY ONSITE 10/01-10/15	*	2,541.00		

SIXM SIX MILE CREEK TVISCARRA

CHECK DATE	VEND#	INVOICE DATE	INVOICE	EXPENSED TO YRMO	DPT	ACCT#	SUB	SUBCLASS	VENDOR NAME	STATUS	AMOUNT	CHECK AMOUNT	CHECK #
10/31/24			ONSITE-2	202410	320	53800	12100			*	2,252.25		
			MTHLY ONSITE	10/16-10/31									
11/15/24			ONSITE-2	202411	320	53800	12100			*	2,994.75		
			MTHLY ONSITE	11/01-11/15									
11/30/24			ONSITE-2	202411	320	53800	12100			*	2,656.50		
			MTHLY ONSITE	11/16-11/30									
12/15/24			ONSITE-2	202412	320	53800	12100			*	2,013.00		
			MTHLY ONSITE	12/01-12/15									
12/31/24			ONSITE-2	202412	320	53800	12100			*	2,392.50		
			MTHLY ONSITE	12/16-12/31									
REALMANAGE LLC											14,850.00	000558	
1/23/25	00245	1/17/25	9683/4	202501	330	53800	46000			*	45.14		
			4 LEDS/2 PULL UTILITIES										
TURNER WGV LLC											45.14	000559	
1/28/25	00170	1/24/25	9217316	202501	320	53800	46600			*	930.52		
			42 PATINA PL-INST.OAKTREE										
BRIGHTVIEW LANDSCAPE SERVICES, INC.											930.52	000560	
1/28/25	00096	1/22/25	22	202501	310	51300	31300			*	250.00		
			REV.AMORT SER2017A	02/01									
		1/22/25	22	202501	310	51300	31300			*	100.00		
			REV.AMORT SER2020	02/01									
		1/22/25	22	202501	310	51300	31300			*	100.00		
			REV.AMORT SER2021	02/01									
DISCLOSURE SERVICES LLC											450.00	000561	
1/28/25	00024	1/19/25	556887-1	202501	330	53800	43100			*	2,891.99		
			805 TRAILMARK DR - JAN25										
		1/19/25	556887-1	202501	330	53800	43100			*	38.60		
			295 BACK CREEK DR JAN25										
ST.JOHNS COUNTY UTILITY DEPT.											2,930.59	000562	
1/28/25	00249	1/28/25	8	202501	300	15500	10000			*	300.00		
			SUPER BOWL PARTY	02/09/25									
GARY A WHITAKER											300.00	000563	
1/28/25	00022	10/30/24	216447	202501	300	13100	10100			*	670.00		
			MASTER SITE PLN(WA#51)OCT										
		10/30/24	216453	202501	300	13100	10100			*	12,522.99		
			TRLMK E PRCL PH3(WA#73)										
		10/31/24	216486	202501	300	13100	10100			*	9,684.65		
			TRAILMARK PH12 CEI(WA#70)										
		11/27/24	217027	202501	300	13100	10100			*	801.00		
			MASTER SITE PLN(WA#51)NOV										

SIXM SIX MILE CREEK TVISCARRA

CHECK DATE	VEND#	INVOICE DATE	INVOICE	EXPENSED TO YRMO	DPT	ACCT#	SUB	SUBCLASS	VENDOR NAME	STATUS	AMOUNT	CHECK AMOUNT	CHECK #
11/27/24		217039	202501 300-13100-10100						PHASE 13 CEI(WA#80)NOV24	*	10,419.50		
11/27/24		217042	202501 300-13100-10100						TRLMRK E PRCL PH3(WA#73)	*	4,259.25		
11/27/24		217112	202501 300-13100-10100						TRAILMARK PHASE 12(WA#70)	*	13,611.50		
12/03/24		217408	202501 300-13100-10100						PACETTI RD-TRAFFIC SIGNAL	*	8,060.00		
1/03/25		217495	202501 300-13100-10100						TRLMRK E PRCL PH3(WA#73)	*	9,778.58		
1/06/25		217515	202501 300-13100-10100						TRAILMARK PH12 CEI(WA#70)	*	2,281.90		
1/07/25		217853	202501 300-13100-10100						TRLMRK DR-PACETTI-TRAFFIC	*	6,860.00		
ENGLAND-THIMS & MILLER, INC											78,949.37	000564	
1/28/25	00174	12/31/24	40770	202501 300-13100-10100					TRLMRK EAST PRCL PH3 HAUL	*	26,200.00		
ENVIRONMENTAL RESOURCE SOLUTIONS											26,200.00	000565	
1/28/25	00241	11/07/24	2122257	202501 300-13100-10100					DIRECT PURCH MATS - NOV24	*	34.00		
FERGUSON WATERWORKS											34.00	000566	
1/28/25	00185	11/25/24	APP#10	202501 300-13100-10100					TRLMK PH13 NOV24(PARTIAL)	*	474,177.20		
		11/25/24	APP#19A	202501 300-13100-10100					TRAILMARK EAST PRCL PH3	*	56,624.75		
		11/25/24	APP#21	202501 300-13100-10100					TRAILMARK PHASE 12-NOV24	*	88,093.50		
JAX UTILITIES MANAGEMENT INC											618,895.45	000567	
1/28/25	00181	11/06/24	3480055	202501 300-13100-10100					PROJ.CONSTRUCTION AUG24	*	188.00		
		12/05/24	3496010	202501 300-13100-10100					PROJ.CONSTRUCTION SEP24	*	352.50		
KUTAK ROCK LLP											540.50	000568	
TOTAL FOR BANK C											868,941.05		
TOTAL FOR REGISTER											868,941.05		

SIXM SIX MILE CREEK TVISCARRA

CHECK DATE	VEND#	INVOICE DATE	INVOICE	EXPENSED YRMO	TO DPT	ACCT#	SUB	SUBCLASS	VENDOR NAME	STATUS	AMOUNT	CHECK AMOUNT	CHECK #
1/07/25	00018	12/17/24	6320	202412	340	53800	46501			*	1,932.84		
			RPLC 3 PH/3 ORP PROBES										
		1/01/25	6334	202501	340	53800	46500			*	2,060.00		
			POOL MAINTENANCE JAN25										
									FSJ POOL SERVICES LLC			3,992.84	000315
1/07/25	00016	12/23/24	45042	202412	340	53800	46000			*	225.00		
			QTRLY FIRE ALARM MNTR DEC										
									DYNAMIC SECURITY PROFESSIONALS INC			225.00	000316
1/07/25	00004	12/02/24	748838	202501	340	53800	34500			*	3,680.61		
			ALARM MONITOR SRVCS JAN25										
		12/11/24	INV00000	202412	340	53800	34500			*	1,005.00		
			100-34 BIT HSF FOB/SHIP										
									HIDDEN EYES LLC DBA ENVERA SYSTEMS			4,685.61	000317
1/07/25	00017	1/02/25	6951189	202501	340	53800	46501			*	870.00		
			3191.1LB AZONE/FUEL SRCHG										
									HAWKINS INC			870.00	000318
1/07/25	00050	1/01/25	JAK01250	202501	340	53800	46700			*	1,399.89		
			JANITORIAL SERVICES JAN25										
									JANI-KING OF JACKSONVILLE			1,399.89	000319
1/07/25	00010	12/27/24	1060	202501	340	53800	47300			*	6,426.97		
			HOLIDAY LIGHTING INST/RMV										
									M&G BUSINESS VENTURES INC DBA			6,426.97	000320
1/07/25	00022	11/11/24	59393820	202411	340	53800	46800			*	75.00		
			MTHLY PEST CONTROL NOV24										
		12/31/24	59406313	202412	340	53800	46800			*	75.00		
			MTHLY PEST CONTROL DEC24										
									MCCALL PEST CONTROL			150.00	000321
1/07/25	99999	1/07/25	VOID	202501	000	00000	00000			C	.00		
			VOID CHECK										
									*****INVALID VENDOR NUMBER*****			.00	000322
1/07/25	00023	12/31/24	1241PR-3	202410	340	53800	12000			*	3,000.40		
			CASSIE PASSANTINO-PAYROLL										
		12/31/24	1311CCR-	202411	340	53800	47200			*	55.00		
			AMAZON-10 AMAZON GIFT CRD										
		12/31/24	1311CCR-	202410	340	53800	47200			*	61.13		
			PUBLIX-BLUETILE/CHINET/BV										
		12/31/24	1311CCR-	202410	340	53800	47200			*	73.96		
			DUNKIN-50MUNCHKIN/2COFFEE										

SIXM SIX MILE CREEK TVISCARRA

CHECK DATE	VEND#INVOICE..... DATE INVOICE	...EXPENSED TO... YRMO DPT ACCT# SUB SUBCLASS	VENDOR NAME	STATUS	AMOUNTCHECK.... AMOUNT #
12/31/24		1311CCR- 202410	340-53800-47200	PUBLIX-FRUIT PLATTER/SKWR	*	149.07	
12/31/24		1311CCR- 202410	340-53800-47200	PUBLIX-PURE LIFE/CHINET	*	71.08	
12/31/24		1311CCR- 202410	340-53800-47200	AMAZON-CHEESECLTH/TBL DCR	*	21.08	
12/31/24		1311CCR- 202410	340-53800-47200	AMAZON-12 AMAZON GIFT CRD	*	90.00	
12/31/24		1311CCR- 202410	340-53800-47200	FAST JAX TRIVIA-10/18/24	*	275.00	
12/31/24		1311CCR- 202410	340-53800-47200	AMAZON-HALLOWEEN BACKDROP	*	22.35	
12/31/24		1311CCR- 202410	340-53800-47200	AMAZON-PUMPKIN DIY/PAINT	*	119.21	
12/31/24		1311CCR- 202410	340-53800-47200	AMAZON-SMOKE MACH/CANDLE	*	546.00	
12/31/24		1311CCR- 202410	340-53800-47200	PUBLIX-PUB SUB/LEMONADE	*	209.26	
12/31/24		1311CCR- 202410	340-53800-47200	MICHAELS-25 CRAFT PUMPKIN	*	106.23	
12/31/24		1311CCR- 202410	340-53800-47200	PARTY CITY-STAND SGN/CURT	*	10.60	
12/31/24		1311CCR- 202410	340-53800-47200	PARTY CITY-HALLOWEEN DECR	*	18.64	
12/31/24		1311CCR- 202410	340-53800-47200	PUBLIX-CLOROX WIPES/P.TWL	*	16.70	
12/31/24		1311CCR- 202410	340-53800-47200	AMAZON-ELECT.BALLOON PUMP	*	15.96	
12/31/24		1311CCR- 202410	340-53800-47200	AMAZON-SKELETON/TBL CLOTH	*	121.36	
12/31/24		1311CCR- 202410	340-53800-47200	AMAZON-CONNECT. ORNG LGHTS	*	14.56	
12/31/24		1311CCR- 202410	340-53800-47200	STAPLES-TICKETS/STPLR/TAP	*	70.87	
12/31/24		1311CCR- 202410	340-53800-47200	PARTY CITY-CAULDRON/PMPKN	*	44.13	
12/31/24		1311CCR- 202410	340-53800-47200	PUBLIX-BROWNIE/COOKIE/ICE	*	122.28	
12/31/24		1311CCR- 202410	340-53800-47200	PUBLIX-VEG.PLATTER/SALAD	*	63.89	
12/31/24		1311CCR- 202410	340-53800-51000	CONSTANT CONTACT OCT24	*	24.50	
12/31/24		1311CCR- 202410	340-53800-49100	10% CREDIT CARD FEE-OCT24	*	232.29	
THE REVERIE HOMEOWNERS' ASSOCIATION						5,555.55	000323

SIXM SIX MILE CREEK TVISCARRA

*** CHECK DATES 01/01/2025 - 01/31/2025 ***
 REVERIE
 BANK D REVERIE FUND

CHECK DATE	VEND#	INVOICE DATE	INVOICE	EXPENSED TO YRMO	DPT	ACCT#	SUB	SUBCLASS	VENDOR NAME	STATUS	AMOUNT	CHECK AMOUNT	CHECK #
1/07/25	00055	11/08/24	683556	202411	320	320-53800	46201		INST.800 BALES PINE STRAW	*	6,200.00		
		11/08/24	683557	202411	320	320-53800	46600		BIER GARDEN-CLN OUT TREE	*	1,450.00		
		11/08/24	683581	202411	320	320-53800	46300		RPR ZONE LINE/SPRAY/NOZZL	*	127.00		
		12/20/24	689409	202412	320	320-53800	46201		2286-1QT ANNUAL FLOWERS	*	6,515.00		
		12/31/24	690446	202412	320	320-53800	46200		LANDSCAPE MAINT DEC24	*	8,114.43		
		12/31/24	690447	202412	340	340-53800	46200		LANDSCAPE AMENITY DEC24	*	2,737.07		
RUPPERT LANDSCAPE LLC											25,143.50	000324	
1/07/25	00005	12/19/24	556887-1	202412	340	340-53800	43100		255 RUSTIC MILL DR-DEC24	*	15.57		
		12/19/24	556887-1	202412	340	340-53800	43100		35 RUSTIC MILL DR - DEC24	*	3,316.08		
ST.JOHNS COUNTY UTILITY DEPT.											3,331.65	000325	
1/07/25	00013	1/01/25	9410-B	202501	320	320-53800	46400		MTHLY LAKE MAINT JAN24	*	1,164.00		
SITEX AQUATICS LLC											1,164.00	000326	
1/07/25	00027	12/31/24	60207532	202412	340	340-53800	51000		STAPLES COPY SELECT 20/94	*	45.71		
		12/31/24	60207532	202412	340	340-53800	51000		HP 414X HY BLACK LJ TNR	*	166.67		
STAPLES											212.38	000327	
1/07/25	00030	12/11/24	9460/4	202412	340	340-53800	46000		GORILLA WOOD GLUE/BATTERY	*	20.97		
		12/12/24	9463/4	202412	340	340-53800	46000		3-FLMN LED A19 SW 9W 4PK	*	53.97		
		12/17/24	9478/4	202412	340	340-53800	47500		2-CABLETIE 8"75#BLK 100PK	*	19.98		
		12/20/24	9506/4	202412	340	340-53800	46900		2-CONTRACTOR BAG 42G 20PK	*	33.98		
TURNER WGV LLC											128.90	000328	
1/14/25	00008	1/06/25	AC01057	202501	340	340-53800	47500		2-EQUIPMNT CLN WIPE-4ROLL	*	358.00		
COMMERCIAL FITNESS PRODUCTS, INC											358.00	000329	
1/14/25	00002	1/01/25	2501-RT	202501	320	320-53800	47700		REV-PET STATION SVC JAN25	*	482.00		
DOODY DADDY											482.00	000330	
SIXM SIX MILE CREEK TVISCARRA													

CHECK DATE	VEND#	INVOICE DATE	INVOICE	YRMO	DPT	ACCT#	SUB	SUBCLASS	VENDOR NAME	STATUS	AMOUNT	CHECK AMOUNT	CHECK #
1/14/25	00004	12/30/24	749657	202412	340	53800	34500		ADDITIONAL RESIDENT DEC24	*	50.00		
		12/30/24	749657A	202501	340	53800	34500		ADDITIONAL RESIDENT JAN25	*	50.00		
		1/02/25	750015	202501	300	15500	10000		ALARM MONITOR SRVCS FEB25	*	3,730.61		
HIDDEN EYES LLC DBA ENVERA SYSTEMS												3,830.61	000331
1/14/25	00065	10/18/24	10182024	202410	340	53800	47200		TRIVIA SHOW 10/18/24	*	275.00		
JOHN HARRELL												275.00	000332
1/14/25	00017	12/18/24	6946004	202412	340	53800	46501		648LB SLFR ACID/40LB DELD	*	278.16		
HAWKINS INC												278.16	000333
1/14/25	00055	12/31/24	690448	202412	320	53800	46200		LANDSCAPE PH2 MAINT DEC24	*	1,307.57		
RUPPERT LANDSCAPE LLC												1,307.57	000334
1/14/25	00030	1/07/25	9609/4	202501	340	53800	47500		LEATHER GLOVE/PTY KNF CRB	*	34.98		
TURNER WGV LLC												34.98	000335
1/23/25	00064	10/18/24	186267	202410	340	53800	46000		REINST.7 SUN SHADES/CLEAN	*	995.00		
ALL WEATHER CONTRACTORS INC												995.00	000336
1/23/25	00065	1/16/25	01102025	202501	340	53800	47200		BINGO FACILITATOR 1/10/25	*	275.00		
		1/16/25	11152024	202411	340	53800	47200		TRIVIA FACILITATOR 11/15	*	275.00		
		1/16/25	12132024	202412	340	53800	47200		TRIVIA FACILITATOR 12/13	*	285.00		
JOHN HARRELL												835.00	000337
1/23/25	00033	1/10/25	02072025	202501	300	15500	10000		MUSICAL BINGO 02/07/25	*	200.00		
GARY A WHITAKER												200.00	000338
1/23/25	00007	1/15/25	619402	202501	310	51700	71000		FITNESS LEASE PAYMENT#25	*	1,944.87		
		1/15/25	619402	202501	310	51700	72000		FITNESS LEASE PAYMENT#25	*	334.02		
MUNICIPAL ASSET MANAGEMENT, INC.												2,278.89	000339

SIXM SIX MILE CREEK TVISCARRA

CHECK DATE	VEND#	INVOICE DATE	INVOICE	EXPENSED TO YRMO	DPT	ACCT#	SUB	SUBCLASS	VENDOR NAME	STATUS	AMOUNT	CHECK AMOUNT	CHECK #
1/23/25	00022	1/09/25	59420321	202501	340	53800	46800		MTHLY PEST CONTROL JAN25	*	75.00		
MCCALL PEST CONTROL												75.00	000340
1/23/25	99999	1/23/25	VOID	202501	000	00000	00000		VOID CHECK	C	.00		
*****INVALID VENDOR NUMBER*****												.00	000341
1/23/25	99999	1/23/25	VOID	202501	000	00000	00000		VOID CHECK	C	.00		
*****INVALID VENDOR NUMBER*****												.00	000342
1/23/25	99999	1/23/25	VOID	202501	000	00000	00000		VOID CHECK	C	.00		
*****INVALID VENDOR NUMBER*****												.00	000343
1/23/25	00023	1/15/25	11026932	202412	320	53800	12200		FIELD OPER 11/30 - 12/13	*	454.62		
1/15/25		11026932	202412	340	53800	12100		ONSITE ADMIN 11/30-12/13	*	2,071.61			
1/15/25		11026932	202412	320	53800	12200		MGMT/ADMIN 11/30 - 12/13	*	2,967.00			
1/16/25		11028635	202412	320	53800	12200		MGMT/ADMIN INSUR DEC24	*	726.00			
1/16/25		1333PR-3	202501	340	53800	12000		PASSANTINO-3 JAN25 PERIOD	*	9,000.00			
1/16/25		1333PR-3	202501	300	15500	10000		PASSANTINO-2 FEB25 PERIOD	*	6,000.00			
1/16/25		1413CCR-	202412	340	53800	47200		HOBBY LOBBY-XMAS ORNAMENT	*	25.53			
1/16/25		1413CCR-	202412	340	53800	47200		PUBLIX-LARGE FRUIT SALAD	*	19.83			
1/16/25		1413CCR-	202412	340	53800	47200		DUNKIN-MUNCHKIN/DONUT/COF	*	112.44			
1/16/25		1413CCR-	202412	340	53800	47200		PARTY CITY-SUPPLY TREE-WS	*	5.07			
1/16/25		1413CCR-	202412	340	53800	47200		AMAZON-10 AMAZON GIFT CRD	*	80.00			
1/16/25		1413CCR-	202412	340	53800	47200		PUBLIX-CHINET/BEV/PLTR/VE	*	94.76			
1/16/25		1413CCR-	202412	340	53800	47200		AMAZON-NAPKIN/PLATES/ARCH	*	143.59			
1/16/25		1413CCR-	202412	340	53800	47200		PUBLIX-CHINET/BEV/HUMMUS	*	146.25			
1/16/25		1413CCR-	202412	340	53800	47200		AMAZON-BALLOON/LED/TBLCLT	*	243.49			

SIXM SIX MILE CREEK TVISCARRA

CHECK DATE	VEND#INVOICE..... DATE INVOICE	...EXPENSED TO... YRMO DPT ACCT# SUB SUBCLASS	VENDOR NAME	STATUS	AMOUNTCHECK..... AMOUNT #
1/16/25		1413CCR- 202412	340-53800-47200	AMAZON-CHAMPAGNE GLASSES	*	108.78	
1/16/25		1413CCR- 202412	340-53800-47200	TARGET-KRAFT/DRNK/MRSHMLW	*	154.59	
1/16/25		1413CCR- 202412	340-53800-47200	WALMART-COTTON BALL/MASK	*	104.42	
1/16/25		1413CCR- 202412	340-53800-54000	CONSTANT CONTACT DEC24	*	35.00	
1/16/25		1413CCR- 202412	340-53800-47200	PARTY CITY-PONG/RING/STRM	*	31.68	
1/16/25		1413CCR- 202412	340-53800-47200	PUBLIX-CREAM/HOT COCOA	*	165.92	
1/16/25		1413CCR- 202412	340-53800-47200	AMAZON-COOKIE BOX	*	36.67	
1/16/25		1413CCR- 202412	340-53800-47200	PUBLIX-CHINET/ZIPLOC/COOK	*	44.47	
1/16/25		1413CCR- 202412	340-53800-47200	PARTY CITY-BSG PARTY KIT	*	125.22	
1/16/25		1413CCR- 202412	340-53800-51000	WALMART-2BAJA/CUSHION	*	72.10	
1/16/25		1413CCR- 202412	340-53800-47200	PUBLIX-CHINET/CUP/NAPKINS	*	190.21	
1/16/25		1413CCR- 202412	340-53800-51000	WALGREENS-2 DUCT TAPE	*	17.02	
1/16/25		1413CCR- 202412	340-53800-47200	HOBBY LOBBY-NEW YEAR DECR	*	44.84	
1/16/25		1413CCR- 202412	340-53800-47200	MICHAELS-NEW YR TABL DECR	*	55.35	
1/16/25		1413CCR- 202412	340-53800-47200	PARTY CITY-PRILLETTE/CLCK	*	54.50	
1/16/25		1413CCR- 202412	340-53800-47200	PUBLIX-POPCORN/CHCKEN/VEG	*	309.34	
1/16/25		1413CCR- 202412	340-53800-47200	DOLLAR TREE-CYLINDER VASE	*	11.98	
1/16/25		1413CCR- 202412	340-53800-49100	10% PROCESSING FEE-DEC24	*	247.38	
1/16/25		1413CCR- 202501	340-53800-51000	AMAZON-COFFEE CREAMER	*	27.98	
1/16/25		1413CCR- 202501	340-53800-51000	AMAZON-128GB FLASH DRIVE	*	12.77	
1/21/25		2095CCR- 202410	340-53800-54000	AMAZON-ANN.MEMBERSHIP FEE	*	179.00	
1/21/25		2095CCR- 202410	340-53800-51000	AMAZON-COLORED TONER CART	*	296.99	
1/21/25		2095CCR- 202409	340-53800-46900	AMAZON-SOAP DISPENSER/SOAP	*	256.32	

SIXM SIX MILE CREEK TVISCARRA

CHECK DATE	VEND#	INVOICE DATE	INVOICE	EXPENSED TO YRMO	ACCT#	SUB	SUBCLASS	VENDOR NAME	STATUS	AMOUNT	CHECK AMOUNT	CHECK #
1/21/25		2095CCR-	202411	340-53800-51000				AMAZON-4 ROKU REMOTES	*	39.96		
1/21/25		2095CCR-	202411	340-53800-51000				AMAZON-2 ROKU REMOTES	*	39.76		
THE REVERIE HOMEOWNERS' ASSOCIATION											24,752.44	000344
1/23/25	00030	1/14/25	9672/4	202501	340-53800-47500			DUCT TAPE/ACE FINISH 3D	*	15.98		
TURNER WGV LLC											15.98	000345
1/28/25	00051	1/24/25	33335640	202501	340-53800-47500			SVC CALL-RESET/CYCLE POWR	*	262.65		
AIR-MAX HEATING & COOLING INC											262.65	000346
1/28/25	00050	1/23/25	JAK01250	202501	340-53800-46700			DEEP CLEAN-MACH.SCRB/WNDW	*	525.00		
JANI-KING OF JACKSONVILLE											525.00	000347
1/28/25	00023	1/24/25	11030847	202412	320-53800-12200			FIELD OPER 12/14 - 12/27	*	384.62		
1/24/25		11030847	202412	340-53800-12100				ONSITE ADMIN 12/14-12/27	*	2,016.75		
1/24/25		11030847	202412	320-53800-12200				MGMT/ADMIN 12/14 - 12/27	*	2,592.00		
THE REVERIE HOMEOWNERS' ASSOCIATION											4,993.37	000348
1/28/25	00005	1/19/25	556887-1	202501	340-53800-43100			255 RUSTIC MILL DR-JAN25	*	15.69		
1/19/25		556887-1	202501	340-53800-43100				35 RUSTIC MILL DR - JAN25	*	2,888.41		
ST.JOHNS COUNTY UTILITY DEPT.											2,904.10	000349
1/28/25	00030	1/27/25	9735/4	202501	340-53800-47500			SPOT CLN/WOOD MRKR/CLOTH	*	166.56		
TURNER WGV LLC											166.56	000350
TOTAL FOR BANK D										97,856.60		
TOTAL FOR REGISTER										97,856.60		

SIXM SIX MILE CREEK TVISCARRA



A RENTOKIL COMPANY
PO BOX 740608
CINCINNATI OH 45274-0608

RECEIVED
JAN 03 2025

Bill To Number	Invoice Date	Amount Due
2994637	1/1/2025	296.55

PHONE: 877-284-8688
WEB: www.florida.bugoutservice.com
Text: 877-284-8688

INVOICE# 72934079 SIX MILE CREEK CDD

116
330-538-468



INVOICE DETAIL

Thank you for allowing us to provide the following services:

LAWN CARE SERVICE

296.55

Six Mile Creek Cdd Trailmark Amenities Center
805 TRAILMARK DR
SAINT AUGUSTINE , FL ON 1/1/2025

APPROVED
By Alex Boyer at 11:21 am, Jan 06, 2025

Amenity-pest control

Payment Receipt. Please Return with Payment Remittance



A RENTOKIL COMPANY
PO Box 13848
Reading, PA 19612-3848

Bill To #: 2994637	Date: 1/1/2025
Due Date: 1/31/2025	Invoice #: 72934079
Amount Due: 296.55	Amount Paid: \$296.55
	Check No.: 534



Seq#: 000001
Six Mile Creek Cdd
6200 Lee Vista Blvd
Ste 300
Orlando, FL 32822-5149



BUG OUT
PO BOX 740608
CINCINNATI OH 45274-0608

002994637000000000072934079000029655202501310002

INVOICE

BrightView

Landscape Services

Sold To: 22539664
Six Mile CDD
475 W Town Pl Ste 114
St Augustine FL 32092

#170
320-538-466

Customer #: 22539664
Invoice #: 9195131
Invoice Date: 12/26/2024
Sales Order: 8572969
Cust PO #:

RECEIVED
DEC 26 2024
BY: _____

Project Name: Six Mile Cdd- 76 split Oak

Project Description: general tree

Job Number	Description	Amount
460800520	Six Mile CDD Trailmark 76 Split Oak APPROVED <i>By Alex Boyer at 10:48 am, Jan 06, 2025</i> O&M-Landscape cont	1,690.14
Total Invoice Amount		1,690.14
Taxable Amount		
Tax Amount		
Balance Due		1,690.14

Terms: Net 15 Days

If you have any questions regarding this invoice, please call

Please detach stub and remit with your payment

Payment Stub

Customer Account #: 22539664
Invoice #: 9195131
Invoice Date: 12/26/2024

Amount Due: \$1,690.14

Thank you for allowing us to serve you

Please reference the invoice # on your check and make payable to

Six Mile CDD
475 W Town Pl Ste 114
St Augustine FL 32092

BrightView Landscape Services, Inc.
P.O. Box 740655
Atlanta, GA 30374-0655

INVOICE

BrightView

Landscape Services

Sold To: 22539672
Six Mile CDD Trailmark
805 Trailmark Drive
St Augustine FL 32092

#170
320-578-462

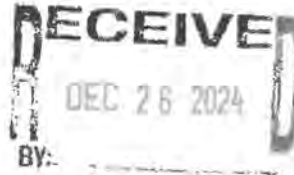

Customer #: 22539672
Invoice #: 9195324
Invoice Date: 12/26/2024
Sales Order: 8578613
Cust PO #:

Job Number	Description	Amount
460800520	Six Mile CDD Trailmark <u>December Monthly Maintenance</u> Irrigation Chemspray O&M-Landscape	30,583.28
Total Invoice Amount		30,583.28
Taxable Amount		
Tax Amount		
Balance Due		30,583.28

APPROVED
By Alex Boyer at 11:21 am, Jan 06, 2025

Terms: Net 15 Days

If you have any questions regarding this invoice, please call

Please detach stub and remit with your payment

Payment Stub

Customer Account #: 22539672
Invoice #: 9195324
Invoice Date: 12/26/2024

Amount Due: \$ 30,583.28

Thank you for allowing us to serve you

Please reference the invoice # on your check and make payable to

Six Mile CDD Trailmark
805 Trailmark Drive
St Augustine FL 32092

BrightView Landscape Services, Inc.
P.O. Box 740655
Atlanta, GA 30374-0655

INVOICE

BrightView

Landscape Services

Sold To: 22539664
Six Mile CDD
475 W Town Pl Ste 114
St Augustine FL 32092

#170
320-598-4620

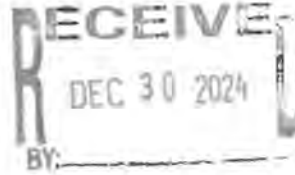

Customer #: 22539664
Invoice #: 9197515
Invoice Date: 12/30/2024
Sales Order: 8558275
Cust PO #:

Project Name: Six Mile CDD Winter Annuals 2024
Project Description: Color

Job Number	Description	Amount
460800520	Six Mile CDD Trailmark Winter Flowers <div style="border: 1px solid black; padding: 5px; text-align: center;">APPROVED <i>By Alex Boyer at 11:21 am, Jan 06, 2025</i></div> O&M-Annual flowers	2,175.52
Total Invoice Amount		2,175.52
Taxable Amount		
Tax Amount		
Balance Due		2,175.52

Terms: Net 15 Days

If you have any questions regarding this invoice, please call

Please detach stub and remit with your payment

Payment Stub

Customer Account #: 22539664
Invoice #: 9197515
Invoice Date: 12/30/2024

Amount Due: \$ 2,175.52

Thank you for allowing us to serve you

Please reference the invoice # on your check and make payable to

Six Mile CDD
475 W Town Pl Ste 114
St Augustine FL 32092

BrightView Landscape Services, Inc.
P.O. Box 740655
Atlanta, GA 30374-0655

INVOICE

C Buss Enterprises
152 Lipizzan Trail
Saint Augustine, FL 32095

clayton@cbussenterprises.com
+1 (904) 710-8161
<https://www.cbussenterprises.com>



Bill to
Six Mile Creek CDD
6200 Lee Vista Boulevard
Suite 300
Orlando, FL 32822

Ship to
Six Mile Creek CDD
805 Trailmark Dr
Jacksonville, FL 32092

APPROVED
By Alex Boyer at 10:17 am, Dec 30, 2024

Amenit-pool maint

Invoice details

Invoice no.: 2817
Terms: Due on receipt
Invoice date: 12/25/2024
Due date: 01/01/2025



#	Product or service	Description	Qty	Rate	Amount
1.	COMMERCIAL POOL SERVICE	MONTHLY POOL SERVICE #237 330-538 465	1	\$1,800.00	\$1,800.00
2.	BICARB	PER LB 330-538 46501	36	\$1.25	\$45.00
Total					\$1,845.00

THANK YOU FOR YOUR BUSINESS! PLEASE MAKE CHECKS
PAYABLE TO C BUSS ENTERPRISES AND MAIL TO 152 LIPIZZAN
TRAIL, ST. AUGUSTINE, FL 32095

Crabtree Plumbing, Inc.
2351 Urban Road
Jacksonville, FL 32210 US
+1 9043844604
crabtreeplumb@aol.com
www.crabtreeplumbing.net

Crabtree Plumbing Inc.

Invoice

BILL TO

Trailmark 6 Mile Creek CDD
805 Trailmark Dr
St. Augustine, Fl 32092

SHIP TO

Trailmark 6 Mile Creek CDD
805 Trailmark Dr
St. Augustine, Fl 32092

INVOICE #	DATE	TOTAL DUE	DUE DATE	TERMS	ENCLOSED
236360	12/30/2024	\$380.00	01/29/2025	Net 30	

282
330-578-146

DATE	DESCRIPTION	QTY	RATE	AMOUNT
	Woman's Bath Was Clogged Up/Used The Camera To Unstop Drain Line/Went Through Clean Out In Floor	1	380.00	380.00

Thank you for your business!

BALANCE DUE

\$380.00

Please be advised there is a 3% credit processing fee

APPROVED
By Alex Boyer at 10:25 am, Dec 31, 2024

Amenity-repair

RECEIVED
DEC 31 2024
BY: _____

Governmental Management Services, LLC

475 West Town Place, Suite 114
St. Augustine, FL 32092

Invoice

Invoice #: 192
Invoice Date: 1/1/25
Due Date: 1/1/25
Case:
P.O. Number:

Bill To:

Six Mile Creek CDD
475 West Town Place
Suite 114
St. Augustine, FL 32092



Description	#1	Hours/Qty	Rate	Amount
Management Fees -January 2025	310 813-34		3,750.00	3,750.00
Website Administration - January 2025	332		105.00	105.00
Information Technology -January 2025	331		157.50	157.50
Dissemination Agent Services -January 2025	313		1,143.33	1,143.33
Office Supplies	51		2.53	2.53
Postage	42		134.37	134.37
Copies	425		135.45	135.45
Telephone	41		118.42	118.42
Total				\$5,546.60
Payments/Credits				\$0.00
Balance Due				\$5,546.60

IH BRANDS

CREATING PERSONALIZED PRODUCTS

2021-2 St. Augustine Road E, Jacksonville, FL 32207
888-465-6373



INV:92528669

ACCT#	DATE	TERMS	BIN/CNT
301956	12/6/2024	NET30	5621-4
PO# NET30; NT# 8132028			

DHL: DHL Expedited (18 oz)
Tracking#: 9292612903397006064

BILL TO:
GMS - GOVERNMENTAL MANAGEMENT SERVICES
475 WEST TOWN PLACE
SUITE 114
ST. AUGUSTINE, FL 32092

SHIP TO:
SARAH SWEETING
475 W TOWN PL STE 114
SAINT AUGUSTINE, FL 32092-3649

#152
310-57-4911

QTY	SKU	DESCRIPTION	LIST	PRICE	TOTAL
1	210D Option	DESK SIGN 2X10 ALUMINUM W/INSERT -- Michelle Sutton Logo : None	20.00 0.00	14.99 0.00	14.99
1	210D Option	DESK SIGN 2X10 ALUMINUM W/INSERT -- Heather Brofford Logo : None	20.00 0.00	14.99 0.00	14.99
1	210D Option	DESK SIGN 2X10 ALUMINUM W/INSERT -- Mindy Gellman Logo : None	20.00 0.00	14.99 0.00	14.99
1	210D Option	DESK SIGN 2X10 ALUMINUM W/INSERT -- Jacob Dunn Logo : None	20.00 0.00	14.99 0.00	14.99
1	DHLGRND	SHIPPING AND HANDLING - DHL GROUND	9.99	9.99	9.99
		TOTAL			69.95

RECEIVED
JAN 02 2024
BY:

We appreciate your business !!!

Municipal Asset Management, Inc.

25288 Foothills Drive North
Suite 225
Golden, CO 80401
(303) 273-9494

INVOICE

INVOICE NO: 0619389
DATE: 1/1/2025

To: Six Mile Creek Community Development Dist
Teresa Viscarra
475 West Town Place, Suite 114
St. Augustine, FL 32092

RECEIVED
JAN 05 2025
BY: _____

DUE DATE	RENTAL PERIOD
2/27/2025	

PMT NUMBER	DESCRIPTION	AMOUNT
24	<u>Lease payment</u> for Tax-Exempt Lease Purchase Agreement dated October 19, 2022 for the purchase of <u>fitness</u> equipment (Trailmark) #31 310517-71-32423.48 310517 72-5433.86	2,859.34

TOTAL DUE

\$2,859.34

Please detach coupon and return with check payable to MUNICIPAL ASSET MANAGEMENT, INC. and remit to address above.

If you have any questions concerning this invoice,
call: Municipal Asset Management, Paul Collings, (303) 273-9494.

THANK YOU FOR YOUR BUSINESS!

Invoice #	Due Date	Total Due	Amount Enclosed
0619389	2/27/2025	\$2,859.34	\$2859.34

Six Mile Creek Community Development Dist
Teresa Viscarra
475 West Town Place, Suite 114
St. Augustine, FL 32092

Municipal Asset Management, Inc.
25288 Foothills Drive North
Suite 225
Golden, CO 80401

INVOICE

Sitex Aquatics, LLC
PO Box 917
Parrish, FL 34219

office@sitexaquatics.com
+1 (813) 564-2322



#39
320-578-464

Six Mile Creek-CDD

Bill to

Six Mile Creek CDD
Teresa Viscarra
GMS

APPROVED

By Alex Boyer at 10:18 am, Jan 02, 2025

O&M-Lake Maint

Ship to

Six Mile Creek CDD
Teresa Viscarra
GMS

Invoice details

Invoice no.: 9415-B
Terms: Net 30
Invoice date: 01/01/2025
Due date: 01/31/2025



#	Date	Product or service	Description	Qty	Rate	Amount
1.		Aquatic Maintenance	Monthly Lake Maintenance- 37 Waterways	1	\$4,220.00	\$4,220.00
Total						\$4,220.00

Invoice

Invoice Number
24-58550

Invoice Date
1/1/25

Page
1

Security Engineering And Designs, Inc.
3139 Waller Street
Jacksonville, FL 32254

APPROVED
By Alex Boyer at 11:18 am, Dec 30, 2024

Voice: 904-371-4931

Fax:

Amenity-Security

Sold To:

Trailamrk Amenity Center (6 MILE CREEK)
6200 LEE VISTA BLVD.
STE. 300
ORLANDO , FL 32822

#84
320-538-346

Site Address:

Trailamrk Amenity Center
805 Trailmark Dr.
St. Augustine, FL 32092



Customer ID: TA-3315-5F

Customer PO	Payment Terms	Sales Rep ID	Due Date
	Net 10 Days		1/11/25

Description	Amount
<u>MONTHLY FIRE ALARM MONITORING SERVICE</u>	34.95

Service Department: 371-4931
Monitoring Center: 800-318-9486
Installation: 371-4931

Please include invoice number on payment

24-58550

Subtotal	34.95
Sales Tax	
Total Invoice Amount	34.95
Payment Received	0.00
TOTAL	34.95



1824 Phoenix Avenue
Jacksonville, FL 32206

Please remit check payments to:
P.O. Box 3264
Jacksonville, FL 32206

Invoice

Date	Invoice #
12/18/2024	24-01501

Bill To

SIX MILE CREEK CDD
475 WEST TOWN PLACE, SUITE 114
ST. AUGUSTINE, FL 32092

#128
320-578 465

Ship To

Trailmark
805 Trailmark Dr
St Augustine, FL 32092

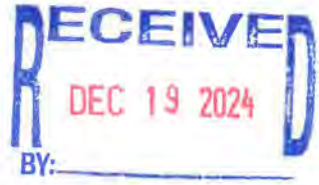

P.O. Number	Terms	Rep	Via	Project
	Due on receipt	JW		PM Inspection

Description	Quantity	Price Each	U/M	Amount
Predictive Maintenance Inspection for Trailmark Lap Pool and Lagoon Pool.		700.00		700.00
Sales Tax - Florida		6.00%		0.00
<div style="border: 1px solid black; padding: 5px; display: inline-block;"> <p>APPROVED By Alex Boyer at 10:03 am, Dec 19, 2024</p> </div>				
Amenity-pool maint				

All work is complete!

Total	\$700.00
Payments	\$0.00
Balance Due	\$700.00

PLEASE NOTE:
DEPOSITS ARE NON-REFUNDABLE ONCE CONSTRUCTION HAS STARTED.
CREDIT CARD PAYMENTS ARE SUBJECT TO A 3.5% PROCESSING FEE.



ENGLAND-THIMS & MILLER



14775 Old St. Augustine Road, Jacksonville, FL 32258

etminc.com | 904.642.8990

Six Mile Creek Community Development District
6200 Lee Vista Boulevard Ste 300
Orlando, FL 32822

November 27, 2024
Invoice No: 217104

Total This Invoice \$2,171.50

Project 22397.02000 Six Mile Creek - 2024/2025 General Consulting Engineering Services (WA#82)

Professional Services rendered through November 23, 2024

Phase 01, General Consulting Engineering Services

Labor

			Hours	Rate	Amount
Executive Vice President					
Wild, Scott	11/2/2024		1.00	362.00	362.00
Wild, Scott	11/9/2024		1.00	362.00	362.00
Wild, Scott	11/16/2024		1.00	362.00	362.00
Senior Engineer/Senior Project Manager					
Wild, Scott	11/23/2024		1.00	244.00	244.00
Administrative Support					
Blair, Shelley	11/9/2024		1.50	99.00	148.50
Blair, Shelley	11/16/2024		2.25	99.00	222.75
Blair, Shelley	11/23/2024		4.75	99.00	470.25
	Totals		12.50		2,171.50
	Total Labor				2,171.50

Billing Limits	Current	Prior	To-Date
Labor	2,171.50	2,090.75	4,262.25
Limit			25,000.00
Remaining			20,737.75

Total this Phase \$2,171.50

Phase XP, Expenses

Total this Phase 0.00

Total This Invoice \$2,171.50



ENBLAND-THIMS & MILLER



14775 Old St. Augustine Road, Jacksonville, FL 32258

etminc.com | 904.642.8990

Six Mile Creek Community Development District
6200 Lee Vista Boulevard Ste 300
Orlando, FL 32822

#22
310-57-311

January 03, 2025

Invoice No: 217508

Total This Invoice \$3,235.50

Project 22397.02000 Six Mile Creek - 2024/2025 General Consulting Engineering Services (WA#82)

Professional Services rendered through December 28, 2024

Phase 01 General Consulting Engineering Services

Labor

			Hours	Rate	Amount
Senior Engineer/Senior Project Manager					
Wild, Scott	11/30/2024	BOS meeting, prep and follow up	3.00	244.00	732.00
Wild, Scott	12/7/2024	reqs	1.00	244.00	244.00
Wild, Scott	12/14/2024	bos mtg, prep and follow up	4.00	244.00	976.00
Wild, Scott	12/14/2024	reqs	1.00	244.00	244.00
Adminstrative Support					
Blair, Shelley	11/30/2024	Create and distribute Phase 12 Change Order No. 22	1.00	99.00	99.00
Blair, Shelley	12/7/2024	DOP Requisitions & email correspondence	.50	99.00	49.50
Blair, Shelley	12/14/2024	Email Correspondence	.75	99.00	74.25
Blair, Shelley	12/14/2024	Create and distribute Dec 11th Requisition Summary and Engineer Items	1.00	99.00	99.00
Blair, Shelley	12/14/2024	Prepare and distribute requisition	.50	99.00	49.50
Blair, Shelley	12/14/2024	Prepare and distribute requisitions	1.00	99.00	99.00
Blair, Shelley	12/14/2024	Revise and distribute Dec 11 CDD Meeting items	1.50	99.00	148.50
Blair, Shelley	12/21/2024	Email Correspondence	.25	99.00	24.75
Blair, Shelley	12/21/2024	Create and Distribute requisitions	1.00	99.00	99.00
Blair, Shelley	12/21/2024	Distribute requisitions	.50	99.00	49.50
Blair, Shelley	12/21/2024	Onsight Requisition	.50	99.00	49.50
Blair, Shelley	12/28/2024	Email correspondence	.50	99.00	49.50

Blair, Shelley	12/28/2024	1.50	99.00	148.50
Requisitions and email correspondence				
Totals		19.50		3,235.50
Total Labor				3,235.50

Billing Limits	Current	Prior	To-Date
Labor	3,235.50	4,262.25	7,497.75
Limit			25,000.00
Remaining			17,502.25
Total this Phase			\$3,235.50

Phase	XP	Expenses	Total this Phase	0.00
-------	----	----------	-------------------------	-------------

Total This Invoice \$3,235.50

Outstanding Invoices

Number	Date	Balance
217104	11/27/2024	2,171.50
Total		2,171.50
Total Now Due		\$5,407.00



Pay by Phone (844) 752-8845
 Phone (904) 209-2700
 Fax (904) 209-2718
 Toll Free (877) 837-2311

PO Drawer 3006
 St. Augustine, FL 32085

Statement Date 12/19/2024	Current Charges Due Date 01/18/2025
-------------------------------------	---

Current Month Activity

Services Dates	Service Description	Units	Amount	Total
11/19/24	Amount of Your Last Statement			2,774.21
12/2/24	Payment - Thank You		-2,774.21	
	Past Due Balance			0.00
Water Rates				
	Meter Maintenance Charge	9.00	1.00	9.00
	Base Rate	123.52	1.00	123.52
Consumption Fees	0 - 40,000 Gallons	3.92	40.00	156.80
	40,001 - 80,000 Gallons	4.89	40.00	195.60
	80,001 - 160,000 Gallons	8.25	80.00	660.00
	160,001 + Gallons	11.29	15.20	171.61
	Water Total		175.20	1,316.53
Wastewater Rates				
	Base Rate	145.10	1.00	145.10
Consumption Fees	0 + Sewer Gallons	6.83	175.20	1,196.62
	Wastewater Total		175.20	1,341.72
	Past Due Balance			0.00
	Current Charges			2,658.25
	Amount Now Due / Credits			2,658.25



SIX MILE CREEK CDD/TRAILMARK SUBDIVISION

Account Number:
556887-132900

Service Address:
805 TRAILMARK DR

Service Type:

Commercial

Days in Billing Cycle: 30

Deposit Amount: \$ 0.00

Deposit Date:

Geo Code: WGV

Meter Number: 77848570

Present Read Date: 12/19/2024

Previous Read Date: 11/19/2024

Current Reading: 1527150

Previous Reading: 1509630

Gallons Used: 175,200.00

#24
330-578431

Past Due Balances are subject to a Late Fee of 1.5% or \$5.00, whichever is greater and disconnection of service if not paid.

MESSAGE CENTER

In 2023, SJCUD detected 13 contaminants in the drinking water. All contaminants were at allowable levels & no health based violations were reported. Please go to www.sjcf.us/WaterReport/NorthWest.pdf to view you report. This report contains important info about the source & quality of your water. To receive a hard copy of the report or if you have any questions please call 904-209-2700.

www.sjcutility.us

See reverse for monthly draft options or credit card payments.

Please detach and return with your payment.

FL29539F



ST JOHNS COUNTY UTILITY DEPARTMENT
 POST OFFICE DRAWER 3006
 ST AUGUSTINE FL 32085-3006

Account Number 556887-132900		Date Due 01/18/2025	
Past Due Amount 0.00	Current Charges/Credits 2,658.25	Amount Now Due 2,658.25	After Due Date Pay 2,698.12
Please Enter Amount Paid \$		2658.25	



Please write your account number on your check and remit to:

ST JOHNS COUNTY UTILITY DEPARTMENT
 POST OFFICE DRAWER 3006
 ST AUGUSTINE FL 32085-3006



*****AUTO**MIXED AADC 302



SIX MILE CREEK CDD/TRAILMARK SUBDIVISION
 6200 LEE VISTA BLVD STE 300 3216
 ORLANDO FL 32822-5149



000000132900000000556887000000265825000000269812

Check for Address Change



Pay by Phone (844) 752-8845
 Phone (904) 209-2700
 Fax (904) 209-2718
 Toll Free (877) 837-2311

PO Drawer 3006
 St. Augustine, FL 32085

Statement Date 12/19/2024	Current Charges Due Date 01/18/2025
-------------------------------------	---

Current Month Activity

Services Dates	Service Description	Units	Amount	Total
11/19/24	Amount of Your Last Statement			38.64
12/2/24	Payment - Thank You		-38.64	
	Past Due Balance			0.00
	Water Rates			
	Base Rate	38.60	1.00	38.60
Consumption Fees	0 - 12,500 Gallons	3.92		0.00
	Water Total			38.60
	Past Due Balance			0.00
	Current Charges			38.60
	Amount Now Due / Credits			38.60

SIX MILE CREEK CDD/TRAILMARK SUBDIVISION

Account Number:
556887-135864

Service Address:
295 BACK CREEK DR

Service Type:

Commercial

Days in Billing Cycle: 30

Deposit Amount: \$ 0.00

Deposit Date:

Geo Code: WGV

Meter Number: 86147234

Present Read Date: 12/19/2024

Previous Read Date: 11/19/2024

Current Reading: 173

Previous Reading: 173

Gallons Used: 0.00

#24

370-578-431

Past Due Balances are subject to a Late Fee of 1.5% or \$5.00, whichever is greater and disconnection of service if not paid.

MESSAGE CENTER

In 2023, SJCUD detected 13 contaminants in the drinking water. All contaminants were at allowable levels & no health based violations were reported. Please go to www.sjcfi.us/WaterReport/NorthWest.pdf to view you report. This report contains important info about the source & quality of your water. To receive a hard copy of the report or if you have any questions please call 904-209-2700.

www.sjcutility.us

See reverse for monthly draft options or credit card payments.

Please detach and return with your payment.

FL29539F



ST JOHNS COUNTY UTILITY DEPARTMENT
 POST OFFICE DRAWER 3006
 ST AUGUSTINE FL 32085-3006

Account Number		Date Due	
556887-135864		01/18/2025	
Past Due Amount	Current Charges/Credits	Amount Now Due	After Due Date Pay
0.00	38.60	38.60	43.60
Please Enter Amount Paid \$		38.60	



Please write your account number on your check and remit to:

 SIX MILE CREEK CDD/TRAILMARK SUBDIVISION
 6200 LEE VISTA BLVD STE 300
 ORLANDO FL 32822-5149

ST JOHNS COUNTY UTILITY DEPARTMENT
 POST OFFICE DRAWER 3006
 ST AUGUSTINE FL 32085-3006



000000135864000000556887000000003860000000004360

Check for Address Change



January 1, 2025

Invoice No.
2501-TSMC

INVOICE

Prepared for Six Mile Creek CDD
805 Trailmark Dr. St. Augustine, FL 32092

DESCRIPTION OF WORK	STATIONS	VISITS	TOTAL
Servicing for - <u>January</u> <ul style="list-style-type: none"> <u>Pet Waste Station Maintenance</u> 	2 stations	2 X Week	\$206
<div style="border: 1px solid black; padding: 5px; display: inline-block;"> <p>APPROVED By Alex Boyer at 9:19 am, Jan 09, 2025</p> </div> <p>O&M-Dog Park</p>			
#162 320-338-477			
		TOTAL	\$206
		PAID	



ACCOUNT NAME Six Mile Creek Cdd C/O Gms Llc		ACCOUNT # 764132	PAGE # 1 of 1
INVOICE # 0006884751	BILLING PERIOD Dec 1- Dec 31, 2024	PAYMENT DUE DATE January 20, 2025	
PREPAY (Memo Info) \$0.00	UNAPPLIED (Included in amt due) \$0.00	TOTAL CASH AMT DUE* \$65.92	

BILLING ACCOUNT NAME AND ADDRESS Six Mile Creek Cdd C/O Gms Llc 475 W. Town Pl. Ste. 114 Saint Augustine, FL 32092-3649 	Legal Entity: Gannett Media Corp. Terms and Conditions: Past due accounts are subject to interest at the rate of 18% per annum or the maximum legal rate (whichever is less). Advertiser claims for a credit related to rates incorrectly invoiced or paid must be submitted in writing to Publisher within 30 days of the invoice date or the claim will be waived. Any credit towards future advertising must be used within 30 days of issuance or the credit will be forfeited. All funds payable in US dollars.
--	---

BILLING INQUIRIES/ADDRESS CHANGES 1-877-736-7612 or smb@ccc.gannett.com FEDERAL ID 47-2390983

To sign-up for E-mailed invoices and online payments please contact abgspecial@gannett.com.

Date	Description	Amount
12/1/24	Balance Forward	\$65.92
12/26/24	PAYMENT - THANK YOU	-\$65.92

Package Advertising:

Start-End Date	Order Number	Product	Description	PO Number	Package Cost
12/31/24	10861295	SAG St Augustine Record	Six Mile Creek	Six Mile Creek	\$65.92

#235
210 513 48

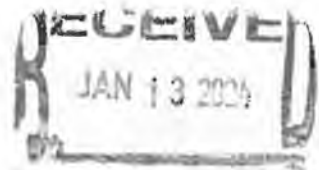

As an incentive for customers, we provide a discount off the total invoice cost equal to the 3.99% service fee if you pay with Cash/Check/ACH. Pay by Cash/Check/ACH and Save!

Total Cash Amount Due	\$65.92
Service Fee 3.99%	\$2.63
*Cash/Check/ACH Discount	-\$2.63
*Payment Amount by Cash/Check/ACH	\$65.92
Payment Amount by Credit Card	\$68.55

PLEASE DETACH AND RETURN THIS PORTION WITH YOUR PAYMENT

ACCOUNT NAME Six Mile Creek Cdd C/O Gms Llc		ACCOUNT NUMBER 764132		INVOICE NUMBER 0006884751		AMOUNT PAID \$65.92
CURRENT DUE \$65.92	30 DAYS PAST DUE \$0.00	60 DAYS PAST DUE \$0.00	90 DAYS PAST DUE \$0.00	120+ DAYS PAST DUE \$0.00	UNAPPLIED PAYMENTS \$0.00	TOTAL CASH AMT DUE* \$65.92
REMITTANCE ADDRESS (Include Account# & Invoice# on check)					TO PAY WITH CREDIT CARD PLEASE CALL:	
Gannett Florida LocaliQ PO Box 631244 Cincinnati, OH 45263-1244					1-877-736-7612	
					TOTAL CREDIT CARD AMT DUE \$68.55	
					To sign up for E-mailed invoices and online payments please contact abgspecial@gannett.com	

00007641320000000000000068847510000659267176

LOCALiQ

FLORIDA

PO Box 631244 Cincinnati, OH 45263-1244

AFFIDAVIT OF PUBLICATION

Six Mile Creek Cdd C/O Gms Llc
Six Mile Creek Cdd C/O Gms Llc
475 West Town Place, Ste 114

Saint Augustine FL 32092

STATE OF WISCONSIN, COUNTY OF BROWN

Before the undersigned authority personally appeared, who on oath says that he or she is the Legal Coordinator of the St Augustine Record, published in St Johns County, Florida; that the attached copy of advertisement, being a Public Notices, was published on the publicly accessible website of St Johns County, Florida, or in a newspaper by print in the issues of, on:

12/31/2024

Affiant further says that the website or newspaper complies with all legal requirements for publication in chapter 50, Florida Statutes.

Subscribed and sworn to before me, by the legal clerk, who is personally known to me, on 12/31/2024



Legal Clerk



Notary, State of WI, County of Brown

8.25.26

My commission expires

Publication Cost:	\$65.92	
Tax Amount:	\$0.00	
Payment Cost:	\$65.92	
Order No:	10861295	# of Copies:
Customer No:	764132	1
PO #:	Six Mile Creek	

THIS IS NOT AN INVOICE!

Please do not use this form for payment remittance.

MARIAH VERHAGEN
Notary Public
State of Wisconsin

Notice of Meeting Six Mile Creek

Community Development District
The regular meeting of the Board of Supervisors of the Six Mile Creek Community Development District will be held on Wednesday, January 8, 2025 at 2:00 p.m. at the Renaissance World Golf Village Resort, 500 South Legacy Trail, St. Augustine, Florida 32092. The meeting is open to the public and will be conducted in accordance with the provisions of Florida Law for Community Development Districts. A copy of the agenda for this meeting may be obtained from the District Manager, 475 West Town Place, Suite 114, St. Augustine, Florida 32092 (and phone (904) 940-5850). This meeting may be continued to a date, time, and place to be specified on the record at the meeting. There may be occasions when one or more Supervisors will participate by telephone.

Any person requiring special accommodations at this meeting because of a disability or physical impairment should contact the District Office at (904) 940-5850 at least two calendar days prior to the meeting. If you are hearing or speech impaired, please contact the Florida Relay Service at 1-800-955-8770, for aid in contacting the District Office. Each person who decides to appeal any action taken at this meeting is advised that person will need a record of the proceedings and that accordingly, the person may need to ensure that a verbatim record of the proceedings is made, including the testimony and evidence upon which such appeal is to be based.

James Oliver
District Manager



STA Trivia

"Play how the Locals Play!"



INVOICE

INVOICE JANUARY 2024

01-08-2025

Maass Enterprises
81 Ashby Landing Way
St. Augustine, FL 32086
Phone (806)-8669 | statrivia904@gmail.com |
<https://www.statrivia.com/>

TO
Board of Directors
Six Mile Creek CDD
475 West Town Place Suite 114 St. Augustine, FL 32092
Phone (904) 516-0102 | hello@trailmarkliving.com

FOR STA Trivia nights

#283
320-538-492

Description	Amount
Trivia Night (01/24/25)	\$200
Total	\$200

Make all checks payable to: Maass Enterprises.

Please mail check to:
Paul Maass
81 Ashby Landing Way
St. Augustine, FL 32086

If you have any questions concerning this invoice, contact Paul Maass | (904) 806-8669 |
statrivia904@gmail.com THANK YOU FOR YOUR BUSINESS!



RENAISSANCE®
WORLD GOLF VILLAGE RESORT
ST AUGUSTINE

Account 5502

500 S Legacy Trail
St Augustine, FL 32092
(904) 940-8606 fax (904) 940-8590

INVOICE **=**

Customer

Name Six Mile Creek Meeting
Address 475 W Town Place, Suite 114
City Saint Augustine, FL 32092-3648

Date 1/10/2025

Qty	Description	Charged
1	Total Meeting Charges	\$1,706.24
1	Less State Taxes	(\$21.50)
1	Less Meeting Room Taxes	(\$30.88)
1	Less Advance Deposits	(\$1,464.88)
	#98 210-517.44	
Six Mile Creek Community Development District Certificate Number 85-8013854049C-1		

SUB-TOTAL \$188.98

Amount Due \$188.98

Payment Details

- Direct Bill
- Check
- Credit Card



Corporate Trust Services
EP-MN-WN3L
60 Livingston Ave.
St. Paul, MN 55107

Invoice Number: 7589535
Account Number: 271832000
Invoice Date: 12/24/2024
Direct Inquiries To: Schuhle, Scott A
Phone: (954)-938-2476

Six Mile Creek Community Development District
c/o GMS - North Florida, LLC
475 West Town Place, Suite 114
St. Augustine, FL 32092
United States

**SIX MILE CREEK COMMUNITY DEVELOPMENT DISTRICT CAPITAL IMPROVEMENT REVENUE BONDS
SERIES 2021 ASSESSMENT AREA 3 PHASE 2 REVENUE ACCOUNT**

The following is a statement of transactions pertaining to your account. For further information, please review the attached.

STATEMENT SUMMARY

PLEASE REMIT BOTTOM COUPON PORTION OF THIS PAGE WITH CHECK PAYMENT OF INVOICE.

TOTAL AMOUNT DUE \$7,273.13

All invoices are due upon receipt.

21
Trustee Fees - Ser.
210-513 323

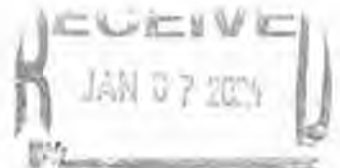

Please detach at perforation and return bottom portion of the statement with your check, payable to U.S. Bank.

**SIX MILE CREEK COMMUNITY DEVELOPMENT
DISTRICT CAPITAL IMPROVEMENT REVENUE BONDS
SERIES 2021 ASSESSMENT AREA 3 PHASE 2
REVENUE ACCOUNT**

Invoice Number: 7589535
Account Number: 271832000
Current Due: \$7,273.13

Direct Inquiries To: Schuhle, Scott A
Phone: (954)-938-2476

Wire Instructions:
U.S. Bank
ABA #1
Acct #
Trust Acct #
Invoice # 7589535
Attn: Fee Dept St. Paul

Please mail payments to:
U.S. Bank
CM-9690
PO BOX 70870
St. Paul, MN 55170-9690





Corporate Trust Services
 EP-MN-WN3L
 60 Livingston Ave.
 St. Paul, MN 55107

Invoice Number: 7589535
 Invoice Date: 12/24/2024
 Account Number: 271832000
 Direct Inquiries To: Schuhle, Scott A
 Phone: (954)-938-2476

SIX MILE CREEK COMMUNITY DEVELOPMENT
 DISTRICT CAPITAL IMPROVEMENT REVENUE BONDS
 SERIES 2021 ASSESSMENT AREA 3 PHASE 2
 REVENUE ACCOUNT

Accounts Included	226000000	226000001	226000002	226000003	226000004	226000005
In This Relationship:	271832000	271832001	271832002	271832003	271832004	271832005

CURRENT CHARGES SUMMARIZED FOR ENTIRE RELATIONSHIP

Detail of Current Charges	Volume	Rate	Portion of Year	Total Fees
04111 Paying Agent / Regist / Trustee Agent	1.00	4,000.00	100.00%	\$4,000.00
04111 Paying Agent / Regist / Trustee Agent	1.00	2,750.00	100.00%	\$2,750.00
Subtotal Administration Fees - In Advance 12/01/2024 - 11/30/2025				\$6,750.00
Incidental Expenses 12/01/2024 to 11/30/2025	6,750.00	0.0775		\$523.13
Subtotal Incidental Expenses				\$523.13
TOTAL AMOUNT DUE				\$7,273.13



BrightView

Landscape Services

Six Mile CDD
475 W Town Pl Ste 114
St Augustine FL 32092

JAN 20 2025

Customer #: 22539664
Invoice #: 9212569
Invoice Date: 1/1/2025
Cust PO #:

Job Number	Description	Amount
460800520	Six Mile CDD Trailmark Exterior Maintenance For January APPROVED <i>By Alex Boyer at 9:25 am, Jan 22, 2025</i> O&M-Landscape contract	35,170.83
Total invoice amount		35,170.83
Tax amount		
Balance due		35,170.83

Terms: Net 15 Days

If you have any questions regarding this invoice, please call -

Please detach stub and remit with your payment

Did you know that BrightView now offers auto ACH as a payment method? Discover the convenience and safety of automatic ACH bill payment for your recurring billing. Please contact autopay@brightview.com or your branch point of contact for more information on how to sign up on Auto Pay.

Payment Stub

Customer Account#: 22539664
Invoice #: 9212569
Invoice Date: 1/1/2025

Amount Due: \$35,170.83

Thank you for allowing us to serve you

Please reference the invoice # on your check
and make payable to:

Six Mile CDD
475 W Town Pl Ste 114
St Augustine FL 32092

BrightView Landscape Services, Inc.
P.O. Box 740655
Atlanta, GA 30374-0655

INVOICE

BrightView

Landscape Services

Sold To: 22539664
Six Mile CDD
475 W Town Pl Ste 114
St Augustine FL 32092



Customer #: 22539664
Invoice #: 9212084
Invoice Date: 1/20/2025
Sales Order: 8585878
Cust PO #:

Project Name: Six Mile CDD Trailmark: Mainline repair by the cloverly pump
Project Description: Six Mile CDD Trailmark: Mainline repair by the cloverly pump

Job Number	Description	Amount
460800520	Six Mile CDD Trailmark Misc. PVC pipe and fittings Labor O&M-Irrigation maint #170 20 578-483	762.87
APPROVED <i>By Alex Boyer at 9:49 am, Jan 21, 2025</i>		
Total Invoice Amount		762.87
Taxable Amount		
Tax Amount		
Balance Due		762.87

Terms: Net 15 Days

If you have any questions regarding this invoice, please call

Please detach stub and remit with your payment

Payment Stub

Customer Account #: 22539664
Invoice #: 9212084
Invoice Date: 1/20/2025

Amount Due: \$ 762.87

Thank you for allowing us to serve you

Please reference the invoice # on your check and make payable to

Six Mile CDD
475 W Town Pl Ste 114
St Augustine FL 32092

BrightView Landscape Services, Inc.
P.O. Box 740655
Atlanta, GA 30374-0655

INVOICE

BrightView

Landscape Services

RECEIVED
JAN 21 2025

Sold To: 22539664 #170
Six Mile CDD
475 W Town Pl Ste 114 22538463
St Augustine FL 32092

Customer #: 22539664
Invoice #: 9212085
Invoice Date: 1/20/2025
Sales Order: 8581771
Cust PO #:

Project Name: Six Mile CDD Trailmark: Valve replacement and Electrical troubleshooting
Project Description: Six Mile CDD Trailmark: Valve replacement and Electrical troubleshooting

Job Number	Description	Amount
460800520	AREAS AFFECTED BY DOWNED VALVES AND DECODERS: PLANT BED AT END OF FOXCROSS (2" VALVE REPLACEMENT) CORNER OF PONDSIDE AND MOSAIC PARK (2" VALVE REPLACEMENT) SOUTH SIDE OF THE ROAD ON BACKCREEK (HUNTER SINGLE STATION DECODER) NORTHSIDE OF THE ROAD BETWEEN PEPPERPIKE AND RIVERSTONE (HUNTER SINGLE STATION DECODER) TRAILMARK DRIVE SOUTH OF BACKCREEK PLANT BED (HUNTER SINGLE STATION DECODER) Six Mile CDD Trailmark Hunter ICD Single station decoder 2" valve 3M DBY-r Splice kits Misc. PVC pipe and fittings O&M-Irrigation maint	3,844.56

APPROVED
By Alex Boyer at 9:49 am, Jan 21, 2025

INVOICE

BrightView

Landscape Services

Sold To: 22539664
Six Mile CDD
475 W Town Pl Ste 114
St Augustine FL 32092

Customer #: 22539664
Invoice #: 9212085
Invoice Date: 1/20/2025
Sales Order: 8581771
Cust PO #:

Project Name: Six Mile CDD Trailmark: Valve replacement and Electrical troubleshooting

Project Description: Six Mile CDD Trailmark: Valve replacement and Electrical troubleshooting

Job Number	Description	Amount
	Labor (Two techs ten hours each)	
	Total Invoice Amount	3,844.56
	Taxable Amount	
	Tax Amount	
	Balance Due	3,844.56

Terms: Net 15 Days

If you have any questions regarding this invoice, please call

Please detach stub and remit with your payment

Payment Stub

Customer Account #: 22539664
Invoice #: 9212085
Invoice Date: 1/20/2025

Amount Due: \$ 3,844.56

Thank you for allowing us to serve you

Please reference the invoice # on your check and make payable to

Six Mile CDD
475 W Town Pl Ste 114
St Augustine FL 32092

BrightView Landscape Services, Inc.
P.O. Box 740655
Atlanta, GA 30374-0655

Elite Amenities NE FL, LLC

4116 Running Bear Lane
Saint Johns, FL 32259 US
+19047100172
eric@eliteamenities.com



INVOICE

BILL TO
Six Mile Creek CDD
6200 Lee Vista Blvd, Ste 300
Orlando, FL 32822

#173
Event Monitor
320 598-123

INVOICE 1783
DATE 01/13/2025
TERMS Due in 10 days
DUE DATE 01/23/2025

DATE	DESCRIPTION	QTY	RATE	AMOUNT
	Event: January 5th	5	28.01	140.05
	Event: January 11th	4	28.01	112.04
	Event: January 18th	6	28.01	168.06
	Event: January 25th	4	28.01	112.04

BALANCE DUE **\$532.19**



JAN 17 2025

Invoice 1150082ES Page 1 of 2
 Bill Group # 37224
 Statement Date 01/17/2025
 Current Charges \$18.25
 Balance Forward \$0.00
 Payment Due 02/10/2025

SIX MILE CREEK COMMUNITY DEVELOPMENT DISTRICT

801 TRAILMARK DR - Dec 24
St Augustine, FL 32092-0000

TECO Account Number: 211014091725

Details of Charges

Previous Balance	\$8.59
Payments Received	\$8.59 CR
Balance Forward	\$0.00

Current Gas Service Charges for January 2025

Gas Charge	\$10.41
(29 days @ \$0.526, 3 days @ \$0.524)	
Transportation	\$1.64
(19.8 Therms @ \$0.0827)	
Fuel	\$0.25
Customer Charge	\$5.95
Sales Taxes - County	\$0.00
Sales Taxes - State	\$0.00

Total Due by 02/10/2025 \$18.25

± 38
330.538 432

877-436-4427
 onlyfng.com
 customerservice@onlyfng.com

For Emergencies or Gas Leaks (24/7) Call TECO
1-877-832-6747

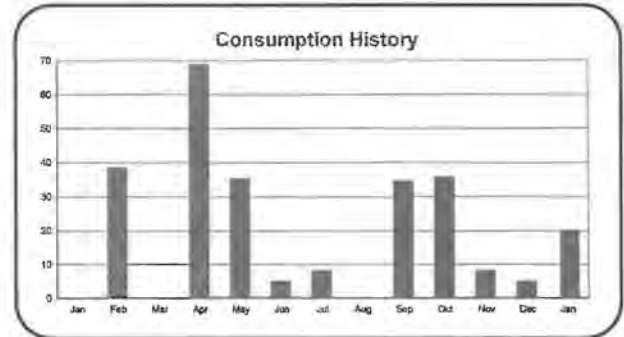

How We Calculated Your Charges

Meter Start	Meter End	Days of Service	Therms Used	Fuel Used	Fuel Rate	Fuel Charges	RatePerTherm	Gas Charges
12/03/2024	01/03/2025	32	19.8	0.47	\$0.5258	\$0.25	\$0.5258	\$10.41

Variable Rate: INSIDE FERC FGT Z3

The recent billing for your account may have been delayed. We apologize for any inconvenience. Please contact FNG customer service if you have any questions. Thank you for being a valued Florida Natural Gas customer.



PO BOX 570828
ATLANTA, GA 30357

Please tear off and return stub with your payment.

Bill Group # 37224
 Invoice # 1150082ES
 Total Due by 02/10/2025 \$18.25

Amount Enclosed (checks payable to FLORIDA NATURAL GAS)

\$ 18.25

To pay by ACH, please contact our Customer Care team at 877.436.4427

SIX MILE CREEK COMMUNITY DEVELOPMENT DISTRICT
 ACCOUNTS PAYABLE
 6200 LEE VISTA BLVD, STE 300
 ORLANDO, FL 32822-0000

FLORIDA NATURAL GAS
 P.O. BOX 934726
 ATLANTA, GA 31193-4726



SIX MILE CREEK COMMUNITY DEVELOPMENT DISTRICT

Invoice 1150082ES
Bill Group #
Statement Date
Current Charges
Balance Forward
Payment Due

Page 2 of 2
37224
01/17/2025
\$18.25
\$0.00
02/10/2025

Original



Hawkins, Inc.
2381 Rosegate
Roseville, MN 55113
Phone: (612) 331-6910

INVOICE

Total Invoice	\$1,077.42
Invoice Number	6966194
Invoice Date	1/20/25
Sales Order Number/Type	4715734 SL
Branch Plant	74
Shipment Number	5632305

Sold To: 484851
ACCOUNTS PAYABLE
SIX MILE CREEK CDD
6200 Lee Vista Blvd
Ste 300
Orlando FL 32822

Ship To: 495952
TRAIL MARK
805 Trailmark Dr
St Augustine FL 32092-7634

Net Due Date	Terms	FOB Description	Ship Via	Customer P.O.#	P.O. Release	Sales Agent #			
2/19/25	Net 30	PPD Origin	HWTG			381			
Line #	Item Number	Item Name/ Description	Tax	Qty Shipped	Trans UOM	Unit Price	Price UOM	Weight Net/Gross	Extended Price
1.001	699922	15 GA Blu/Black Deldrum DELDRM 1H1/X1.9/250	N	2.0000- 2.0000-	DD DD	\$15.0000	DD	20.0- 20.0-	LB GW (\$30.00)
Related Order #: 04325654									
1.002	699922	15 GA Blu/Black Deldrum DELDRM 1H1/X1.9/250	N	3.0000- 3.0000-	DD DD	\$15.0000	DD	30.0- 30.0-	LB GW (\$45.00)
Related Order #: 04355837									
1.003	699922	15 GA Blu/Black Deldrum DELDRM 1H1/X1.9/250	N	1.0000- 1.0000-	DD DD	\$15.0000	DD	10.0- 10.0-	LB GW (\$15.00)
Related Order #: 04377180									
2.000	41930	Azone - EPA Reg. No. 7870-1 1 LB BLK (Mini-Bulk)	N	275.0000 275.0000	GA GA	\$3.0000	GA	2,659.3 2,659.3	LB GW \$825.00
2.010	Fuel Surcharge	Freight	N	1.0000	EA	\$12.0000			\$12.00
3.000	42871	Sulfuric Acid 38-40% 15 GA DD	N	4.0000 4.0000	DD DD	\$67.6046	DD	648.0 688.0	LB GW \$270.42

Page 1 of 2

Tax Rate
0 %

Sales Tax
\$0.00

Invoice Total

Continued on next page

No Discounts on Freight
IMPORTANT: All products are sold without warranty of any kind and purchasers will, by their own tests, determine suitability of such products for their own use. Seller warrants that all goods covered by this invoice were produced in compliance with the requirements of the Fair Labor Standards Act of 1938, as amended. Seller specifically disclaims and excludes any warranty of merchantability and any warranty of fitness for a particular purpose.
NO CLAIMS FOR LOSS, DAMAGE OR LEAKAGE ALLOWED AFTER DELIVERY IS MADE IN GOOD CONDITION.

CHECK REMITTANCE:
Hawkins, Inc.
P.O. Box 860263
Minneapolis, MN 55486-0263

WIRING CONTACT INFORMATION:
Email: Credit.Dept@Hawkinsinc.com
Phone Number: (612) 331-6910
Fax Number: (612) 225-6702

FINANCIAL INSTITUTION:
US Bank
800 Nicollet Mall
Minneapolis, MN 55402

Account Name: Hawkins, Inc.
Account #: 180120759469
ABA/Routing #: 091000022
Swift Code#: USBKUS44IMT
Type of Account: Corporate Checking

ACH PAYMENTS:
CTX (Corporate Trade Exchange) is our preferred method. Please remember to include in the addendum the document numbers pertaining to the payment.
For other than CTX, the remit to information may be emailed to Credit.Dept@Hawkinsinc.com

CASH IN ADVANCE/EFT PAYMENTS:
Please list the Hawkins, Inc. sales order number or your purchase order number if the invoice has not been processed yet.

This contractor and subcontractor shall abide by the requirements of 41 CFR 5560-1.4(a), 60-300.5(a) and 60-741.5(a). These regulations prohibit discrimination against qualified individuals based on their status as protected veterans or individuals with disabilities, and prohibit discrimination against all individuals based on their race, color, religion, sex, or national origin. Moreover, these regulations require that covered prime contractors and subcontractors take affirmative action to employ and advance in employment individuals without regard to race, color, religion, sex, national origin, protected veteran status or disability.

Original



Hawkins, Inc.
2381 Rosegate
Roseville, MN 55113
Phone: (612) 331-6910

INVOICE

Total Invoice **\$1,077.42**
Invoice Number 6966194
Invoice Date 1/20/25
Sales Order Number/Type 4715734 SL
Branch Plant 74
Shipment Number 5632305

Line #	Item Number	Item Name/ Description	Tax	Qty Shipped	Trans UOM	Unit Price	Price UOM	Weight Net/Gross	Extended Price
Continued from previous page									
3.001	699922	15 GA Blu/Black Deldrum	N	4.0000	DD	\$15.0000	RD	40.0 LB	\$60.00
		DELDRM 1H1/X1.9/250		4.0000	RD			40.0 GW	

Related Order #: 04715734

***** Receive Your Invoice Via Email *****

Please contact our Accounts Receivable Department via email at Credit.Dept@HawkinsInc.com or call 612-331-6910 to get it setup on your account.

APPROVED
By Alex Boyer at 10:24 am, Jan 23, 2025

O&M-Pool chems

Page 2 of 2

Tax Rate Sales Tax
0 % \$0.00

Invoice Total **\$1,077.42**

No Discounts on Freight
IMPORTANT: All products are sold without warranty of any kind and purchasers will, by their own tests, determine suitability of such products for their own use. Seller warrants that all goods covered by this invoice were produced in compliance with the requirements of the Fair Labor Standards Act of 1938, as amended. Seller specifically disclaims and excludes any warranty of merchantability and any warranty of fitness for a particular purpose.
NO CLAIMS FOR LOSS, DAMAGE OR LEAKAGE ALLOWED AFTER DELIVERY IS MADE IN GOOD CONDITION.

CHECK REMITTANCE:
Hawkins, Inc.
P.O. Box 860263
Minneapolis, MN 55486-0263

WIRING CONTACT INFORMATION:
Email: Credit.Dept@HawkinsInc.com

Phone Number: (612) 331-6910
Fax Number: (612) 225-6702

FINANCIAL INSTITUTION:
US Bank
800 Nicollet Mall
Minneapolis, MN 55402

Account Name: Hawkins, Inc.
Account #: 180120759469
ABA/Routing #: 091000022
Swift Code#: USBKUS44IMT
Type of Account: Corporate Checking

ACH PAYMENTS:
CTX (Corporate Trade Exchange) is our preferred method. Please remember to include in the addendum the document numbers pertaining to the payment.
For other than CTX, the remit to information may be emailed to Credit.Dept@HawkinsInc.com

CASH IN ADVANCE/EFT PAYMENTS:
Please list the Hawkins, Inc. sales order number or your purchase order number if the invoice has not been processed yet.

This contractor and subcontractor shall abide by the requirements of 41 CFR §§60-1.4(a), 60-300.5(a) and 60-741.5(a). These regulations prohibit discrimination against qualified individuals based on their status as protected veterans or individuals with disabilities, and prohibit discrimination against all individuals based on their race, color, religion, sex, or national origin. Moreover, these regulations require that covered prime contractors and subcontractors take affirmative action to employ and advance in employment individuals without regard to race, color, religion, sex, national origin, protected veteran status or disability.

KUTAK ROCK LLP

TALLAHASSEE, FLORIDA

Telephone 404-222-4600

Facsimile 404-222-4654

Federal ID 47-0597598

January 14, 2025

#181
210-317-311

Mr. Jim Oliver
Six Mile Creek CDD
Governmental Management Services – St. Augustine
Suite 114
475 West Town Place
St. Augustine, FL 32092

Check Remit To:

Kutak Rock LLP

PO Box 30057

Omaha, NE 68103-1157

ACH/Wire Transfer Remit To:

ABA #

First National Bank of Omaha

Kutak Rock LLP

A/C #

Reference: Invoice No. 3512048

Client Matter No. 18323-1

Notification Email: eftgroup@kutakrock.com



Invoice No. 3512048

18323-1

Re: Six Mile Creek CDD - General Counsel

For Professional Legal Services Rendered

10/01/24	W. Haber	0.80	188.00	Prepare for and participate in staff call to discuss agenda for October meeting
10/08/24	W. Haber	0.60	141.00	Prepare addendum to landscape maintenance RFP; confer with Sweeting and Kern regarding same
10/14/24	K. Jusevitch	0.70	87.50	Review annual agency invoice; prepare ancillary ratification resolution and confer with Haber regarding same
10/16/24	W. Haber	0.70	164.50	Review and respond to inquiry regarding addenda for landscape maintenance RFP; confer with Oliver regarding agreement with Alosant; prepare response to Notice to Owner
10/16/24	K. Jusevitch	0.20	25.00	Correspond with district manager regarding meeting documents
10/18/24	W. Haber	0.60	141.00	Review addendum to Landscape Maintenance RFP; confer with Sweeting regarding same; review proposed revisions to license agreement

KUTAK ROCK LLP

Six Mile Creek CDD

January 14, 2025

Client Matter No. 18323-1

Invoice No. 3512048

Page 2

10/23/24	W. Haber	0.30	70.50	Review and revise revisions to license agreement for lake use
10/24/24	K. Haber	0.60	153.00	Research towing requirements for boat and trailer
10/25/24	W. Haber	0.30	70.50	Confer with Sweeting regarding license agreement and revision to agenda to include same
10/28/24	W. Haber	0.50	117.50	Participate in conference call regarding agenda for November meeting; confer with staff regarding towing authority for common areas
10/28/24	K. Jusevitch	2.40	300.00	Review landscaping RFP responses and prepare summary; confer with Haber regarding same
10/29/24	W. Haber	0.50	117.50	Review RFP responses and confer with Kern and Sweeting regarding same
10/31/24	W. Haber	0.90	211.50	Review and revise license agreement for recreation pond; prepare addendum to landscape maintenance RFP and confer with Kern and Sweeting regarding same
11/01/24	W. Haber	3.60	846.00	Prepare for and participate in Board meeting
11/05/24	W. Haber	0.40	94.00	Review and revise RFP award letters for landscape maintenance contract
11/05/24	K. Jusevitch	1.00	125.00	Prepare award letters for landscaping proposals; confer with Haber regarding same
11/07/24	W. Haber	0.40	94.00	Confer with Sweeting regarding status of award notices for RFP; begin preparation of agreement with BrightView
11/13/24	K. Jusevitch	0.80	100.00	Prepare landscaping agreement; confer with Haber regarding same
11/19/24	W. Haber	0.20	47.00	Review agenda for November meeting
11/20/24	W. Haber	0.80	188.00	Prepare for and participate in conference call to discuss agenda and related matters for November meeting; review and revise landscape maintenance agreement

KUTAK ROCK LLP

Six Mile Creek CDD

January 14, 2025

Client Matter No. 18323-1

Invoice No. 3512048

Page 3

11/20/24	K. Jusevitch	0.20	25.00	Confer with Haber regarding landscaping agreement
11/25/24	W. Haber	0.40	94.00	Prepare for Board meeting; confer with Oliver regarding same
11/25/24	K. Jusevitch	0.40	50.00	Confer with Haber regarding new supervisor information and agenda documents
11/26/24	W. Haber	2.80	658.00	Prepare for and participate in Board meeting

TOTAL HOURS 20.10

TOTAL FOR SERVICES RENDERED \$4,108.50

DISBURSEMENTS

Freight and Postage	0.69
Meals	7.18
Travel Expenses	172.66

TOTAL DISBURSEMENTS 180.53

TOTAL CURRENT AMOUNT DUE \$4,289.03

Keen On Klean
 5783 Mining Ter Ste 5
 Jacksonville, FL 32257 US
 +19047489060
 info@KeenonKlean.com
 www.KeenOnKlean.com

APPROVED
 By Alex Boyer at 10:59 am, Jan 16, 2025



Keen on Klean
 Cleaning services

Amenity-Janitorial

INVOICE

#214
 320-588-487

BILL TO
 Six Mile Creek CDD
 1408 Hamlin Ave Unit E
 St Cloud, FL 34771



INVOICE # 8670
DATE 01/15/2025
DUE DATE 01/15/2025
TERMS Due on receipt

DATE	ACTIVITY	QTY	RATE	AMOUNT	PM & SQ FT
	Monthly Janitorial Service JANUARY 2025 JANITORIAL CLEANING- 805 TrailMark Drive St Augustine, FL 32092	1	2,945.00	2,945.00	

We appreciate your unwavering support. The invoice is being delivered early due to the upcoming holiday season

SUBTOTAL	2,945.00
TAX	0.00
TOTAL	2,945.00
BALANCE DUE	\$2,945.00

Onplace LLC

6801 Energy Ct
Ste 201
Lakewood Ranch, FL 34240-8584
+19417062637
monstad@onplace.life
www.onplace.life



INVOICE

BILL TO
Six Mile Creek CDD
475 West Town Place
Suite 114
St. Augustine, FL 32092



INVOICE 1625
DATE 01/22/2025
TERMS Net 15
DUE DATE 02/06/2025

PO NUMBER
TrailMark

#222 320-518-122

DATE	ACTIVITY	DESCRIPTION	QTY	RATE	AMOUNT
12/13/2024	Passthrough Payroll Wages	Onsite Amenity Jan 23 Prepay Wages	1	9,500.00	9,500.00
12/13/2024	Passthrough Payroll Wages	Additional Payroll Jan 23 Balance Due for Payroll	1	236.12	236.12

We have mixed! See the attached W9

BALANCE DUE

\$9,736.12

New Address:
6801 Energy Ct Ste 201
Lakewood Ranch, FL 34240
Please reach out to ESteele@onplace.life with any questions.

RealManage
P.O. Box 803555
Dallas, TX 75380-3555

#286 hnd
320-578-121

INVOICE

Date	10/15/2024
Invoice #	ONSITE-2024BM19-SIXMICDD
Account Number	SIXMICDD
Total Amount	\$2,541.00
Total Due	\$2,541.00

Six Mile CDD

Contact RealManage toll free at 214-269-2520

JAN 21 2025

Invoice Description: Monthly Onsite Billing: 10/01/2024 - 10/15/2024

Description/Memo	Charge
Monthly Onsite Billing: REASONOVER, SKIP Regular Paid 10/15 Paycheck: 9/23-10/7 Period	\$1,694.00
Monthly Onsite Billing: REASONOVER, SKIP Regular Paid 10/15 Paycheck: 9/23-10/7 Period - Admin Fee	\$847.00
Total:	\$2,541.00

THANK YOU FOR YOUR BUSINESS!

▼ Please tear off and return with your payment. ▼

Account No. SIXMICDD **Amount Due:** \$2,541.00
Invoice No. ONSITE-2024BM19-SIXMICDD **Due Date:** 10/15/2024
Six Mile CDD

Make check payable to:

RealManage
P.O. Box 803555
Dallas, TX 75380-3555

RealManage
P.O. Box 803555
Dallas, TX 75380-3555

#286nd
20-538-121

INVOICE

Date	10/31/2024
Invoice #	ONSITE-2024BM20-SIXMICDD
Account Number	SIXMICDD
Total Amount	\$2,252.25
Total Due	\$2,252.25

Six Mile CDD

Contact RealManage toll free at 214-269-2520



Invoice Description: Monthly Onsite Billing: 10/16/2024 - 10/31/2024

Description/Memo	Charge
Monthly Onsite Billing: REASONOVER, SKIP Regular Paid 10/31 Paycheck: 10/8-10/22 Period - Admin Fee	\$750.75
Monthly Onsite Billing: REASONOVER, SKIP Regular Paid 10/31 Paycheck: 10/8-10/22 Period	\$1,501.50
Total:	\$2,252.25

THANK YOU FOR YOUR BUSINESS!

▼ Please tear off and return with your payment. ▼

Account No. SIXMICDD **Amount Due:** \$2,252.25
Invoice No. ONSITE-2024BM20-SIXMICDD **Due Date:** 10/31/2024
Six Mile CDD

Make check payable to:

RealManage
P.O. Box 803555
Dallas, TX 75380-3555

RealManage
P.O. Box 803555
Dallas, TX 75380-3555

#286 nel
20578 121

INVOICE

Date	11/15/2024
Invoice #	ONSITE-2024BM21-SIXMICDD
Account Number	SIXMICDD
Total Amount	\$2,994.75
Total Due	\$2,994.75

Six Mile CDD

Contact RealManage toll free at 214-269-2520

Invoice Description: Monthly Onsite Billing: 11/01/2024 - 11/15/2024



Description/Memo	Charge
Monthly Onsite Billing: REASONOVER, SKIP Regular Paid 11/15 Paycheck: 10/23-11/7 Period - Admin Fee	\$998.25
Monthly Onsite Billing: REASONOVER, SKIP Regular Paid 11/15 Paycheck: 10/23-11/7 Period	\$1,996.50
Total:	\$2,994.75

THANK YOU FOR YOUR BUSINESS!

▼ Please tear off and return with your payment. ▼

Account No. SIXMICDD **Amount Due:** \$2,994.75
Invoice No. ONSITE-2024BM21-SIXMICDD **Due Date:** 11/15/2024
Six Mile CDD

Make check payable to:

RealManage
P.O. Box 803555
Dallas, TX 75380-3555

RealManage
P.O. Box 803555
Dallas, TX 75380-3555

#286 hed
320-538-121

INVOICE

Date	11/30/2024
Invoice #	ONSITE-2024BM22-SIXMICDD
Account Number	SIXMICDD
Total Amount	\$2,656.50
Total Due	\$2,656.50

Six Mile CDD

Contact RealManage toll free at 214-269-2520

Invoice Description: Monthly Onsite Billing: 11/16/2024 - 11/30/2024



Description/Memo	Charge
Monthly Onsite Billing: REASONOVER, SKIP Regular Paid 11/30 Paycheck: 11/8-11/22 Period - Admin Fee	\$885.50
Monthly Onsite Billing: REASONOVER, SKIP Regular Paid 11/30 Paycheck: 11/8-11/22 Period	\$1,771.00
Total:	\$2,656.50

THANK YOU FOR YOUR BUSINESS!

▼ Please tear off and return with your payment. ▼

Account No. SIXMICDD **Amount Due:** \$2,656.50
Invoice No. ONSITE-2024BM22-SIXMICDD **Due Date:** 11/30/2024
Six Mile CDD

Make check payable to:

RealManage
P.O. Box 803555
Dallas, TX 75380-3555

RealManage
P.O. Box 803555
Dallas, TX 75380-3555

#286 ^{hd}
320-598-121

INVOICE

Date	12/15/2024
Invoice #	ONSITE-2024BM23-SIXMICDD
Account Number	SIXMICDD
Total Amount	\$2,013.00
Total Due	\$2,013.00

Six Mile CDD

Contact RealManage toll free at 214-269-2520

Invoice Description: Monthly Onsite Billing: 12/01/2024 - 12/15/2024



Description/Memo	Charge
Monthly Onsite Billing: REASONOVER, SKIP Regular Paid 12/15 Paycheck: 11/23-12/7 Period - Admin Fee	\$495.00
Monthly Onsite Billing: REASONOVER, SKIP Regular Paid 12/15 Paycheck: 11/23-12/7 Period	\$990.00
Monthly Onsite Billing: REASONOVER, SKIP Holiday Paid 12/15 Paycheck: 11/23-12/7 Period - Admin Fee	\$176.00
Monthly Onsite Billing: REASONOVER, SKIP Holiday Paid 12/15 Paycheck: 11/23-12/7 Period	\$352.00
Total:	\$2,013.00

THANK YOU FOR YOUR BUSINESS!

▼ Please tear off and return with your payment. ▼

Account No. SIXMICDD **Amount Due:** \$2,013.00
Invoice No. ONSITE-2024BM23-SIXMICDD **Due Date:** 12/15/2024
Six Mile CDD

Make check payable to:

RealManage
P.O. Box 803555
Dallas, TX 75380-3555

RealManage
P.O. Box 803555
Dallas, TX 75380-3555

INVOICE

Date	12/31/2024
Invoice #	ONSITE-2024BM24-SIXMICDD
Account Number	SIXMICDD
Total Amount	\$2,392.50
Total Due	\$2,392.50

286 ^{ml}
320 598 121

Six Mile CDD

Contact RealManage toll free at 214-269-2520



Invoice Description: Monthly Onsite Billing: 12/16/2024 - 12/31/2024

Description/Memo	Charge
Monthly Onsite Billing: REASONOVER, SKIP Regular Paid 12/31 Paycheck: 12/8-12/22 Period - Admin Fee	\$797.50
Monthly Onsite Billing: REASONOVER, SKIP Regular Paid 12/31 Paycheck: 12/8-12/22 Period	\$1,595.00
Total:	\$2,392.50

THANK YOU FOR YOUR BUSINESS!

▼ Please tear off and return with your payment. ▼

Account No. SIXMICDD

Amount Due: \$2,392.50

Invoice No. ONSITE-2024BM24-SIXMICDD

Due Date: 12/31/2024

Six Mile CDD

Make check payable to:

RealManage

P.O. Box 803555
Dallas, TX 75380-3555

TURNER WGV LLC
 6205 STATE ROAD 16
 ST. AUGUSTINE FL 32094

PHONE: (904) 907-2424

RECEIVED
 JAN 22 2025

CUST NO: 4055 JOB NO: 000 PURCHASE ORDER: REFERENCE: TERMS: NET 20TH CLERK: ACP DATE / TIME: 1/17/25 11:22

DUE DATE: 2/20/25 TERMINAL: 405

SOLD TO:
 SIX MILE CREEK COMMUNITY
 6200 Lee Vista Blvd, St 300
 Orlando FL 32822
 877-221-6919

SHIP TO:
 #245
 330538 46

TAX: WGV DEFAULT TAX CODE ST4

INVOICE: 9683 /4

SKU	MFG PART #	DESCRIPTION	SUGG	UNITS	PRICE /PER	EXTENSION
3926235	OM60DM950CAGU2	LED A19 GU24 DL 60W	7.99	1	7.99 EA	7.99 N
5293394	01-3430-138	PULL UTILITY 6-1/2" BLK	6.59	1	6.59 EA	6.59 N
3926235	OM60DM950CAGU2	LED A19 GU24 DL 60W	7.99	1	7.99 EA	7.99 N
5293394	01-3430-138	PULL UTILITY 6-1/2" BLK	6.59	1	6.59 EA	6.59 N
3926235	OM60DM950CAGU2	LED A19 GU24 DL 60W	7.99	2	7.99 EA	15.98 N
<div style="border: 1px solid black; padding: 5px; display: inline-block;"> <p>APPROVED By Alex Boyer at 11:30 am, Jan 17, 2025</p> </div>						
<p>Amenity-repairs</p>						

(ALEX BOYER)
 ** AMOUNT CHARGED TO STORE ACCOUNT **

TAXABLE 0.00
 NON-TAXABLE 45.14
 SUBTOTAL 45.14

TAX AMOUNT 0.00
TOTAL 45.14

TOT WT: 1.20

[Signature]
 Received By

INVOICE



Sold To: 22539664
Six Mile CDD
475 W Town Pl Ste 114
St Augustine FL 32092

Customer #: 22539664
Invoice #: 9217316
Invoice Date: 1/24/2025
Sales Order: 8586222
Cust PO #:

RECEIVED
JAN 24 2025

Project Name: Six Mile - Oak tree install
Project Description: enhancement

Job Number	Description	Amount
460800520	Six Mile CDD Trailmark 42 Patina Pl- Oak install	930.52
	<div style="border: 1px solid black; padding: 5px; display: inline-block;"> APPROVED <i>By Alex Boyer at 3:30 pm, Jan 27, 2025</i> </div>	
	O&M-landscape cont	
	#170 220-516 466	
	Total Invoice Amount	930.52
	Taxable Amount	
	Tax Amount	
	Balance Due	930.52

Terms: Net 15 Days

If you have any questions regarding this invoice, please call

Please detach stub and remit with your payment

Payment Stub

Customer Account #: 22539664
Invoice #: 9217316
Invoice Date: 1/24/2025

Amount Due: \$ 930.52

Thank you for allowing us to serve you

Please reference the invoice # on your check and make payable to

Six Mile CDD
475 W Town Pl Ste 114
St Augustine FL 32092

BrightView Landscape Services, Inc.
P.O. Box 740655
Atlanta, GA 30374-0655

Disclosure Services LLC

1005 Bradford Way
Kingston, TN 37763

Invoice

Date	Invoice #
1/22/2025	22

Bill To
Six Mile Creek CDD c/o GMS, LLC



#96
Rev. Ser
310.17.38

Terms	Due Date
Net 30	2/21/2025

Description	Amount
Amortization Schedule Series 2017A 2-1-25 Prepay \$30,000	250.00
Amortization Schedule Series 2020 AA3 PH3A 2-1-25 Prepay \$5,000	100.00
Amortization Schedule Series 2021 2-1-25 Prepay \$5,000	100.00

--

Total	\$450.00
Payments/Credits	\$0.00
Balance Due	\$450.00

Phone #
865-717-0976

E-mail
tcarter@disclosureservices.info



Pay by Phone (844) 752-8845
Phone (904) 209-2700
Fax (904) 209-2718
Toll Free (877) 837-2311

PO Drawer 3006
St. Augustine, FL 32085

Statement Date 01/19/2025	Current Charges Due Date 02/18/2025
-------------------------------------	---

Current Month Activity

Services Dates	Service Description	Units	Amount	Total
12/19/24	Amount of Your Last Statement			2,658.25
1/14/25	Payment - Thank You		-2,658.25	
	Past Due Balance			0.00
Water Rates				
	Meter Maintenance Charge	9.00	1.00	9.00
	Base Rate	123.52	1.00	123.52
Consumption Fees	0 - 40,000 Gallons	3.92	40.00	156.80
	40,001 - 80,000 Gallons	4.89	40.00	195.60
	80,001 - 160,000 Gallons	8.25	80.00	660.00
	160,001 + Gallons	11.29	28.10	317.25
	Water Total		188.10	1,462.17
Wastewater Rates				
	Base Rate	145.10	1.00	145.10
Consumption Fees	0 + Sewer Gallons	6.83	188.10	1,284.72
	Wastewater Total		188.10	1,429.82
	Past Due Balance			0.00
	Current Charges			2,891.99
	Amount Now Due / Credits			2,891.99

SIX MILE CREEK CDD/TRAILMARK SUBDIVISION

Account Number:
556887-132900

Service Address:
805 TRAILMARK DR

Service Type:
Commercial

Days in Billing Cycle: 31

Deposit Amount: \$ 0.00

Deposit Date:

Geo Code: WGV

Meter Number: 77848570
Present Read Date: 01/19/2025
Previous Read Date: 12/19/2024
Current Reading: 1545960
Previous Reading: 1527150
Gallons Used: 188,100.00

#24
300-538-431



Past Due Balances are subject to a Late Fee of 1.5% or \$5.00, whichever is greater and disconnection of service if not paid.

MESSAGE CENTER

In 2023, SJCUD detected 13 contaminants in the drinking water. All contaminants were at allowable levels & no health based violations were reported. Please go to www.sjcul.com/WaterReport/NorthWest.pdf to view you report. This report contains important info about the source & quality of your water. To receive a hard copy of the report or if you have any questions please call 904-209-2700.

www.sjcutility.us

See reverse for monthly draft options or credit card payments.

Please detach and return with your payment.

FL29539F



ST JOHNS COUNTY UTILITY DEPARTMENT
POST OFFICE DRAWER 3006
ST AUGUSTINE FL 32085-3006

Account Number		Date Due	
556887-132900		02/18/2025	
Past Due Amount	Current Charges/Credits	Amount Now Due	After Due Date Pay
0.00	2,891.99	2,891.99	2,935.37
Please Enter Amount Paid \$		2891.99	



Please write your account number on your check and remit to:

ST JOHNS COUNTY UTILITY DEPARTMENT
POST OFFICE DRAWER 3006
ST AUGUSTINE FL 32085-3006



*****AUTO**MIXED AADC 302

SIX MILE CREEK CDD/TRAILMARK SUBDIVISION
6200 LEE VISTA BLVD STE 300 3454
ORLANDO FL 32822-5149

000000132900000000556887000000289199000000293537

Check for Address Change



Pay by Phone (844) 752-8845
 Phone (904) 209-2700
 Fax (904) 209-2718
 Toll Free (877) 837-2311

PO Drawer 3006
 St. Augustine, FL 32085

Statement Date 01/19/2025	Current Charges Due Date 02/18/2025
-------------------------------------	---

Current Month Activity

Services Dates	Service Description	Units	Amount	Total
12/19/24	Amount of Your Last Statement			38.60
1/14/25	Payment - Thank You		-38.60	
	Past Due Balance			0.00
	Water Rates			
	Base Rate	38.60	1.00	38.60
Consumption Fees	0 - 12,500 Gallons	3.92		0.00
	Water Total			38.60
	Past Due Balance			0.00
	Current Charges			38.60
	Amount Now Due / Credits			38.60

SIX MILE CREEK CDD/TRAILMARK SUBDIVISION

Account Number:
556887-135864

Service Address:
295 BACK CREEK DR

Service Type:

Commercial

Days in Billing Cycle: 31

Deposit Amount: \$ 0.00

Deposit Date:

Geo Code: WGV

Meter Number: 86147234

Present Read Date: 01/19/2025

Previous Read Date: 12/19/2024

Current Reading: 173

Previous Reading: 173

Gallons Used: 0.00

#24
 330-578-4771



Past Due Balances are subject to a Late Fee of 1.5% or \$5.00, whichever is greater and disconnection of service if not paid.

MESSAGE CENTER

In 2023, SJCUD detected 13 contaminants in the drinking water. All contaminants were at allowable levels & no health based violations were reported. Please go to www.sjcf.us/WaterReport/NorthWest.pdf to view you report. This report contains important info about the source & quality of your water. To receive a hard copy of the report or if you have any questions please call 904-209-2700.

www.sjcutility.us

See reverse for monthly draft options or credit card payments.

Please detach and return with your payment.

FL29539F



ST JOHNS COUNTY UTILITY DEPARTMENT
 POST OFFICE DRAWER 3006
 ST AUGUSTINE FL 32085-3006

Account Number 556887-135864		Date Due 02/18/2025	
Past Due Amount	Current Charges/Credits	Amount Now Due	After Due Date Pay
0.00	38.60	38.60	43.60
Please Enter Amount Paid \$		38.60	



Please write your account number on your check and remit to:

ST JOHNS COUNTY UTILITY DEPARTMENT
 POST OFFICE DRAWER 3006
 ST AUGUSTINE FL 32085-3006



SIX MILE CREEK CDD/TRAILMARK SUBDIVISION
 6200 LEE VISTA BLVD STE 300
 ORLANDO FL 32822-5149

000000135864000000556887000000003860000000004360

Check for Address Change

Invoice # 0008



#249
300-1SS-1

Gary Whitaker
131 Seasons Court
St. Augustine Florida, 32092

www.strictlyentertainmentdis.com

This agreement shall cover the disc jockey performance at the following affair:

Date Of Event: Sunday February 9, 2025

Type Of Event: Super Bowl Party

Hours Of Music: 3:00 – 6:00

Additional services: N/A

Location Of Event: Trailmark welcome center parking lot

Client (s) Name: Six Mile Creek CDD – Attention: Board Of Directors

Address: 475 West Town Place, Suite # 114, St Augustine, Fl, 32092

Phone number:

Email address:

Deposit: None - Non refundable and all personal checks or money orders are made payable to “Gary Whitaker” only.

Balance : \$300.00 - The Balance is due on February 9, 2025. Final payment must be in the form of cash, check, money order and all checks or money orders are made payable to “Gary Whitaker”.

Guest Total:

DJ Gary Whitaker

Date: January 28, 2025

Client

Date:

131 Seasons Court, St Augustine Fl, 32092 <914.443.9115 > djgary22@hotmail.com

Please return (1) copy of invoice and deposit by the date of _____ to secure date*****

**REQUISITION NO. 172
SIX MILE CREEK COMMUNITY DEVELOPMENT DISTRICT
(ST. JOHNS COUNTY, FLORIDA)**

**\$8,250,000
CAPITAL IMPROVEMENT AND
REFUNDING REVENUE BOND SERIES
2021 (Assessment Area 2, Phase 3B)
A/C 226000005**

The undersigned, a Responsible Officer of Six Mile Creek Community Development District (the "District") hereby submits the following requisition for disbursement under and pursuant to the terms of the Master Trust Indenture from the District to U. S. Bank National Association, as trustee (the "Trustee"), dated as of July 1, 2007, as supplemented by a Ninth Supplemental Trust Indenture, dated as of November 1, 2021 (collectively, the "Indenture"; all capitalized terms used herein shall have the meaning ascribed to such term in the Indenture):

- (A) Requisition Number: 172
- (B) Name of Payee: ETM
First Citizens
ABA Routing #
Jacksonville, FL
Account # - England, Thims & Miller, Inc.
- (C) Amount Payable: Total: \$ 670.00
- (D) Purpose for which paid or incurred (refer also to specific contract if amount is due and payable pursuant to a contract involving progress payments, or, state Costs of Issuance, if applicable: Master Site Planning (WA#51) Invoice 216447 (October 2024)
- (E) Fund or Account from which disbursement to be made:

Capital Improvement and Refunding Revenue Bond Series 2021 (Assessment Area 2, Phase 3B)

The undersigned hereby certifies that:

1. obligations in the stated amount set forth above have been incurred by the District,
2. each disbursement set forth above is a proper charge against the Phase 1 Acquisition and Construction Account;
3. each disbursement set forth above was incurred in connection with the acquisition and/or construction of the Project;

4. each disbursement represents a Cost of the Project which has not previously been paid.

The undersigned hereby further certifies that there has not been filed with or served upon the District notice of any lien, right to lien, or attachment upon, or claim affecting the right to receive payment of, any of the moneys payable to the Payee set forth above, which has not been released or will not be released simultaneously with the payment hereof.

The undersigned hereby further certifies that such requisition contains no item representing payment on account of any retained percentage which the District is at the date of such certificate entitled to retain.

Attached hereto are originals of the invoice(s) from the vendor of the property acquired or the services rendered with respect to which disbursement is hereby requested.

**SIX MILE CREEK COMMUNITY
DEVELOPMENT DISTRICT**

By: _____

Chairperson, Board of Supervisors

CONSULTING ENGINEER'S APPROVAL

The undersigned Consulting Engineer hereby certifies that this disbursement is for a Cost of the Project and is consistent with: (i) the applicable acquisition or construction contract; (ii) the plans and specifications for the portion of the Project with respect to which such disbursement is being made; and (iii) the report of the Consulting Engineer, as such report shall have been amended or modified on the date hereof.

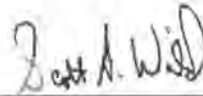

Consulting Engineer



Six Mile Creek Community Development District
6200 Lee Vista Boulevard Ste 300
Orlando, FL 32822

October 30, 2024

Invoice No: 216447

Total This Invoice \$670.00

Project 20291.00000 Master Site Planning (WA#51)

Professional Services rendered through October 26, 2024

Phase 01 Master Site Planning

Billing Limits

	Current	Prior	To-Date
Total Billings	0.00	27,338.50	27,338.50
Limit			35,000.00
Remaining			7,661.50

Total this Phase 0.00

Phase 02. Master Planning Coordination Meetings

Labor

	Hours	Rate	Amount
Executive VP/Chief Engineer			
Wild, Scott 10/5/2024	1.00	335.00	335.00
Wild, Scott 10/26/2024	1.00	335.00	335.00
Totals	2.00		670.00

Total Labor 670.00

Billing Limits

	Current	Prior	To-Date
Total Billings	670.00	32,762.50	33,432.50
Limit			50,000.00
Remaining			16,567.50

Total this Phase \$670.00

Phase XP Expenses

Total this Phase 0.00

Total This Invoice \$670.00

Outstanding Invoices

Number	Date	Balance
215971	10/3/2024	1,415.00
Total		1,415.00

Total Now Due \$2,085.00

REQUISITION NO. 92
(2023 Acquisition and Construction Account)

SIX MILE CREEK COMMUNITY DEVELOPMENT DISTRICT
(ST. JOHNS COUNTY, FLORIDA)

\$10,515,000
Capital Improvement Revenue Bonds
Series 2023 (2023 Project Area)

The undersigned, an Authorized Officer of Six Mile Creek Community Development District (the "District") hereby submits the following requisition for disbursement under and pursuant to the terms of the Master Trust Indenture from the District to U.S. Bank Trust Company, National Association, as successor trustee (the "Trustee"), dated as of July 1, 2007 (the "Master Indenture"), as amended and supplemented by the Eleventh Supplemental Trust Indenture between the District and Trustee, dated as of June 1, 2023 (the Master Indenture as amended and supplemented is hereinafter referred to as the "Indenture") (all capitalized terms used herein shall have the meaning ascribed to such term in the Indenture):

- (A) Requisition Number: **92**
- (B) Name of Payee: **ETM**
First Citizens
ABA Routing #
Jacksonville, FL
Account # - England, Thims & Miller, Inc
- (C) Amount Payable: **\$ 12,522.99**
- (D) Purpose for which paid or incurred (refer also to specific contract if amount is due and payable pursuant to a contract involving progress payments, or, state Costs of Issuance, if applicable):

Trailmark East Parcel - Phase 3 CEI (WA#73) Invoice 216453 (October 2024)

- (E) Fund or Account and subaccount, if any, from which disbursement is to be made:

\$ 12,522.99 Assessment Area 2 – Phase 3C Subaccount

\$ _____ Assessment Area 3 – Phase 3 Subaccount

The undersigned hereby certifies that obligations in the stated amount set forth above have been incurred by the District, that each disbursement set forth above is a proper charge against the 2023 Acquisition and Construction Account and the subaccount, if any, referenced above, that each disbursement set forth above was incurred in connection with the acquisition and construction of the 2023 Project and each represents a Cost of the 2023 Project, and has not previously been paid.

The undersigned hereby further certifies that there has not been filed with or served upon the District notice of any lien, right to lien, or attachment upon, or claim affecting the right to receive payment of, any of the moneys payable to the Payee set forth above, which has not been released or will not be released simultaneously with the payment hereof.

The undersigned hereby further certifies that such requisition contains no item representing payment on account of any retained percentage which the District is at the date of such certificate entitled to retain.

If this requisition is for a disbursement from other than the Costs of Issuance Account or for payment of capitalized interest, there shall be attached a resolution of the Governing Body of the District approving this requisition or approving the specific contract with respect to which disbursements pursuant to this requirement are due and payable.

Attached hereto are originals of the invoice(s) from the vendor of the property acquired or the services rendered with respect to which disbursement is hereby requested.

**SIX MILE CREEK COMMUNITY
DEVELOPMENT DISTRICT**

By: _____
Gregg F. Kern
Chairperson, Board of Supervisors

**CONSULTING ENGINEER'S APPROVAL FOR NON-COST OF ISSUANCE AND
CAPITALIZED INTEREST REQUESTS ONLY**

If this requisition is for a disbursement from other than Capitalized Interest or Costs of Issuance, the undersigned Consulting Engineer hereby certifies that this disbursement is for a Cost of the 2023 Project and is consistent with: (i) the applicable acquisition or construction contract; (ii) the plans and specifications for the portion of the 2023 Project with respect to which such disbursement is being made; and, (iii) the report of the Consulting Engineer attached as an Exhibit to the Eleventh Supplemental Trust Indenture, as such report shall have been amended or modified on the date hereof.

By: Scott A. Wild
Consulting Engineer



Six Mile Creek Community Development District
6200 Lee Vista Boulevard Ste 300
Orlando, FL 32822

October 30, 2024

Invoice No: 216453

Total This Invoice \$12,522.99

Project 21407.01000 TrailMark East Parcel - Phase 3 CEI (WA #73)

Professional Services rendered through October 26, 2024

Phase 01. CEI Services

Labor

			Hours	Rate	Amount
Executive VP/Chief Engineer					
Wild, Scott	10/26/2024		1.00	335.00	335.00
CEI Project Manager/Project Admin.					
Donchez, James	10/5/2024		.50	184.00	92.00
Donchez, James	10/12/2024		.25	184.00	46.00
Donchez, James	10/19/2024		.50	184.00	92.00
CEI Sr. Inspector					
Brooks, Jeffrey	10/12/2024		1.00	163.00	163.00
Brooks, Jeffrey	10/19/2024		5.00	163.00	815.00
CEI Inspector					
Jones, Joshua	10/12/2024		1.00	132.00	132.00
Lanh, Pong	10/5/2024		12.50	132.00	1,650.00
Lanh, Pong	10/12/2024		13.50	132.00	1,782.00
Lanh, Pong	10/19/2024		19.50	132.00	2,574.00
Lanh, Pong	10/26/2024		16.50	132.00	2,178.00
Steeple, Travis	10/12/2024		5.00	132.00	660.00
Totals			76.25		10,519.00
Total Labor					10,519.00

Billing Limits

	Current	Prior	To-Date
Total Billings	10,519.00	89,159.50	99,678.50
Limit			100,000.00
Remaining			321.50

Total this Phase \$10,519.00

Phase 02. Progress Meetings

Labor

			Hours	Rate	Amount
Executive VP/Chief Engineer					
Wild, Scott	10/26/2024		1.00	335.00	335.00

Engineer

Hebb, Cara	10/5/2024	3.25	175.00	568.75
Hebb, Cara	10/12/2024	.50	175.00	87.50
Hebb, Cara	10/19/2024	.25	175.00	43.75
Hebb, Cara	10/26/2024	.25	175.00	43.75

Totals 5.25 1,078.75

Total Labor 1,078.75

Billing Limits

	Current	Prior	To-Date
Total Billings	1,078.75	22,007.50	23,086.25
Limit			50,512.00
Remaining			27,425.75

Total this Phase \$1,078.75

Phase 03. Owner Requested Plan Revisions

Labor

		Hours	Rate	Amount
Engineering/Landscape Designer				
Jeter, Matthew	10/5/2024	1.00	140.00	140.00
Totals		1.00		140.00

Total Labor 140.00

Billing Limits

	Current	Prior	To-Date
Total Billings	140.00	6,734.50	6,874.50
Limit			10,000.00
Remaining			3,125.50

Total this Phase \$140.00

Phase 04. Reimbursable Expenses

Expenses

Mileage				785.24
Total Expenses		1.0 times	785.24	785.24

Total this Phase \$785.24

Phase 05. Plat Coordination

Billing Limits

	Current	Prior	To-Date
Total Billings	0.00	750.00	750.00
Limit			15,000.00
Remaining			14,250.00

Total this Phase 0.00

Total This Invoice \$12,522.99

Outstanding Invoices

Number	Date	Balance
215977	10/3/2024	9,836.40
Total		9,836.40

Total Now Due \$22,359.39

REQUISITION NO. 81A
(2023 Acquisition and Construction Account)

SIX MILE CREEK COMMUNITY DEVELOPMENT DISTRICT
(ST. JOHNS COUNTY, FLORIDA)

\$10,515,000
Capital Improvement Revenue Bonds
Series 2023 (2023 Project Area)

The undersigned, an Authorized Officer of Six Mile Creek Community Development District (the "District") hereby submits the following requisition for disbursement under and pursuant to the terms of the Master Trust Indenture from the District to U.S. Bank Trust Company, National Association, as successor trustee (the "Trustee"), dated as of July 1, 2007 (the "Master Indenture"), as amended and supplemented by the Eleventh Supplemental Trust Indenture between the District and Trustee, dated as of June 1, 2023 (the Master Indenture as amended and supplemented is hereinafter referred to as the "Indenture") (all capitalized terms used herein shall have the meaning ascribed to such term in the Indenture):

- (A) Requisition Number: **81A**
- (B) Name of Payee: **ETM**
First Citizens
ABA Routing #
Jacksonville, FL
Account # - England, Thims & Miller, Inc
- (C) Amount Payable: **\$ 9,684.65**
- (D) Purpose for which paid or incurred (refer also to specific contract if amount is due and payable pursuant to a contract involving progress payments, or, state Costs of Issuance, if applicable):
Trailmark Phase 12 - CEI (WA#70) Invoice 216486 (October 2024)
- (E) Fund or Account and subaccount, if any, from which disbursement is to be made:
 - \$ _____ Assessment Area 2 – Phase 3C Subaccount
 - \$ 9,684.65 Assessment Area 3 – Phase 3 Subaccount

The undersigned hereby certifies that obligations in the stated amount set forth above have been incurred by the District, that each disbursement set forth above is a proper charge against the 2023 Acquisition and Construction Account and the subaccount, if any, referenced above, that each disbursement set forth above was incurred in connection with the acquisition and construction of the 2023 Project and each represents a Cost of the 2023 Project, and has not previously been paid.

The undersigned hereby further certifies that there has not been filed with or served upon the District notice of any lien, right to lien, or attachment upon, or claim affecting the right to receive payment of, any of the moneys payable to the Payee set forth above, which has not been released or will not be released simultaneously with the payment hereof.

The undersigned hereby further certifies that such requisition contains no item representing payment on account of any retained percentage which the District is at the date of such certificate entitled to retain.

If this requisition is for a disbursement from other than the Costs of Issuance Account or for payment of capitalized interest, there shall be attached a resolution of the Governing Body of the District approving this requisition or approving the specific contract with respect to which disbursements pursuant to this requirement are due and payable.

Attached hereto are originals of the invoice(s) from the vendor of the property acquired or the services rendered with respect to which disbursement is hereby requested.

**SIX MILE CREEK COMMUNITY
DEVELOPMENT DISTRICT**

By: _____
Gregg F. Kern
Chairperson, Board of Supervisors

**CONSULTING ENGINEER'S APPROVAL FOR NON-COST OF ISSUANCE AND
CAPITALIZED INTEREST REQUESTS ONLY**

If this requisition is for a disbursement from other than Capitalized Interest or Costs of Issuance, the undersigned Consulting Engineer hereby certifies that this disbursement is for a Cost of the 2023 Project and is consistent with: (i) the applicable acquisition or construction contract; (ii) the plans and specifications for the portion of the 2023 Project with respect to which such disbursement is being made; and, (iii) the report of the Consulting Engineer attached as an Exhibit to the Eleventh Supplemental Trust Indenture, as such report shall have been amended or modified on the date hereof.

By:  _____
Consulting Engineer



Six Mile Creek Community Development District
6200 Lee Vista Boulevard Ste 300
Orlando, FL 32822

October 31, 2024

Invoice No: 216486

Total This Invoice \$9,684.65

Project 22471.00000 TrailMark Phase 12 - CEI (WA#70)

Email to Teresa Viscarra

Professional Services rendered through October 26, 2024

Phase 01 CEI Services

Labor

			Hours	Rate	Amount	
Principal - Vice President						
Wild, Scott	10/5/2024		1.00	320.00	320.00	
Wild, Scott	10/26/2024		1.00	320.00	320.00	
CEI Project Manager						
Donchez, James	10/5/2024		.50	175.00	87.50	
Donchez, James	10/12/2024		.50	175.00	87.50	
Donchez, James	10/19/2024		.50	175.00	87.50	
Donchez, James	10/26/2024		.50	175.00	87.50	
CEI Inspector						
Lanh, Pong	10/5/2024		13.00	125.00	1,625.00	
Lanh, Pong	10/12/2024		8.50	125.00	1,062.50	
Lanh, Pong	10/19/2024		6.50	125.00	812.50	
Lanh, Pong	10/26/2024		6.50	125.00	812.50	
Totals			38.50		5,302.50	
Total Labor						5,302.50

Billing Limits	Current	Prior	To-Date
Total Billings	5,302.50	101,568.25	106,870.75
Limit			110,000.00
Remaining			3,129.25

Total this Phase \$5,302.50

Phase 02 Progress Meetings

Labor

			Hours	Rate	Amount
Principal - Vice President					
Wild, Scott	10/26/2024		1.00	320.00	320.00
Engineer					
Hebb, Cara	10/5/2024		.50	165.00	82.50
Hebb, Cara	10/12/2024		.50	165.00	82.50
Hebb, Cara	10/19/2024		.25	165.00	41.25

Project	22471.00000	TrailMark Phase 12 - CEI (WA#70)	Invoice	216486
---------	-------------	----------------------------------	---------	--------

Hebb, Cara	10/26/2024	.25	165.00	41.25
Totals		2.50		567.50
Total Labor				567.50

Billing Limits	Current	Prior	To-Date	
Total Billings	567.50	35,495.75	36,063.25	
Limit			37,080.00	
Remaining			1,016.75	
		Total this Phase		\$567.50

Phase 03 CDD Tax Exempt Purchase Requisitions

Labor		Hours	Rate	Amount
Principal - Vice President				
Wild, Scott	10/5/2024	1.00	320.00	320.00
Wild, Scott	10/26/2024	1.00	320.00	320.00
Engineer				
Hebb, Cara	10/5/2024	2.00	165.00	330.00
Hebb, Cara	10/12/2024	4.50	165.00	742.50
Hebb, Cara	10/26/2024	5.50	165.00	907.50
CEI Sr. Inspector				
Ellins, Jason	10/5/2024	1.00	155.00	155.00
Ellins, Jason	10/19/2024	1.00	155.00	155.00
Ellins, Jason	10/26/2024	1.00	155.00	155.00
Totals		17.00		3,085.00
Total Labor				3,085.00

Billing Limits	Current	Prior	To-Date	
Total Billings	3,085.00	11,676.00	14,761.00	
Limit			15,000.00	
Remaining			239.00	
		Total this Phase		\$3,085.00

Phase 04 Owner Requested Plan Revisions

Billing Limits	Current	Prior	To-Date	
Total Billings	0.00	20,000.00	20,000.00	
Limit			20,000.00	
		Total this Phase		0.00

Phase 05 Reimbursable Expenses

Expenses				
Mileage			432.15	
Total Expenses		1.0 times	432.15	432.15

Billing Limits	Current	Prior	To-Date	
Total Billings	432.15	11,195.86	11,628.01	
Limit			15,000.00	
Remaining			3,371.99	

Total this Phase \$432.15

Phase 06 Plat Coordination

Labor

		Hours	Rate	Amount
Project Manager				
Harris, Thomas	10/5/2024	.50	190.00	95.00
Assoc. Project Manager				
Miller, Emily	10/5/2024	2.25	90.00	202.50
Totals		2.75		297.50
Total Labor				297.50

Billing Limits

	Current	Prior	To-Date
Total Billings	297.50	6,189.97	6,487.47
Limit			15,000.00
Remaining			8,512.53

Total this Phase \$297.50

Total This Invoice \$9,684.65

Outstanding Invoices

Number	Date	Balance
215989	10/3/2024	18,575.72
Total		18,575.72

Total Now Due \$28,260.37

**REQUISITION NO. 173
SIX MILE CREEK COMMUNITY DEVELOPMENT DISTRICT
(ST. JOHNS COUNTY, FLORIDA)**

**\$8,250,000
CAPITAL IMPROVEMENT AND
REFUNDING REVENUE BOND SERIES
2021 (Assessment Area 2, Phase 3B)**

A/C 226000005

The undersigned, a Responsible Officer of Six Mile Creek Community Development District (the "District") hereby submits the following requisition for disbursement under and pursuant to the terms of the Master Trust Indenture from the District to U. S. Bank National Association, as trustee (the "Trustee"), dated as of July 1, 2007, as supplemented by a Ninth Supplemental Trust Indenture, dated as of November 1, 2021 (collectively, the "Indenture"; all capitalized terms used herein shall have the meaning ascribed to such term in the Indenture):

(A) Requisition Number: 173

(B) Name of Payee: ETM
First Citizens
ABA Routing #
Jacksonville, FL
Account # - England, Thims & Miller, Inc.

(C) Amount Payable: Total: \$ 801.00

(D) Purpose for which paid or incurred (refer also to specific contract if amount is due and payable pursuant to a contract involving progress payments, or, state Costs of Issuance, if applicable: Master Site Planning (WA#51) Invoice 217027 (November 2024)

(E) Fund or Account from which disbursement to be made:

Capital Improvement and Refunding Revenue Bond Series 2021 (Assessment Area 2, Phase 3B)

The undersigned hereby certifies that:

1. obligations in the stated amount set forth above have been incurred by the District,
2. each disbursement set forth above is a proper charge against the Phase 1 Acquisition and Construction Account;
3. each disbursement set forth above was incurred in connection with the acquisition and/or construction of the Project;

4. each disbursement represents a Cost of the Project which has not previously been paid.

The undersigned hereby further certifies that there has not been filed with or served upon the District notice of any lien, right to lien, or attachment upon, or claim affecting the right to receive payment of, any of the moneys payable to the Payee set forth above, which has not been released or will not be released simultaneously with the payment hereof.

The undersigned hereby further certifies that such requisition contains no item representing payment on account of any retained percentage which the District is at the date of such certificate entitled to retain.

Attached hereto are originals of the invoice(s) from the vendor of the property acquired or the services rendered with respect to which disbursement is hereby requested.

**SIX MILE CREEK COMMUNITY
DEVELOPMENT DISTRICT**

By: _____
Chairperson, Board of Supervisors

CONSULTING ENGINEER'S APPROVAL

The undersigned Consulting Engineer hereby certifies that this disbursement is for a Cost of the Project and is consistent with: (i) the applicable acquisition or construction contract; (ii) the plans and specifications for the portion of the Project with respect to which such disbursement is being made; and (iii) the report of the Consulting Engineer, as such report shall have been amended or modified on the date hereof.

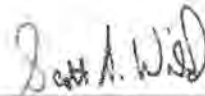

Consulting Engineer



Six Mile Creek Community Development District
6200 Lee Vista Boulevard Ste 300
Orlando, FL 32822

November 27, 2024
Invoice No: 217027

Total This Invoice \$801.00

Project 20291.00000 Master Site Planning (WA#51)

Professional Services rendered through November 23, 2024

Phase 01 Master Site Planning

Labor

			Hours	Rate	Amount
Engineering/Landscape Designer					
Simonelli, Dino	11/2/2024		1.00	131.00	131.00
Totals			1.00		131.00
Total Labor					131.00

Billing Limits

	Current	Prior	To-Date
Total Billings	131.00	27,338.50	27,469.50
Limit			35,000.00
Remaining			7,530.50
Total this Phase			\$131.00

Phase 02. Master Planning Coordination Meetings

Labor

			Hours	Rate	Amount
Executive VP/Chief Engineer					
Wild, Scott	11/2/2024		1.00	335.00	335.00
Wild, Scott	11/16/2024		1.00	335.00	335.00
Totals			2.00		670.00
Total Labor					670.00

Billing Limits

	Current	Prior	To-Date
Total Billings	670.00	33,432.50	34,102.50
Limit			50,000.00
Remaining			15,897.50
Total this Phase			\$670.00

Phase XP Expenses

Total this Phase 0.00

Total This Invoice \$801.00

Outstanding Invoices

Number	Date	Balance
216447	10/30/2024	670.00
Total		670.00

Total Now Due **\$1,471.00**

REQUISITION NO. 13
(2024 Acquisition and Construction Account)

SIX MILE CREEK COMMUNITY DEVELOPMENT DISTRICT
(ST. JOHNS COUNTY, FLORIDA)

\$5,790,000
Capital Improvement Revenue Bonds
Series 2024 (2024 Project Area)

The undersigned, an Authorized Officer of Six Mile Creek Community Development District (the "District") hereby submits the following requisition for disbursement under and pursuant to the terms of the Master Trust Indenture from the District to U.S. Bank Trust Company, National Association, as successor trustee (the "Trustee"), dated as of July 1, 2007 (the "Master Indenture"), as amended and supplemented by the Twelfth Supplemental Trust Indenture between the District and Trustee, dated as of October 1, 2024 (the Master Indenture as amended and supplemented is hereinafter referred to as the "Indenture") (all capitalized terms used herein shall have the meaning ascribed to such term in the Indenture):

- (A) Requisition Number: **13**
- (B) Name of Payee: **ETM**
First Citizens
ABA Routing #
Jacksonville, FL
Account # - England, Thims & Miller, Inc
- (C) Amount Payable: **\$ 10,419.50**
- (D) Purpose for which paid or incurred (refer also to specific contract if amount is due and payable pursuant to a contract involving progress payments, or, state Costs of Issuance, if applicable):
Phase 13 CEI – Invoice 217039 (November 2024)
- (E) Fund or Account and subaccount, if any, from which disbursement is to be made:
2024 Acquisition and Construction Account

The undersigned hereby certifies that obligations in the stated amount set forth above have been incurred by the District, that each disbursement set forth above is a proper charge against the 2024 Acquisition and Construction Account and the subaccount, if any, referenced above, that each disbursement set forth above was incurred in connection with the acquisition and construction of the 2024 Project and each represents a Cost of the 2024 Project, and has not previously been paid.

The undersigned hereby further certifies that there has not been filed with or served upon the District notice of any lien, right to lien, or attachment upon, or claim affecting the right to receive payment of, any of the moneys payable to the Payee set forth above, which has not been released or will not be released simultaneously with the payment hereof.

The undersigned hereby further certifies that such requisition contains no item representing payment on account of any retained percentage which the District is at the date of such certificate entitled to retain.

If this requisition is for a disbursement from other than the Costs of Issuance Account or for payment of capitalized interest, there shall be attached a resolution of the Governing Body of the District approving this requisition or approving the specific contract with respect to which disbursements pursuant to this requirement are due and payable.

Attached hereto or on file with the District are originals of the invoice(s) from the vendor of the property acquired or the services rendered with respect to which disbursement is hereby requested.

**SIX MILE CREEK COMMUNITY
DEVELOPMENT DISTRICT**

By: _____
Chairperson, Board of Supervisors

**CONSULTING ENGINEER'S APPROVAL FOR NON-COST OF ISSUANCE AND
CAPITALIZED INTEREST REQUESTS ONLY**

If this requisition is for a disbursement from other than Capitalized Interest or Costs of Issuance, the undersigned Consulting Engineer hereby certifies that this disbursement is for a Cost of the 2024 Project and is consistent with: (i) the applicable acquisition or construction contract; (ii) the plans and specifications for the portion of the 2024 Project with respect to which such disbursement is being made; and, (iii) the report of the Consulting Engineer attached as an Exhibit to the Eleventh Supplemental Trust Indenture, as such report shall have been amended or modified on the date hereof.

By: Scott A. Wied
Consulting Engineer



Teresa Viscarra
Six Mile Creek Community Development District
6200 Lee Vista Boulevard Ste 300
Orlando, FL 32822

November 27, 2024
Invoice No: 217039

Total This Invoice \$10,419.50

Project 21363.01000 Six Mile Creek CDD - Phase 13 CEI (WA#80)

Professional Services rendered through November 23, 2024

Phase 01. CEI Services

Labor

			Hours	Rate	Amount
Executive Vice President					
Wild, Scott	11/2/2024		1.00	362.00	362.00
Wild, Scott	11/9/2024		1.00	362.00	362.00
Wild, Scott	11/16/2024		1.50	362.00	543.00
Senior Engineer/Senior Project Manager					
Wild, Scott	11/23/2024		1.00	244.00	244.00
CEI Project Manager/Project Admin.					
Donchez, James	11/2/2024		1.50	219.00	328.50
Donchez, James	11/9/2024		1.00	219.00	219.00
Donchez, James	11/16/2024		1.00	219.00	219.00
Donchez, James	11/23/2024		1.00	219.00	219.00
CEI Inspector					
Lanh, Pong	11/2/2024		7.50	140.00	1,050.00
Lanh, Pong	11/9/2024		9.50	140.00	1,330.00
Lanh, Pong	11/16/2024		3.50	140.00	490.00
Lanh, Pong	11/23/2024		3.50	140.00	490.00
Totals			33.00		5,856.50
Total Labor					5,856.50

Billing Limits

	Current	Prior	To-Date
Labor	5,856.50	55,048.25	60,904.75
Limit			108,576.00
Remaining			47,671.25
Total this Phase			\$5,856.50

Phase 02. Progress Meetings

Labor

			Hours	Rate	Amount
Executive Vice President					
Wild, Scott	11/9/2024		1.00	362.00	362.00
Senior Engineer/Senior Project Manager					
Wild, Scott	11/23/2024		1.00	244.00	244.00

Engineer

Hebb, Cara	11/2/2024	.50	186.00	93.00
Hebb, Cara	11/9/2024	.50	186.00	93.00
Hebb, Cara	11/16/2024	.50	186.00	93.00
Hebb, Cara	11/23/2024	.50	186.00	93.00

Totals		4.00		978.00
--------	--	------	--	--------

Total Labor 978.00

Billing Limits

		Current	Prior	To-Date
Labor		978.00	4,155.00	5,133.00
Limit				39,060.00
Remaining				33,927.00

Total this Phase \$978.00

Phase 03. CDD Tax Exempt Purchase Requisitions

Labor

		Hours	Rate	Amount
Executive Vice President				
Wild, Scott	11/2/2024	1.00	362.00	362.00
Wild, Scott	11/16/2024	1.00	362.00	362.00
Senior Engineer/Senior Project Manager				
Wild, Scott	11/23/2024	2.00	244.00	488.00
Totals		4.00		1,212.00

Total Labor 1,212.00

Billing Limits

		Current	Prior	To-Date
Labor		1,212.00	7,240.00	8,452.00
Limit				15,000.00
Remaining				6,548.00

Total this Phase \$1,212.00

Phase 04. Owner Requested Plan Revisions

Labor

		Hours	Rate	Amount
Engineer				
Hebb, Cara	11/9/2024	1.50	186.00	279.00
Engineering/Landscape Designer				
Jeter, Matthew	11/2/2024	1.00	152.00	152.00
Jeter, Matthew	11/9/2024	8.00	152.00	1,216.00
Jeter, Matthew	11/16/2024	3.00	152.00	456.00
Totals		13.50		2,103.00

Total Labor 2,103.00

Billing Limits

		Current	Prior	To-Date
Labor		2,103.00	2,592.50	4,695.50
Limit				20,000.00
Remaining				15,304.50

Total this Phase \$2,103.00

Phase 05. Plat Coordination

Labor

		Hours	Rate	Amount
Project Manager				
Harris, Thomas	11/9/2024	1.25	216.00	270.00
Totals		1.25		270.00
Total Labor				270.00
Billing Limits		Current	Prior	To-Date
Total Billings		270.00	0.00	270.00
Limit				10,000.00
Remaining				9,730.00
			Total this Phase	\$270.00

Phase XP. Reimbursable Expenses

	Total this Phase	0.00
		Total This Invoice
		<u><u>\$10,419.50</u></u>

Outstanding Invoices

	Number	Date	Balance	
	216452	10/30/2024	9,268.47	
	Total		9,268.47	
				Total Now Due
				\$19,687.97

REQUISITION NO. 95
(2023 Acquisition and Construction Account)

SIX MILE CREEK COMMUNITY DEVELOPMENT DISTRICT
(ST. JOHNS COUNTY, FLORIDA)

\$10,515,000
Capital Improvement Revenue Bonds
Series 2023 (2023 Project Area)

The undersigned, an Authorized Officer of Six Mile Creek Community Development District (the "District") hereby submits the following requisition for disbursement under and pursuant to the terms of the Master Trust Indenture from the District to U.S. Bank Trust Company, National Association, as successor trustee (the "Trustee"), dated as of July 1, 2007 (the "Master Indenture"), as amended and supplemented by the Eleventh Supplemental Trust Indenture between the District and Trustee, dated as of June 1, 2023 (the Master Indenture as amended and supplemented is hereinafter referred to as the "Indenture") (all capitalized terms used herein shall have the meaning ascribed to such term in the Indenture):

- (A) Requisition Number: **95**
- (B) Name of Payee: **ETM**
First Citizens
ABA Routing #
Jacksonville, FL
Account # - England, Thims & Miller, Inc
- (C) Amount Payable: **\$4,259.25**
- (D) Purpose for which paid or incurred (refer also to specific contract if amount is due and payable pursuant to a contract involving progress payments, or, state Costs of Issuance, if applicable):

Trailmark East Parcel - Phase 3 CEI (WA#73) Invoice 217042 (November 2024)

- (E) Fund or Account and subaccount, if any, from which disbursement is to be made:

\$ 4.259.25 Assessment Area 2 – Phase 3C Subaccount

\$ _____ Assessment Area 3 – Phase 3 Subaccount

The undersigned hereby certifies that obligations in the stated amount set forth above have been incurred by the District, that each disbursement set forth above is a proper charge against the 2023 Acquisition and Construction Account and the subaccount, if any, referenced above, that each disbursement set forth above was incurred in connection with the acquisition and construction of the 2023 Project and each represents a Cost of the 2023 Project, and has not previously been paid.

The undersigned hereby further certifies that there has not been filed with or served upon the District notice of any lien, right to lien, or attachment upon, or claim affecting the right to receive payment of, any of the moneys payable to the Payee set forth above, which has not been released or will not be released simultaneously with the payment hereof.

The undersigned hereby further certifies that such requisition contains no item representing payment on account of any retained percentage which the District is at the date of such certificate entitled to retain.

If this requisition is for a disbursement from other than the Costs of Issuance Account or for payment of capitalized interest, there shall be attached a resolution of the Governing Body of the District approving this requisition or approving the specific contract with respect to which disbursements pursuant to this requirement are due and payable.

Attached hereto are originals of the invoice(s) from the vendor of the property acquired or the services rendered with respect to which disbursement is hereby requested.

**SIX MILE CREEK COMMUNITY
DEVELOPMENT DISTRICT**

By: _____
Chairperson, Board of Supervisors

**CONSULTING ENGINEER'S APPROVAL FOR NON-COST OF ISSUANCE AND
CAPITALIZED INTEREST REQUESTS ONLY**

If this requisition is for a disbursement from other than Capitalized Interest or Costs of Issuance, the undersigned Consulting Engineer hereby certifies that this disbursement is for a Cost of the 2023 Project and is consistent with: (i) the applicable acquisition or construction contract; (ii) the plans and specifications for the portion of the 2023 Project with respect to which such disbursement is being made; and, (iii) the report of the Consulting Engineer attached as an Exhibit to the Eleventh Supplemental Trust Indenture, as such report shall have been amended or modified on the date hereof.

By: Scott A. Wild
Consulting Engineer

Six Mile Creek Community Development District
 6200 Lee Vista Boulevard Ste 300
 Orlando, FL 32822

November 27, 2024

Invoice No: 217042

Total This Invoice \$4,259.25

Project 21407.01000 TrailMark East Parcel - Phase 3 CEI (WA #73)

Email to Teresa

Professional Services rendered through November 23, 2024

Phase 01. CEI Services

Labor

			Hours	Rate	Amount
Executive VP/Chief Engineer					
Wild, Scott	11/2/2024		1.00	335.00	335.00
Wild, Scott	11/9/2024		1.00	335.00	335.00
Wild, Scott	11/16/2024		1.00	335.00	335.00
Wild, Scott	11/23/2024		1.00	335.00	335.00
CEI Inspector					
Lanh, Pong	11/2/2024		18.00	132.00	2,376.00
Lanh, Pong	11/9/2024		16.50	132.00	2,178.00
Lanh, Pong	11/16/2024		4.50	132.00	594.00
Lanh, Pong	11/23/2024		5.00	132.00	660.00
Administrative Support					
Risner, Ella	11/9/2024		2.00	95.00	190.00
	Totals		50.00		7,338.00
	Total Labor				7,338.00

Billing Limits	Current	Prior	To-Date
Total Billings	7,338.00	99,678.50	107,016.50
Limit			110,000.00
Remaining			2,983.50

Total this Phase \$7,338.00

Phase 02. Progress Meetings

Labor

			Hours	Rate	Amount
Executive VP/Chief Engineer					
Wild, Scott	11/9/2024		1.00	335.00	335.00
Engineer					
Hebb, Cara	11/2/2024		1.25	175.00	218.75
Hebb, Cara	11/9/2024		.50	175.00	87.50
Hebb, Cara	11/16/2024		.50	175.00	87.50
Hebb, Cara	11/23/2024		.50	175.00	87.50
	Totals		3.75		816.25
	Total Labor				816.25

Billing Limits		Current	Prior	To-Date
Total Billings		816.25	23,086.25	23,902.50
Limit				50,512.00
Remaining				26,609.50
Total this Phase				\$816.25

Phase	03.	Owner Requested Plan Revisions		
Billing Limits		Current	Prior	To-Date
Total Billings		0.00	6,874.50	6,874.50
Limit				10,000.00
Remaining				3,125.50
Total this Phase				0.00

Phase	04.	Reimbursable Expenses		
Total this Phase				0.00

Phase	05.	Plat Coordination		
Labor			Hours	Rate
Executive VP/Chief Engineer				Amount
Wild, Scott	11/23/2024		1.00	335.00
Totals			1.00	335.00
Total Labor				335.00

Billing Limits		Current	Prior	To-Date
Labor		335.00	750.00	1,085.00
Limit				15,000.00
Remaining				13,915.00
Additional Fees			Total this Phase	335.00
Credit for Change Order		Total Additional Fees		-4,230.00
Total This Invoice				<u>\$4,259.25</u>

Outstanding Invoices			
	Number	Date	Balance
	216453	10/30/2024	12,522.99
	Total		12,522.99
Total Now Due			\$16,782.24

REQUISITION NO. 83A
(2023 Acquisition and Construction Account)

SIX MILE CREEK COMMUNITY DEVELOPMENT DISTRICT
(ST. JOHNS COUNTY, FLORIDA)

\$10,515,000
Capital Improvement Revenue Bonds
Series 2023 (2023 Project Area)

The undersigned, an Authorized Officer of Six Mile Creek Community Development District (the "District") hereby submits the following requisition for disbursement under and pursuant to the terms of the Master Trust Indenture from the District to U.S. Bank Trust Company, National Association, as successor trustee (the "Trustee"), dated as of July 1, 2007 (the "Master Indenture"), as amended and supplemented by the Eleventh Supplemental Trust Indenture between the District and Trustee, dated as of June 1, 2023 (the Master Indenture as amended and supplemented is hereinafter referred to as the "Indenture") (all capitalized terms used herein shall have the meaning ascribed to such term in the Indenture):

- (A) Requisition Number: **83A**
- (B) Name of Payee: **ETM**
First Citizens
ABA Routing #
Jacksonville, FL
Account # - England, Thims & Miller, Inc
- (C) Amount Payable: **\$ 21,671.50**
- (D) Purpose for which paid or incurred (refer also to specific contract if amount is due and payable pursuant to a contract involving progress payments, or, state Costs of Issuance, if applicable):

Trailmark Phase 12 - CEI (WA#70) Invoice 217112 (November 2024)	\$13,611.50
Trailmark Drive at Pacetti Road-Traffic Signal Design Services (WA#79) Invoice 217408 (November 2024)	<u>\$8,060.00</u>
TOTAL REQUISITION 83A	\$21,671.50

(E) Fund or Account and subaccount, if any, from which disbursement is to be made:

- \$ _____ Assessment Area 2 – Phase 3C Subaccount
- \$ 13,611.50 Assessment Area 3 – Phase 3 Subaccount
- \$ 8,060.00 Assessment Area 3 – Phase 3 Subaccount

The undersigned hereby certifies that obligations in the stated amount set forth above have been incurred by the District, that each disbursement set forth above is a proper charge against the 2023 Acquisition and Construction Account and the subaccount, if any, referenced above, that each disbursement set forth above was incurred in connection with the acquisition and construction of the 2023 Project and each represents a Cost of the 2023 Project, and has not previously been paid.

The undersigned hereby further certifies that there has not been filed with or served upon the District notice of any lien, right to lien, or attachment upon, or claim affecting the right to receive payment of, any of the moneys payable to the Payee set forth above, which has not been released or will not be released simultaneously with the payment hereof.

The undersigned hereby further certifies that such requisition contains no item representing payment on account of any retained percentage which the District is at the date of such certificate entitled to retain.

If this requisition is for a disbursement from other than the Costs of Issuance Account or for payment of capitalized interest, there shall be attached a resolution of the Governing Body of the District approving this requisition or approving the specific contract with respect to which disbursements pursuant to this requirement are due and payable.

Attached hereto are originals of the invoice(s) from the vendor of the property acquired or the services rendered with respect to which disbursement is hereby requested.

**SIX MILE CREEK COMMUNITY
DEVELOPMENT DISTRICT**

By: _____
Chairperson, Board of Supervisors

**CONSULTING ENGINEER'S APPROVAL FOR NON-COST OF ISSUANCE AND
CAPITALIZED INTEREST REQUESTS ONLY**

If this requisition is for a disbursement from other than Capitalized Interest or Costs of Issuance, the undersigned Consulting Engineer hereby certifies that this disbursement is for a Cost of the 2023 Project and is consistent with: (i) the applicable acquisition or construction contract; (ii) the plans and specifications for the portion of the 2023 Project with respect to which such disbursement is being made; and, (iii) the report of the Consulting Engineer attached as an Exhibit to the Eleventh Supplemental Trust Indenture, as such report shall have been amended or modified on the date hereof.

By: _____
Consulting Engineer



Six Mile Creek Community Development District
6200 Lee Vista Boulevard Ste 300
Orlando, FL 32822

November 27, 2024

Invoice No: 217112

Total This Invoice \$13,611.50

Project 22471.00000 TrailMark Phase 12 - CEI (WA#70)

Email to Teresa Viscarra

Professional Services rendered through November 23, 2024

Phase 01 CEI Services

Labor

			Hours	Rate	Amount
Principal - Vice President					
Wild, Scott	11/2/2024		5.50	320.00	1,760.00
Wild, Scott	11/9/2024		2.00	320.00	640.00
Wild, Scott	11/16/2024		1.50	320.00	480.00
Project Manager					
Brooks, Jeffrey	11/16/2024		3.00	190.00	570.00
CEI Project Manager					
Donchez, James	11/2/2024		1.00	175.00	175.00
Donchez, James	11/9/2024		.75	175.00	131.25
Donchez, James	11/16/2024		.75	175.00	131.25
Donchez, James	11/23/2024		1.00	175.00	175.00
CEI Inspector					
Lanh, Pong	11/2/2024		5.50	125.00	687.50
Lanh, Pong	11/9/2024		5.00	125.00	625.00
Lanh, Pong	11/16/2024		2.50	125.00	312.50
Totals			28.50		5,687.50
Total Labor					5,687.50

Billing Limits	Current	Prior	To-Date
Total Billings	5,687.50	106,870.75	112,558.25
Limit			115,000.00
Remaining			2,441.75

Total this Phase \$5,687.50

Phase 02 Progress Meetings

Labor

			Hours	Rate	Amount
Principal - Vice President					
Wild, Scott	11/23/2024		1.00	205.00	205.00
Engineer					
Hebb, Cara	11/2/2024		.25	165.00	41.25
Hebb, Cara	11/9/2024		2.50	165.00	412.50
Hebb, Cara	11/16/2024		.50	165.00	82.50

Project	22471.00000	TrailMark Phase 12 - CEI (WA#70)	Invoice	217112
---------	-------------	----------------------------------	---------	--------

Hebb, Cara	11/23/2024	.50	165.00	82.50	
Totals		4.75		823.75	
Total Labor					823.75

Billing Limits	Current	Prior	To-Date	
Total Billings	823.75	36,063.25	36,887.00	
Limit			37,080.00	
Remaining			193.00	
		Total this Phase		\$823.75

Phase	03	CDD Tax Exempt Purchase Requisitions			
Labor					

		Hours	Rate	Amount	
Principal - Vice President					
Wild, Scott	11/2/2024	1.00	320.00	320.00	
Wild, Scott	11/16/2024	1.00	320.00	320.00	
Wild, Scott	11/23/2024	1.00	205.00	205.00	
Project Manager					
Ellins, Jason	11/16/2024	1.00	190.00	190.00	
Totals		4.00		1,035.00	
Total Labor					1,035.00

Billing Limits	Current	Prior	To-Date	
Total Billings	1,035.00	14,761.00	15,796.00	
Limit			20,000.00	
Remaining			4,204.00	
		Total this Phase		\$1,035.00

Phase	04	Owner Requested Plan Revisions			
Labor					

		Hours	Rate	Amount	
Engineer					
Hebb, Cara	11/2/2024	8.25	165.00	1,361.25	
Hebb, Cara	11/9/2024	.50	165.00	82.50	
Hebb, Cara	11/16/2024	2.50	165.00	412.50	
Hebb, Cara	11/23/2024	4.00	165.00	660.00	
Engineering/Landscape Designer					
Jeter, Matthew	11/2/2024	12.00	140.00	1,680.00	
Jeter, Matthew	11/9/2024	1.00	140.00	140.00	
Jeter, Matthew	11/16/2024	2.00	140.00	280.00	
Totals		30.25		4,616.25	
Total Labor					4,616.25

Billing Limits	Current	Prior	To-Date	
Total Billings	4,616.25	20,000.00	24,616.25	
Limit			25,000.00	
Remaining			383.75	
		Total this Phase		\$4,616.25

Phase 05 Reimbursable Expenses

Expenses

Permits				104.00	
Total Expenses			1.0 times	104.00	104.00

Billing Limits

	Current	Prior	To-Date
Total Billings	104.00	11,628.01	11,732.01
Limit			15,000.00
Remaining			3,267.99

Total this Phase \$104.00

Phase 06 Plat Coordination

Labor

		Hours	Rate	Amount
Project Manager				
Harris, Thomas	11/2/2024	.50	190.00	95.00
Harris, Thomas	11/9/2024	.25	190.00	47.50
Harris, Thomas	11/16/2024	.25	190.00	47.50
Assoc. Project Manager				
Miller, Emily	11/9/2024	1.00	90.00	90.00
Miller, Emily	11/16/2024	5.50	90.00	495.00
Miller, Emily	11/23/2024	2.50	90.00	225.00
PROJECT SURVEYOR/MANAGER				
Miller, Emily	11/2/2024	1.50	90.00	135.00
Totals		11.50		1,135.00

Total Labor 1,135.00

Expenses

Permits				210.00	
Total Expenses			1.0 times	210.00	210.00

Billing Limits

	Current	Prior	To-Date
Total Billings	1,345.00	6,487.47	7,832.47
Limit			15,000.00
Remaining			7,167.53

Total this Phase \$1,345.00

Total This Invoice \$13,611.50

Outstanding Invoices

Number	Date	Balance
216486	10/31/2024	9,684.65
Total		9,684.65

Total Now Due \$23,296.15

**St. Johns County BCC
Central Cashiering
Cashier # 24-065184**

Name : Whisper Creek Phase 12 Unit C

Trans Date: 10/29/2024 3:28:13 PM

Charges:

Description	Assoc	Assoc Key	Charge Amount
SECOND RE-SUBMISSION Whisper Creek Phase 12 Unit C	AP	PLAT-2024000019	\$104.00

Payment:

Description	Order Id	Charge Amount
NXLX	190577595	\$104.00

From: [Emily Miller](#)
To: [Marilyn Galen](#); [Angela Morales](#)
Subject: Re: St. Johns County ACH
Date: Friday, November 1, 2024 9:42:56 AM
Attachments: [image001.png](#)
[Receipt.PDF](#)
[Receipt.PDF](#)

Good morning,

Please see the attached receipts for:

Silver Falls (Silverleaf Parcel 22A) Phase 1A Replat (S0025259.00): \$104.00 paid with ETM Survey & Mapping account.

Whisper Creek Phase 12C (ETM # 22471.00): \$104.00 paid with the ETM account.

Emily Miller Project Manager

MillerE@etminc.com | office: 904.265.3141 | cell: 904.806.8845
England-Thims & Miller, Inc. | [Career Opportunities](#)

From: Marilyn Galen <GalenM@etminc.com>
Sent: Friday, November 1, 2024 9:34 AM
To: Emily Miller <MillerE@etminc.com>
Subject: St. Johns County ACH

Hi Emily,

Did you do an ACH to SJC for \$104.00 for ETM? If so, can you please send me the backup and job number?

Thank you,



Marilyn Galen Senior Accounting Specialist
GalenM@etminc.com | office: 904.265.3186
etminc.com | [Career Opportunities](#)

ETM & ETM Survey Check Request

REQUESTED BY: Emily S. Miller

DEPARTMENT: England-Thims & Miller, Inc.

APPROVED BY: _____

DATE: 11-21-2024

REQUEST	
Amount:	\$210.00
Project Number:	22.471
Reason for Request:	Recordation of Plat
<i>*If requesting for Events and Sponsorships - use the ETM Event and Sponsorship Request Form*</i>	

PAYMENT DETAILS	
Check Payable to:	St Johns County Clerk of Court
Address:	4010 Lewis Speedway
	St. Augustine, FL. 32084
Special Instructions:	

[FOR ACCOUNTING USE ONLY]	
GENERAL LEDGER NO.	AMOUNT DR (CR)
TOTAL	



Six Mile Creek Community Development District
6200 Lee Vista Boulevard Ste 300
Orlando, FL 32822

December 03, 2024
Invoice No: 217408

Total This Invoice \$8,060.00

Project 22471.03000 Trailmark Drive at Pacetti Road - Traffic Signal Design Services -WA#79
Professional Services rendered through November 23, 2024

Phase	Lump Sum	Fee	Percent Complete	Earned	Current Billing
1. Traffic Signal Design		41,200.00	80.00	32,960.00	4,120.00
2. Geotechnical Exploration & Testing					
A. ETM Coordintion		3,000.00	80.00	2,400.00	900.00
B. Subconsultant		6,000.00	0.00	0.00	0.00
3. Mast Arm, Upright & Foundation-Structural Design					
A. ETM Coordination		3,000.00	80.00	2,400.00	900.00
B. Subconsultant		6,000.00	0.00	0.00	0.00
4. Signing & Pavement Markings		3,600.00	80.00	2,880.00	360.00
5. Utility Coordination		8,200.00	80.00	6,560.00	820.00
6. Sub-Utility Exploration & Associated Survey Tasks					
A. ETM Coordination		3,000.00	90.00	2,700.00	0.00
B. Subconsultant		6,000.00	90.00	5,400.00	0.00
7. Permitting Activities & Coordination with SJC		9,600.00	80.00	7,680.00	960.00
8. Post-Design Services		10,400.00	0.00	0.00	0.00
Total Fee		100,000.00		62,980.00	8,060.00
Total Fee					8,060.00
Total this Phase					\$8,060.00

Phase	09	Topographical Survey Allowance	Total Fee	0.00
Total Fee		10,000.00		
Percent Complete		100.00		
Total Fee			0.00	

Total this Phase **0.00**

Total This Invoice **\$8,060.00**

REQUISITION NO. 99
(2023 Acquisition and Construction Account)

SIX MILE CREEK COMMUNITY DEVELOPMENT DISTRICT
(ST. JOHNS COUNTY, FLORIDA)

\$10,515,000
Capital Improvement Revenue Bonds
Series 2023 (2023 Project Area)

The undersigned, an Authorized Officer of Six Mile Creek Community Development District (the "District") hereby submits the following requisition for disbursement under and pursuant to the terms of the Master Trust Indenture from the District to U.S. Bank Trust Company, National Association, as successor trustee (the "Trustee"), dated as of July 1, 2007 (the "Master Indenture"), as amended and supplemented by the Eleventh Supplemental Trust Indenture between the District and Trustee, dated as of June 1, 2023 (the Master Indenture as amended and supplemented is hereinafter referred to as the "Indenture") (all capitalized terms used herein shall have the meaning ascribed to such term in the Indenture):

- (A) Requisition Number: **99**
- (B) Name of Payee: **ETM**
First Citizens
ABA Routing #
Jacksonville, FL
Account # - England, Thims & Miller, Inc
- (C) Amount Payable: **\$ 9,778.58**
- (D) Purpose for which paid or incurred (refer also to specific contract if amount is due and payable pursuant to a contract involving progress payments, or, state Costs of Issuance, if applicable):

Trailmark East Parcel - Phase 3 CEI (WA#73) Invoice 217495 (December 2024)

- (E) Fund or Account and subaccount, if any, from which disbursement is to be made:
 - \$ 9,778.58 Assessment Area 2 – Phase 3C Subaccount
 - \$ _____ Assessment Area 3 – Phase 3 Subaccount

The undersigned hereby certifies that obligations in the stated amount set forth above have been incurred by the District, that each disbursement set forth above is a proper charge against the 2023 Acquisition and Construction Account and the subaccount, if any, referenced above, that each disbursement set forth above was incurred in connection with the acquisition and construction of the 2023 Project and each represents a Cost of the 2023 Project, and has not previously been paid.

The undersigned hereby further certifies that there has not been filed with or served upon the District notice of any lien, right to lien, or attachment upon, or claim affecting the right to receive payment of, any of the moneys payable to the Payee set forth above, which has not been released or will not be released simultaneously with the payment hereof.

The undersigned hereby further certifies that such requisition contains no item representing payment on account of any retained percentage which the District is at the date of such certificate entitled to retain.

If this requisition is for a disbursement from other than the Costs of Issuance Account or for payment of capitalized interest, there shall be attached a resolution of the Governing Body of the District approving this requisition or approving the specific contract with respect to which disbursements pursuant to this requirement are due and payable.

Attached hereto are originals of the invoice(s) from the vendor of the property acquired or the services rendered with respect to which disbursement is hereby requested.

**SIX MILE CREEK COMMUNITY
DEVELOPMENT DISTRICT**

By: _____
Chairperson, Board of Supervisors

**CONSULTING ENGINEER'S APPROVAL FOR NON-COST OF ISSUANCE AND
CAPITALIZED INTEREST REQUESTS ONLY**

If this requisition is for a disbursement from other than Capitalized Interest or Costs of Issuance, the undersigned Consulting Engineer hereby certifies that this disbursement is for a Cost of the 2023 Project and is consistent with: (i) the applicable acquisition or construction contract; (ii) the plans and specifications for the portion of the 2023 Project with respect to which such disbursement is being made; and, (iii) the report of the Consulting Engineer attached as an Exhibit to the Eleventh Supplemental Trust Indenture, as such report shall have been amended or modified on the date hereof.

By: Scott A. Wild
Consulting Engineer

Six Mile Creek Community Development District
 6200 Lee Vista Boulevard Ste 300
 Orlando, FL 32822

January 03, 2025

Invoice No: 217495

Total This Invoice \$9,778.58

Project 21407.01000 TrailMark East Parcel - Phase 3 CEI (WA #73)
 Email to Teresa

Professional Services rendered through December 28, 2024

Phase 01. CEI Services

Labor

			Hours	Rate	Amount
Senior Engineer/Senior Project Manager					
Wild, Scott	12/7/2024		1.00	215.00	215.00
Wild, Scott	12/14/2024		1.00	215.00	215.00
Wild, Scott	12/21/2024		1.00	215.00	215.00
CEI Inspector					
Lanh, Pong	12/7/2024		12.00	132.00	1,584.00
Totals			15.00		2,229.00
Total Labor					2,229.00

Billing Limits

	Current	Prior	To-Date
Total Billings	2,229.00	107,016.50	109,245.50
Limit			110,000.00
Remaining			754.50
Total this Phase			\$2,229.00

Phase 02. Progress Meetings

Labor

			Hours	Rate	Amount
Engineer					
Hebb, Cara	11/30/2024		.50	175.00	87.50
Hebb, Cara	12/7/2024		.50	175.00	87.50
Hebb, Cara	12/14/2024		.25	175.00	43.75
Hebb, Cara	12/21/2024		.50	175.00	87.50
Totals			1.75		306.25
Total Labor					306.25

Billing Limits

	Current	Prior	To-Date
Total Billings	306.25	23,902.50	24,208.75
Limit			50,512.00
Remaining			26,303.25
Total this Phase			\$306.25

Phase 03. Owner Requested Plan Revisions

Labor

		Hours	Rate	Amount
Engineer				
Hebb, Cara	12/14/2024	.50	175.00	87.50
Hebb, Cara	12/21/2024	12.50	175.00	2,187.50
Hebb, Cara	12/28/2024	2.50	175.00	437.50
Totals		15.50		2,712.50
Total Labor				2,712.50

	Current	Prior	To-Date	
Billing Limits				
Total Billings	2,712.50	6,874.50	9,587.00	
Limit			10,000.00	
Remaining			413.00	
Total this Phase				\$2,712.50

Phase	04.	Reimbursable Expenses		
Expenses				
Mileage				568.83
Total Expenses				568.83
				1.0 times
Total this Phase				\$568.83

Phase	05.	Plat Coordination		
Labor				
		Hours	Rate	Amount
Project Manager				
Brooks, Jeffrey	12/14/2024	1.00	200.00	200.00
CEI Inspector				
Lanh, Pong	12/14/2024	12.00	132.00	1,584.00
Lanh, Pong	12/21/2024	13.50	132.00	1,782.00
Lanh, Pong	12/28/2024	3.00	132.00	396.00
Totals		29.50		3,962.00
Total Labor				3,962.00
Billing Limits				
Labor		3,962.00	1,085.00	5,047.00
Limit				15,000.00
Remaining				9,953.00
Total this Phase				\$3,962.00
Total This Invoice				<u>\$9,778.58</u>

Outstanding Invoices				
	Number	Date	Balance	
	216453	10/30/2024	12,522.99	
	217042	11/27/2024	4,259.25	
	Total		16,782.24	
Total Now Due				\$26,560.82

REQUISITION NO. 87A
(2023 Acquisition and Construction Account)

SIX MILE CREEK COMMUNITY DEVELOPMENT DISTRICT
(ST. JOHNS COUNTY, FLORIDA)

\$10,515,000
Capital Improvement Revenue Bonds
Series 2023 (2023 Project Area)

The undersigned, an Authorized Officer of Six Mile Creek Community Development District (the "District") hereby submits the following requisition for disbursement under and pursuant to the terms of the Master Trust Indenture from the District to U.S. Bank Trust Company, National Association, as successor trustee (the "Trustee"), dated as of July 1, 2007 (the "Master Indenture"), as amended and supplemented by the Eleventh Supplemental Trust Indenture between the District and Trustee, dated as of June 1, 2023 (the Master Indenture as amended and supplemented is hereinafter referred to as the "Indenture") (all capitalized terms used herein shall have the meaning ascribed to such term in the Indenture):

- (A) Requisition Number: **87A**
- (B) Name of Payee: **ETM**
First Citizens
ABA Routing #
Jacksonville, FL
Account # - England, Thims & Miller, Inc
- (C) Amount Payable: **\$ 9,141.90**
- (D) Purpose for which paid or incurred (refer also to specific contract if amount is due and payable pursuant to a contract involving progress payments, or, state Costs of Issuance, if applicable):

Trailmark Phase 12 - CEI (WA#70) Invoice 217515 (December 2024)	\$ 2,281.90
Trailmark Drive at Pacetti Road-Traffic Signal Design Services (WA#79) Invoice 217853 (December 2024)	<u>\$ 6,860.00</u>
TOTAL REQUISITION 87A	\$ 9,141.90

(E) Fund or Account and subaccount, if any, from which disbursement is to be made:

- \$ _____ Assessment Area 2 – Phase 3C Subaccount
- \$ 2,281.90 Assessment Area 3 – Phase 3 Subaccount
- \$ 6,860.00 Assessment Area 3 – Phase 3 Subaccount

The undersigned hereby certifies that obligations in the stated amount set forth above have been incurred by the District, that each disbursement set forth above is a proper charge against the 2023 Acquisition and Construction Account and the subaccount, if any, referenced above, that each disbursement set forth above was incurred in connection with the acquisition and construction of the 2023 Project and each represents a Cost of the 2023 Project, and has not previously been paid.

The undersigned hereby further certifies that there has not been filed with or served upon the District notice of any lien, right to lien, or attachment upon, or claim affecting the right to receive payment of, any of the moneys payable to the Payee set forth above, which has not been released or will not be released simultaneously with the payment hereof.

The undersigned hereby further certifies that such requisition contains no item representing payment on account of any retained percentage which the District is at the date of such certificate entitled to retain.

If this requisition is for a disbursement from other than the Costs of Issuance Account or for payment of capitalized interest, there shall be attached a resolution of the Governing Body of the District approving this requisition or approving the specific contract with respect to which disbursements pursuant to this requirement are due and payable.

Attached hereto are originals of the invoice(s) from the vendor of the property acquired or the services rendered with respect to which disbursement is hereby requested.

**SIX MILE CREEK COMMUNITY
DEVELOPMENT DISTRICT**

By: _____
Chairperson, Board of Supervisors

**CONSULTING ENGINEER'S APPROVAL FOR NON-COST OF ISSUANCE AND
CAPITALIZED INTEREST REQUESTS ONLY**

If this requisition is for a disbursement from other than Capitalized Interest or Costs of Issuance, the undersigned Consulting Engineer hereby certifies that this disbursement is for a Cost of the 2023 Project and is consistent with: (i) the applicable acquisition or construction contract; (ii) the plans and specifications for the portion of the 2023 Project with respect to which such disbursement is being made; and, (iii) the report of the Consulting Engineer attached as an Exhibit to the Eleventh Supplemental Trust Indenture, as such report shall have been amended or modified on the date hereof.

By: Scott A. Wild
Consulting Engineer



Six Mile Creek Community Development District
6200 Lee Vista Boulevard Ste 300
Orlando, FL 32822

January 06, 2025

Invoice No: 217515

Total This Invoice \$2,281.90

Project 22471.00000 TrailMark Phase 12 - CEI (WA#70)

Email to Teresa Viscarra

Professional Services rendered through December 28, 2024

Phase 01 CEI Services

Labor

			Hours	Rate	Amount
Principal - Vice President					
Wild, Scott	11/30/2024		1.00	205.00	205.00
Wild, Scott	12/7/2024		1.00	205.00	205.00
Wild, Scott	12/14/2024		1.00	205.00	205.00
CEI Project Manager					
Donchez, James	12/7/2024		1.00	175.00	175.00
CEI Inspector					
Lanh, Pong	12/7/2024		3.50	125.00	437.50
Lanh, Pong	12/28/2024		1.00	125.00	125.00
Totals			8.50		1,352.50
Total Labor					1,352.50

Billing Limits	Current	Prior	To-Date
Total Billings	1,352.50	112,558.25	113,910.75
Limit			115,000.00
Remaining			1,089.25

Total this Phase \$1,352.50

Phase 02 Progress Meetings

Billing Limits	Current	Prior	To-Date
Total Billings	0.00	36,887.00	36,887.00
Limit			37,080.00
Remaining			193.00

Total this Phase 0.00

Phase 03 CDD Tax Exempt Purchase Requisitions

Labor

			Hours	Rate	Amount
Principal - Vice President					
Wild, Scott	11/30/2024		1.00	205.00	205.00

Wild, Scott	12/7/2024	1.00	205.00	205.00
Wild, Scott	12/14/2024	1.00	205.00	205.00
Totals		3.00		615.00

Total Labor 615.00

Billing Limits		Current	Prior	To-Date
Total Billings		615.00	15,796.00	16,411.00
Limit				20,000.00
Remaining				3,589.00

Total this Phase 615.00

Phase 04 Owner Requested Plan Revisions

Billing Limits		Current	Prior	To-Date
Total Billings		0.00	24,616.25	24,616.25
Limit				25,000.00
Remaining				383.75

Total this Phase 0.00

Phase 05 Reimbursable Expenses

Expenses				
Mileage				214.40
Permits				100.00
Total Expenses			1.0 times	314.40

314.40

Billing Limits		Current	Prior	To-Date
Total Billings		314.40	11,732.01	12,046.41
Limit				15,000.00
Remaining				2,953.59

Total this Phase 314.40

Phase 06 Plat Coordination

Billing Limits		Current	Prior	To-Date
Total Billings		0.00	7,832.47	7,832.47
Limit				15,000.00
Remaining				7,167.53

Total this Phase 0.00

Total This Invoice 2,281.90

Outstanding Invoices

Number	Date	Balance
216486	10/31/2024	9,684.65
217112	11/27/2024	13,611.50
Total		23,296.15

Total Now Due 25,578.05

**St. Johns County BCC
Central Cashiering
Cashier # 24-074065**

Name : Trailmark Access Driveway

Trans Date: 12/16/2024 9:21:42 AM

Charges:

Description	Assoc	Assoc Key	Charge Amount
FIRE SERVICE CONSTR. REVIEW Trailmark Access Driveway	AP	NDR CSTPL-2024000104	\$25.00
NON DRC SITE PLAN REVIEW Trailmark Access Driveway	AP	NDR CSTPL-2024000104	\$75.00
			Total
			\$100.00

Payment:

Description	Order Id	Charge Amount
NXLX	192960514	\$100.00



Six Mile Creek Community Development District
6200 Lee Vista Boulevard Ste 300
Orlando, FL 32822

January 07, 2025

Invoice No: 217853

Total This Invoice \$6,860.00

Project 22471.03000 Trailmark Drive at Pacetti Road - Traffic Signal Design Services -WA#79

Professional Services rendered through December 28, 2024

Phase Lump Sum

	Fee	Percent Complete	Earned	Current Billing
1. Traffic Signal Design	41,200.00	90.00	37,080.00	4,120.00
2. Geotechnical Exploration & Testing				
A. ETM Coordination	3,000.00	90.00	2,700.00	300.00
B. Subconsultant	6,000.00	0.00	0.00	0.00
3. Mast Arm, Upright & Foundation-Structural Design				
A. ETM Coordination	3,000.00	90.00	2,700.00	300.00
B. Subconsultant	6,000.00	0.00	0.00	0.00
4. Signing & Pavement Markings	3,600.00	90.00	3,240.00	360.00
5. Utility Coordination	8,200.00	90.00	7,380.00	820.00
6. Sub-Utility Exploration & Associated Survey Tasks				
A. ETM Coordination	3,000.00	90.00	2,700.00	0.00
B. Subconsultant	6,000.00	90.00	5,400.00	0.00
7. Permitting Activities & Coordination with SJC	9,600.00	90.00	8,640.00	960.00
8. Post-Design Services	10,400.00	0.00	0.00	0.00
Total Fee	100,000.00		69,840.00	6,860.00
Total Fee				6,860.00
Total this Phase				\$6,860.00

Phase 09 Topographical Survey Allowance

Total Fee 10,000.00

Percent Complete 100.00

Total Fee

0.00

Total this Phase **0.00**

Total This Invoice **\$6,860.00**

Outstanding Invoices

Number	Date	Balance
217408	12/3/2024	8,060.00
Total		8,060.00

Total Now Due **\$14,920.00**

**St. Johns County BCC
Central Cashiering
Cashier # 24-070405**

Name : Traffic Signal - Trailmark Drive at Pacetti Road

Trans Date: 11/25/2024 10:09:45 AM

Charges:

Description	Assoc	Assoc Key	Charge Amount
SECOND RE-SUBMISSION Traffic Signal - Trailmark Drive at Pacetti Road	AP	RW CONST-2024000008	\$104.00
UTILITY PLAN REVIEW Traffic Signal - Trailmark Drive at Pacetti Road	AP	RW CONST-2024000008	\$264.00
		Total	\$368.00

Payment:

Description	Order Id	Charge Amount
NXLX	191933557	\$368.00

REQUISITION NO. 98
(2023 Acquisition and Construction Account)

SIX MILE CREEK COMMUNITY DEVELOPMENT DISTRICT
(ST. JOHNS COUNTY, FLORIDA)

\$10,515,000
Capital Improvement Revenue Bonds
Series 2023 (2023 Project Area)

The undersigned, an Authorized Officer of Six Mile Creek Community Development District (the "District") hereby submits the following requisition for disbursement under and pursuant to the terms of the Master Trust Indenture from the District to U.S. Bank Trust Company, National Association, as successor trustee (the "Trustee"), dated as of July 1, 2007 (the "Master Indenture"), as amended and supplemented by the Eleventh Supplemental Trust Indenture between the District and Trustee, dated as of June 1, 2023 (the Master Indenture as amended and supplemented is hereinafter referred to as the "Indenture") (all capitalized terms used herein shall have the meaning ascribed to such term in the Indenture):

- (A) Requisition Number: **98**
- (B) Name of Payee: **SES Environmental Resource**
3550 St. Johns Bluff Road South
Jacksonville, FL 32224
- (C) Amount Payable: **\$ 26,200.00**
- (D) Purpose for which paid or incurred (refer also to specific contract if amount is due and payable pursuant to a contract involving progress payments, or, state Costs of Issuance, if applicable):
Professional services related to Trailmark East Parcel Phase 3
Haul Road - Invoice 40770
- (E) Fund or Account and subaccount, if any, from which disbursement is to be made:
 - \$ 26,200.00 Assessment Area 2 – Phase 3C Subaccount
 - \$ _____ Assessment Area 3 – Phase 3 Subaccount

The undersigned hereby certifies that obligations in the stated amount set forth above have been incurred by the District, that each disbursement set forth above is a proper charge against the 2023 Acquisition and Construction Account and the subaccount, if any, referenced above, that each disbursement set forth above was incurred in connection with the acquisition and construction of the 2023 Project and each represents a Cost of the 2023 Project, and has not previously been paid.

The undersigned hereby further certifies that there has not been filed with or served upon the District notice of any lien, right to lien, or attachment upon, or claim affecting the right to receive payment of, any of the moneys payable to the Payee set forth above, which has not been released or will not be released simultaneously with the payment hereof.

The undersigned hereby further certifies that such requisition contains no item representing payment on account of any retained percentage which the District is at the date of such certificate entitled to retain.

If this requisition is for a disbursement from other than the Costs of Issuance Account or for payment of capitalized interest, there shall be attached a resolution of the Governing Body of the District approving this requisition or approving the specific contract with respect to which disbursements pursuant to this requirement are due and payable.

Attached hereto are originals of the invoice(s) from the vendor of the property acquired or the services rendered with respect to which disbursement is hereby requested.

**SIX MILE CREEK COMMUNITY
DEVELOPMENT DISTRICT**

By: _____
Chairperson, Board of Supervisors

**CONSULTING ENGINEER'S APPROVAL FOR NON-COST OF ISSUANCE AND
CAPITALIZED INTEREST REQUESTS ONLY**

If this requisition is for a disbursement from other than Capitalized Interest or Costs of Issuance, the undersigned Consulting Engineer hereby certifies that this disbursement is for a Cost of the 2023 Project and is consistent with: (i) the applicable acquisition or construction contract; (ii) the plans and specifications for the portion of the 2023 Project with respect to which such disbursement is being made; and, (iii) the report of the Consulting Engineer attached as an Exhibit to the Eleventh Supplemental Trust Indenture, as such report shall have been amended or modified on the date hereof.

By: Seth A. Wild
Consulting Engineer

3550 St. Johns Bluff Road South
Jacksonville, FL 32224
(904)285-1397

Six Mile Creek CDD
Mr Kern
7807 Baymeadows Road East
Suite 205
Jacksonville, FL 32256

Invoice number 40770
Date 12/31/2024

Project **123.25.033 TRAILMARK HAUL ROAD RESTORATION**

Professional Services provided through December 31, 2024

Description	Contract Amount	Prior Billed	Current Billed
Z99 Professional Services	42,700.00	0.00	26,200.00
Total	42,700.00	0.00	26,200.00

Invoice total **26,200.00**

Completed Haul Road restoration planting and completed baseline monitoring report.

REQUISITION NO. 94
(2023 Acquisition and Construction Account)

SIX MILE CREEK COMMUNITY DEVELOPMENT DISTRICT
(ST. JOHNS COUNTY, FLORIDA)

\$10,515,000
Capital Improvement Revenue Bonds
Series 2023 (2023 Project Area)

The undersigned, an Authorized Officer of Six Mile Creek Community Development District (the "District") hereby submits the following requisition for disbursement under and pursuant to the terms of the Master Trust Indenture from the District to U.S. Bank Trust Company, National Association, as successor trustee (the "Trustee"), dated as of July 1, 2007 (the "Master Indenture"), as amended and supplemented by the Eleventh Supplemental Trust Indenture between the District and Trustee, dated as of June 1, 2023 (the Master Indenture as amended and supplemented is hereinafter referred to as the "Indenture") (all capitalized terms used herein shall have the meaning ascribed to such term in the Indenture):

- (A) Requisition Number: **94**
- (B) **Wire Instructions;**
Ferguson Enterprises, LLC
Bank of America
900 W. Trade Street, Charlotte, NC 28173
Account name: Ferguson Enterprises, LLC
Account number:
ABA/routing number (ACHs only): ABA/routing
number (wires only): Swift Code (international
wires only): BOFAUS3N
- (C) Amount Payable: **\$ 34.00**
- (D) Purpose for which paid or incurred (refer also to specific contract if amount is due and payable pursuant to a contract involving progress payments, or, state Costs of Issuance, if applicable): **Direct Owner Purchase – Trailmark East Parcel Phase 3**
- (E) Fund or Account and subaccount, if any, from which disbursement is to be made:
 \$ 34.00 Assessment Area 2 – Phase 3C Subaccount
 \$ _____ Assessment Area 3 – Phase 3 Subaccount

The undersigned hereby further certifies that obligations in the stated amount set forth above have been incurred by the District, that each disbursement set forth above is a proper charge against the 2023 Acquisition and Construction Account and the subaccount, if any, referenced above, that each disbursement set forth above was incurred in connection with the acquisition and construction of the 2023 Project and each represents a Cost of the 2023 Project, and has not previously been paid.

The undersigned hereby further certifies that there has not been filed with or served upon the District notice of any lien, right to lien, or attachment upon, or claim affecting the right to receive payment of, any of the moneys payable to the Payee set forth above, which has not been released or will not be released simultaneously with the payment hereof.

The undersigned hereby further certifies that such requisition contains no item representing payment on account of any retained percentage which the District is at the date of such certificate entitled to retain.

If this requisition is for a disbursement from other than the Costs of Issuance Account or for payment of capitalized interest, there shall be attached a resolution of the Governing Body of the District approving this requisition or approving the specific contract with respect to which disbursements pursuant to this requirement are due and payable.

Attached hereto are originals of the invoice(s) from the vendor of the property acquired or the services rendered with respect to which disbursement is hereby requested.

**SIX MILE CREEK COMMUNITY
DEVELOPMENT DISTRICT**

By: _____
Gregg F. Kern
Chairperson, Board of Supervisors

**CONSULTING ENGINEER'S APPROVAL FOR NON-COST OF ISSUANCE AND
CAPITALIZED INTEREST REQUESTS ONLY**

If this requisition is for a disbursement from other than Capitalized Interest or Costs of Issuance, the undersigned Consulting Engineer hereby certifies that this disbursement is for a Cost of the 2023 Project and is consistent with: (i) the applicable acquisition or construction contract; (ii) the plans and specifications for the portion of the 2023 Project with respect to which such disbursement is being made; and, (iii) the report of the Consulting Engineer attached as an Exhibit to the Eleventh Supplemental Trust Indenture, as such report shall have been amended or modified on the date hereof.

By: Scott A. Wild
Consulting Engineer



WATERWORKS

9692 FLORIDA MINING BLVD W
 BUILDING #100
 JACKSONVILLE, FL 32257

Please contact with Questions: 904-268-2551

SIX MILE CREEK COMMUNITY DEVEL
 475 WEST TOWN PLACE STE 114
 TRLMARK EAST PH 3
 SAINT AUGUSTINE, FL 32092

INVOICE NUMBER	TOTAL DUE	CUSTOMER	PAGE
2122257	\$34.00	67455	1 of 1

**PLEASE REFER TO INVOICE NUMBER WHEN
 MAKING PAYMENT AND REMIT TO:**

FEL-JACKSONVILLE WW -#149
 PO BOX 100286
 ATLANTA, GA 30384-0286

MASTER ACCOUNT NUMBER: 907333

SHIP TO:

COUNTER PICK UP
 9692 FLORIDA MINING BLVD W
 BUILDING #100
 JACKSONVILLE, FL 32257

SHIP WHSE.	SELL WHSE.	TAX CODE	CUSTOMER ORDER NUMBER	SALESMAN	JOB NAME	INVOICE DATE	BATCH
149	149	FLE	ID TAGS	008	TRLMARK EAST PH 3	11/07/24	IO 114601
ORDERED	SHIPPED	ITEM NUMBER	DESCRIPTION	UNIT PRICE	UM	AMOUNT	
2	2	RBGVTMX	3 BRS GATE VLV ID - 8 ID TAGS SHOULD HAVE STEMS	17.000	EA	34.00	
			INVOICE SUB-TOTAL			34.00	
<p>LEAD LAW WARNING: IT IS ILLEGAL TO INSTALL PRODUCTS THAT ARE NOT "LEAD FREE" IN ACCORDANCE WITH US FEDERAL OR OTHER APPLICABLE LAW IN POTABLE WATER SYSTEMS ANTICIPATED FOR HUMAN CONSUMPTION. PRODUCTS WITH *NP IN THE DESCRIPTION ARE NOT LEAD FREE AND CAN ONLY BE INSTALLED IN NON-POTABLE APPLICATIONS. BUYER IS SOLELY RESPONSIBLE FOR PRODUCT SELECTION.</p>							

Due to the Thanksgiving holiday on Thursday, November 28th, please ensure all payments are submitted by Wednesday, November 27th.

TERMS: NET 10TH PROX	ORIGINAL INVOICE	TOTAL DUE	\$34.00
----------------------	------------------	-----------	---------

All past due amounts are subject to a service charge of 1.5% per month, or the maximum allowed by law, if lower. If Buyer fails to pay within terms, then in addition to other remedies, Buyer agrees to pay Seller all costs of collection, including reasonable attorney fees. Complete terms and conditions are available upon request or at <https://www.ferguson.com/content/website-info/terms-of-sale>, incorporated by reference. Seller may convert checks to ACH.

REQUISITION NO. 12
(2024 Acquisition and Construction Account)

SIX MILE CREEK COMMUNITY DEVELOPMENT DISTRICT
(ST. JOHNS COUNTY, FLORIDA)

\$5,790,000
Capital Improvement Revenue Bonds
Series 2024 (2024 Project Area)

The undersigned, an Authorized Officer of Six Mile Creek Community Development District (the "District") hereby submits the following requisition for disbursement under and pursuant to the terms of the Master Trust Indenture from the District to U.S. Bank Trust Company, National Association, as successor trustee (the "Trustee"), dated as of July 1, 2007 (the "Master Indenture"), as amended and supplemented by the Twelfth Supplemental Trust Indenture between the District and Trustee, dated as of October 1, 2024 (the Master Indenture as amended and supplemented is hereinafter referred to as the "Indenture") (all capitalized terms used herein shall have the meaning ascribed to such term in the Indenture):

- (A) Requisition Number: 12
- (B) Name of Payee: **Wire Transfer Instructions:**
Jax Utilities Management, Inc.
Truist Bank
214 North Tryon St.
Charlotte, NC 28202
ABA:
Beneficiary: JAX UTILITIES MANAGEMENT INC
(Business Account Title)
Account #:
Routing #:
- (C) Amount Payable: \$ 667,002.62 (\$192,825.42 - Series 2024 & \$474,177.20 Developer Funded)
- (D) Purpose for which paid or incurred (refer also to specific contract if amount is due and payable pursuant to a contract involving progress payments, or, state Costs of Issuance, if applicable):
Trailmark Phase 13 Application for Payment No. 10 (November 2024)
- (E) Fund or Account and subaccount, if any, from which disbursement is to be made:

2024 Acquisition and Construction Account

The undersigned hereby certifies that obligations in the stated amount set forth above have been incurred by the District, that each disbursement set forth above is a proper charge against the 2024 Acquisition and Construction Account and the subaccount, if any, referenced above, that

each disbursement set forth above was incurred in connection with the acquisition and construction of the 2024 Project and each represents a Cost of the 2024 Project, and has not previously been paid.

The undersigned hereby further certifies that there has not been filed with or served upon the District notice of any lien, right to lien, or attachment upon, or claim affecting the right to receive payment of, any of the moneys payable to the Payee set forth above, which has not been released or will not be released simultaneously with the payment hereof.

The undersigned hereby further certifies that such requisition contains no item representing payment on account of any retained percentage which the District is at the date of such certificate entitled to retain.

If this requisition is for a disbursement from other than the Costs of Issuance Account or for payment of capitalized interest, there shall be attached a resolution of the Governing Body of the District approving this requisition or approving the specific contract with respect to which disbursements pursuant to this requirement are due and payable.

Attached hereto or on file with the District are originals of the invoice(s) from the vendor of the property acquired or the services rendered with respect to which disbursement is hereby requested.

**SIX MILE CREEK COMMUNITY
DEVELOPMENT DISTRICT**

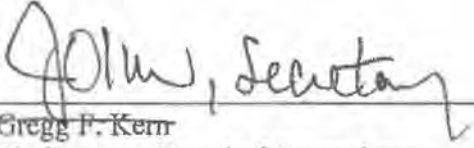
By: 
Gregg F. Kern
Chairperson, Board of Supervisors

**CONSULTING ENGINEER'S APPROVAL FOR NON-COST OF ISSUANCE AND
CAPITALIZED INTEREST REQUESTS ONLY**

If this requisition is for a disbursement from other than Capitalized Interest or Costs of Issuance, the undersigned Consulting Engineer hereby certifies that this disbursement is for a Cost of the 2024 Project and is consistent with: (i) the applicable acquisition or construction contract; (ii) the plans and specifications for the portion of the 2024 Project with respect to which such disbursement is being made; and, (iii) the report of the Consulting Engineer attached as an Exhibit to the Eleventh Supplemental Trust Indenture, as such report shall have been amended or modified on the date hereof.

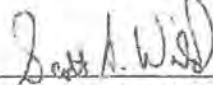
By: 
Consulting Engineer

APPLICATION AND CERTIFICATION FOR PAYMENT

AIA DOCUMENT G702



FROM (CONTRACTOR):
Jax Utilities Management, Inc
 5465 Verna Boulevard
 Jacksonville, FL 32205

TO (OWNER):
Six Mile Creek Investment Group
 c/o England-Thims & Miller, Inc.
 14775 Old St. Augustine Road
 Jacksonville, FL 32258

APPLICATION NO: 10

PERIOD TO: November 25, 2024

PROJECT: Trailmark PH 13

CONTRACT FOR:
 Underground Infrastructure

Reviewed and
 Accurate to Site
 Conditions.
 Pong L. 12-4-24

CONTRACTORS APPLICATION FOR PAYMENT

CHANGE ORDER SUMMARY		
Change Orders approved in previous months by Owner	ADDITIONS	DEDUCTIONS
TOTAL	0.00	0.00
Approved this Month		
Number Date Approved		
1		(1,152,798.26)
2	19,278.00	
3		
4		
5		
6		
7		
8		
9		
TOTALS	19,278.00	(1,152,798.26)
Net change by Change Orders	(1,133,520.26)	

The undersigned Contractor certifies that to the best of the Contractor's knowledge, Information and belief the Work covered by this Application for Payment has been completed in accordance with the Contract Documents, that all amounts have been paid for by the Contractor for Work for which previous Certificates for Payment were issued and payments received from the Owner, and the current payment shown herein is now due.

Notary Public State of Florida
 Anne-Maria James
 My Commission #M 278959
 EXP. 8/17/2028

Application is made for payment, as shown below, in connection with the Contract. Continuation sheet, AIA Document G703, is attached.

1. ORIGINAL CONTRACT SUM	\$8,763,666.00
2. Net Change by Change Orders	-\$1,133,520.26
3. CONTRACT SUM TO DATE (LINE 1 +,- 2)	\$7,630,145.74
4. TOTAL COMPLETED AND STORED TO DATE	\$5,920,944.74
5. RETAINAGE	
a. 5% % (Column D+E on G703)	
Total retainage (Line 5a, or Total in Column J of G703)	\$296,047.24
6. TOTAL EARNED LESS RETAINAGE (Line 4 less Line 5 Total)	\$5,624,897.50
7. LESS PREVIOUS CERTIFICATES FOR PAYMENT (Line 6 from prior Certificate)	\$4,957,894.88
8. CURRENT PAYMENT DUE	\$667,002.62
9. BALANCE TO FINISH, PLUS RETAINAGE (Line 3 less Line 6)	\$2,005,248.24

State of: Florida County of: Duval
 Subscribed and sworn before me this 25th day of November, 2024
 Notary Public: [Signature]
 My Commission expires: August 17 2028

CONTRACTOR: Jax Utilities Management, Inc
 By: [Signature] Date: 11/25/2024

AMOUNT CERTIFIED: \$667,002.62
 ENGINEER: England-Thims & Miller, Inc.
 BY: [Signature] DATE: 12/9/2024

ENGINEERS CERTIFICATE FOR PAYMENT
 In accordance with the Contract Documents, based on on-site observations and the data comprising the above application, the Engineer certifies to the Owner that to the best of the Engineers knowledge, information and belief the Work has progressed as indicated, the quality of the Work is in accordance with the Contract Documents, and the Contractor is entitled to payment of the AMOUNT CERTIFIED.

This Certificate is not negotiable. The AMOUNT CERTIFIED is payable only to the Contractor named herein. Issuance, payment and acceptance of payments are without prejudice to any rights of the Owner or Contractor under this Contract

Project Number: 21-696
 Project Name: Trailmark 13
 Owner Name: ET&M
 Contract Number:
 For Month Ending: 11/25/2024

Period Ending: 11/25/24
 Variance: \$0.00
 Projected Final: \$7,632,585.74
 Billings To Date: \$5,920,944.74
 Remaining Billings: \$1,710,641.00

Bid Items	Original Contract Amt				Prev. Quantity	Current		Materials Amount	To Date		Remaining		Projected Final		% Complete	Variance at Completion	
	Qty	UM	Unit Price	L&E Total Amount		Quantity	Amount		Quantity	Amount	Quantity	Amount	Quantity	Amount		Quantity	Amount
Mobilizations	1.00	LS	74,000.00	\$ 74,000.00	1.00	\$ -	-	-	1.00	\$ 74,000.00	-	\$ -	1.00	\$ 74,000.00	100%	0.000	\$ -
Survey	1.00	LS	49,500.00	\$ 49,500.00	0.90	\$ -	-	-	0.90	\$ 44,550.00	0.10	\$ 4,950.00	1.00	\$ 49,500.00	90%	0.000	\$ -
MDT	1.00	LS	3,000.00	\$ 3,000.00	1.00	\$ -	-	-	1.00	\$ 3,000.00	-	\$ -	1.00	\$ 3,000.00	100%	0.000	\$ -
Demolition	1.00	LS	25,000.00	\$ 25,000.00	1.00	\$ -	-	-	1.00	\$ 25,000.00	-	\$ -	1.00	\$ 25,000.00	100%	0.000	\$ -
Total				\$ 151,500.00		\$ -	-	-	\$ 144,550.00		\$ 4,950.00		\$ 531,500.00	96.73%		\$ -	
CLEARING AND GRUBBING																	
Clearing	45.00	AC	6,600.00	\$ 297,000.00	45.00	\$ -	-	-	45.00	\$ 297,000.00	-	\$ -	45.00	\$ 297,000.00	100%	0.000	\$ -
Scrubbing	45.00	AC	3,400.00	\$ 153,000.00	45.00	\$ -	-	-	45.00	\$ 153,000.00	-	\$ -	45.00	\$ 153,000.00	100%	0.000	\$ -
Total				\$ 450,000.00		\$ -	-	-	\$ 450,000.00		\$ -		\$ 450,000.00	100.00%		\$ -	
UNSUITABLE MATERIAL																	
Remove & Replace Unsuitable	27,000.00	CY	11.00	\$ 297,000.00	27,000.00	\$ -	-	-	27,000.00	\$ 297,000.00	-	\$ -	27,000.00	\$ 297,000.00	100%	0.000	\$ -
Total				\$ 297,000.00		\$ -	-	-	\$ 297,000.00		\$ -		\$ 297,000.00	100.00%		\$ -	
STORMWATER MNGT.																	
Pond Excavation	74,600.00	CY	3.75	\$ 279,750.00	68,020.00	\$ 258,075.00	-	-	74,600.00	\$ 279,750.00	-	\$ -	74,600.00	\$ 279,750.00	100%	0.000	\$ -
Dewatering	1.00	LS	39,000.00	\$ 39,000.00	0.65	\$ 25,350.00	-	-	1.00	\$ 39,000.00	-	\$ -	1.00	\$ 39,000.00	100%	0.000	\$ -
Total				\$ 318,750.00		\$ 283,425.00			\$ 318,750.00		\$ -		\$ 318,750.00			\$ -	
EARTHWORK																	
Roadway Exc. - Import - Rough Grade	1.00	CY	65,000.00	\$ 65,000.00	1.00	\$ -	-	-	1.00	\$ 65,000.00	-	\$ -	1.00	\$ 65,000.00	100%	0.000	\$ -
R/W Dress Up	11,900.00	LF	2.00	\$ 23,800.00	-	\$ -	-	-	-	\$ -	11,900.00	\$ 23,800.00	11,900.00	\$ 23,800.00	0%	0.000	\$ -
Misc. Site & Swale Grading	1.00	LS	18,000.00	\$ 18,000.00	-	\$ -	-	-	-	\$ -	1.00	\$ 18,000.00	1.00	\$ 18,000.00	0%	0.000	\$ -
Lot Fill from Site	71,600.00	CY	1.25	\$ 89,500.00	67,070.00	\$ 7,380.50	-	-	74,600.00	\$ 93,250.00	-	\$ -	74,600.00	\$ 93,250.00	100%	0.000	\$ -
Lot Fill - From Rec Pond	165,400.00	CY	5.50	\$ 909,700.00	148,199.40	\$ 815,093.30	-	-	165,400.00	\$ 909,700.00	-	\$ -	165,400.00	\$ 909,700.00	100%	0.000	\$ -
Spread & Compact	165,400.00	CY	1.20	\$ 198,480.00	148,189.40	\$ 177,827.28	-	-	165,400.00	\$ 198,480.00	-	\$ -	165,400.00	\$ 198,480.00	100%	0.000	\$ -
Lot Grade & Dress Up	1.00	LS	39,000.00	\$ 39,000.00	-	\$ -	-	-	-	\$ -	1.00	\$ 39,000.00	1.00	\$ 39,000.00	0%	0.000	\$ -
Total				\$ 1,347,280.00		\$ 723,977.02			\$ 1,264,430.00		\$ 588,800.00		\$ 1,347,280.00	84.80%		\$ -	
ROADWAY CONSTRUCTION																	
Misc. Curb (incl backfill)	11,900.00	LF	16.95	\$ 200,400.00	-	\$ -	-	-	-	\$ -	11,900.00	\$ 200,400.00	11,900.00	\$ 200,400.00	0%	0.000	\$ -
6" Roadway Base	14,650.00	SY	18.80	\$ 275,420.00	-	\$ -	-	-	-	\$ -	14,650.00	\$ 275,420.00	14,650.00	\$ 275,420.00	0%	0.000	\$ -
12" Stabilized Subgrade	17,300.00	SY	9.70	\$ 167,810.00	-	\$ -	-	-	-	\$ -	17,300.00	\$ 167,810.00	17,300.00	\$ 167,810.00	0%	0.000	\$ -
Asphalt 1 1/2" Hot Bit SP 12.5	14,650.00	SY	12.00	\$ 175,800.00	-	\$ -	-	-	-	\$ -	14,650.00	\$ 175,800.00	14,650.00	\$ 175,800.00	0%	0.000	\$ -
Forms	14,650.00	SY	3.00	\$ 43,950.00	-	\$ -	-	-	-	\$ -	14,650.00	\$ 43,950.00	14,650.00	\$ 43,950.00	0%	0.000	\$ -
Pavement Markings	1.00	LS	10,000.00	\$ 10,000.00	-	\$ -	-	-	-	\$ -	1.00	\$ 10,000.00	1.00	\$ 10,000.00	0%	0.000	\$ -
Signs	50.00	SY	80.00	\$ 4,000.00	-	\$ -	-	-	-	\$ -	50.00	\$ 4,000.00	50.00	\$ 4,000.00	0%	0.000	\$ -
ADA Ramps	6.00	EA	2,500.00	\$ 15,000.00	-	\$ -	-	-	-	\$ -	6.00	\$ 15,000.00	6.00	\$ 15,000.00	0%	0.000	\$ -
Total				\$ 682,180.00		\$ -			\$ -		\$ 587,380.00		\$ 682,180.00	0.00%		\$ -	
STORM DRAINAGE SYSTEM																	
15" RCP	469.00	LF	38.31	\$ 17,966.40	469.00	\$ -	-	9,233.60	469.00	\$ 17,966.40	-	\$ -	469.00	\$ 17,966.40	100%	0.000	\$ -
18" RCP	528.00	LF	55.45	\$ 29,278.80	528.00	\$ -	-	10,618.28	528.00	\$ 29,278.80	-	\$ -	528.00	\$ 29,278.80	100%	0.000	\$ -
24" RCP	855.00	LF	83.35	\$ 71,597.60	855.00	\$ -	-	17,119.40	855.00	\$ 71,597.60	-	\$ -	855.00	\$ 71,597.60	100%	0.000	\$ -
30" RCP	422.00	LF	105.82	\$ 44,656.40	422.00	\$ -	-	8,531.20	422.00	\$ 44,656.40	-	\$ -	422.00	\$ 44,656.40	100%	0.000	\$ -
36" RCP	963.00	LF	177.26	\$ 170,820.60	963.00	\$ -	-	34,164.06	963.00	\$ 170,820.60	-	\$ -	963.00	\$ 170,820.60	100%	0.000	\$ -
42" RCP	211.00	LF	291.80	\$ 61,669.80	211.00	\$ -	-	42,339.60	211.00	\$ 61,669.80	-	\$ -	211.00	\$ 61,669.80	100%	0.000	\$ -
48" RCP	174.00	LF	264.88	\$ 45,889.20	174.00	\$ -	-	34,974.00	174.00	\$ 45,889.20	-	\$ -	174.00	\$ 45,889.20	100%	0.000	\$ -
54" RCP	37.00	LF	248.95	\$ 9,211.00	37.00	\$ -	-	7,424.40	37.00	\$ 9,211.00	-	\$ -	37.00	\$ 9,211.00	100%	0.000	\$ -
12" x 18" RCP	25.00	LF	95.00	\$ 2,375.00	25.00	\$ -	-	617.50	25.00	\$ 2,375.00	-	\$ -	25.00	\$ 2,375.00	100%	0.000	\$ -
12" / 15" / 18" MES	3.00	EA	849.00	\$ 2,547.00	3.00	\$ -	-	1,053.00	3.00	\$ 2,547.00	-	\$ -	3.00	\$ 2,547.00	100%	0.000	\$ -
24" MES	1.00	EA	837.00	\$ 837.00	1.00	\$ -	-	1,393.00	1.00	\$ 837.00	-	\$ -	1.00	\$ 837.00	100%	0.000	\$ -
36" MES	3.00	EA	390.00	\$ 1,140.00	3.00	\$ -	-	7,110.00	3.00	\$ 1,140.00	-	\$ -	3.00	\$ 1,140.00	100%	0.000	\$ -
48" MES	1.00	EA	26,000.00	\$ 26,000.00	1.00	\$ -	-	26,000.00	1.00	\$ 26,000.00	-	\$ -	1.00	\$ 26,000.00	100%	0.000	\$ -
54" MES	1.00	EA	39,000.00	\$ 39,000.00	1.00	\$ -	-	39,000.00	1.00	\$ 39,000.00	-	\$ -	1.00	\$ 39,000.00	100%	0.000	\$ -
Manholes	3.00	EA	2,333.00	\$ 6,999.00	3.00	\$ -	-	14,607.00	3.00	\$ 6,999.00	-	\$ -	3.00	\$ 6,999.00	100%	0.000	\$ -
Curb Inlets	19.00	EA	3,524.32	\$ 66,962.08	19.00	\$ -	-	67,938.00	19.00	\$ 66,962.08	-	\$ -	19.00	\$ 66,962.08	100%	0.000	\$ -
Double Curb Inlets	10.00	EA	5,954.30	\$ 59,543.00	10.00	\$ -	-	58,858.00	10.00	\$ 59,543.00	-	\$ -	10.00	\$ 59,543.00	100%	0.000	\$ -

Project Number: 21-686
 Project Name: Trailmark 13
 Owner Name: ET&M
 Contract Number:
 For Month Ending: 11/25/2024

Period Ending: 11/25/24
 Variance: \$0.00
 Projected Final: \$7,631,585.74
 Billings To Date: \$5,920,946.74
 Remaining Billings: \$2,710,639.00

Bid Items	Original Contract Amt				Prev. Quantity	Current		Materials Amount	To Date		Remaining		Projected Final		%	Projection vs. Original	
	Qty	UH	Unit Price	(\$ Total Amount)		Quantity	Amount		Quantity	Amount	Quantity	Amount	Quantity	Amount		Complete	Quantity
Type C Inlets	3,000	EA	\$ 3,890.00	\$ 11,670.00	3,000	\$ -	4,620.00	3,000	\$ 16,200.00	-	\$ -	3,000	\$ 16,200.00	100%	0.000	\$ -	
Type E Inlets	3,000	EA	\$ 11,830.00	\$ 35,490.00	3,000	\$ -	15,185.00	3,000	\$ 50,775.00	-	\$ -	3,000	\$ 50,775.00	100%	0.000	\$ -	
Type H Inlets	1,000	EA	\$ 23,083.00	\$ 23,083.00	1,000	\$ -	26,917.00	1,000	\$ 48,400.00	-	\$ -	1,000	\$ 49,400.00	100%	0.000	\$ -	
Underdrain Stub	1,160,000	LF	\$ 31.19	\$ 36,186.00	-	\$ -	7,894.00	-	\$ 7,894.00	1,160,000	\$ 36,186.00	1,160,000	\$ 44,080.00	100%	0.000	\$ -	
Unsuitable Material	3,450,000	CY	\$ 24.00	\$ 82,800.00	3,450,000	\$ -	-	3,450,000	\$ 86,600.00	-	\$ -	3,450,000	\$ 96,600.00	100%	0.000	\$ -	
Adjustments	41,000	LF	\$ 800.00	\$ 32,800.00	-	\$ -	-	-	\$ -	41,000	\$ 32,800.00	41,000	\$ 32,800.00	0%	0.000	\$ -	
TV Storm Drain	3,784,000	LF	\$ 18.00	\$ 68,112.00	-	\$ -	-	-	\$ -	3,784,000	\$ 68,112.00	3,784,000	\$ 68,112.00	0%	0.000	\$ -	
Big Res Ditch Paving	1,000	LF	\$ 10,500.00	\$ 10,500.00	-	\$ -	-	-	\$ -	1,000	\$ 10,500.00	1,000	\$ 10,500.00	0%	0.000	\$ -	
Total				\$ 190,194.59		\$ -	\$ 412,817.40		\$ 1,225,381.00		\$ 247,519.00		\$ 51,172,979.00	89.25%		\$ -	
ROADWAY UNDERDRAIN																	
Roadway Underdrain	0,000	LF	\$ 38.20	\$ -	-	\$ -	-	-	\$ -	-	\$ -	-	\$ -	0%	0.000	\$ -	
Total				\$ -		\$ -	\$ -		\$ -		\$ 50.00		\$ 50.00	0%	0.000	\$ -	
PAVING & DRAINAGE AS-BUILTS																	
Paving & Drainage As-Builts	1,000	LS	\$ 45,000.00	\$ 45,000.00	-	\$ -	-	-	\$ -	1,000	\$ 45,000.00	1,000	\$ 45,000.00	0%	0.000	\$ -	
Total				\$ 45,000.00		\$ -	\$ -		\$ -		\$ 45,000.00		\$ 45,000.00	0.00%		\$ -	
SEWAGE WATER DISTRIBUTION SYSTEM																	
8" WM	5,192,000	LF	\$ 53.94	\$ 278,947.50	5,192,000	\$ -	159,180.50	5,192,000	\$ 436,128.00	-	\$ -	5,192,000	\$ 436,128.00	100%	0.000	\$ -	
4" WM	278,000	LF	\$ 64.59	\$ 18,055.22	278,000	\$ -	2,611.80	278,000	\$ 15,012.00	-	\$ -	278,000	\$ 15,012.00	100%	0.000	\$ -	
2" WM	632,000	LF	\$ 16.80	\$ 10,617.60	632,000	\$ -	1,393.00	632,000	\$ 12,908.00	-	\$ -	632,000	\$ 12,908.00	100%	0.000	\$ -	
Tile Ins	2,000	EA	\$ 7,400.00	\$ 14,800.00	2,000	\$ -	-	2,000	\$ 14,800.00	-	\$ -	2,000	\$ 14,800.00	100%	0.000	\$ -	
10" Road Crossings	2,000	EA	\$ 6,345.00	\$ 12,690.00	2,000	\$ -	6,310.00	2,000	\$ 19,000.00	-	\$ -	2,000	\$ 19,000.00	100%	0.000	\$ -	
PH w/ GV	12,000	EA	\$ 2,349.00	\$ 28,188.00	12,000	\$ -	48,812.00	12,000	\$ 76,800.00	-	\$ -	12,000	\$ 76,800.00	100%	0.000	\$ -	
Flushing Hydrants	3,000	EA	\$ 1,925.00	\$ 5,775.00	3,000	\$ -	5,625.00	3,000	\$ 11,400.00	-	\$ -	3,000	\$ 11,400.00	100%	0.000	\$ -	
Services	192,000	EA	\$ 406.72	\$ 78,090.24	192,000	\$ -	67,830.00	192,000	\$ 145,920.00	-	\$ -	192,000	\$ 145,920.00	100%	0.000	\$ -	
Test & Chlorinate	6,227,000	LF	\$ 2.65	\$ 16,502.55	-	\$ -	-	-	\$ -	6,227,000	\$ 16,502.55	6,227,000	\$ 16,502.55	0%	0.000	\$ -	
Adjustments	1,000	LS	\$ 12,900.00	\$ 12,900.00	-	\$ -	-	-	\$ -	1,000	\$ 12,900.00	1,000	\$ 12,900.00	0%	0.000	\$ -	
Total				\$ 328,812.70		\$ -	\$ 291,582.30		\$ 711,008.00		\$ 218,137.00		\$ 576,195.00	97.43%		\$ -	
SEWAGE SEWER SYSTEM																	
8" Sewer Main	5,505,000	LF	\$ 61.40	\$ 338,007.00	5,505,000	\$ -	140,926.06	5,505,000	\$ 478,933.00	-	\$ -	5,505,000	\$ 478,933.00	100%	0.000	\$ -	
Manholes	28,000	EA	\$ 6,013.07	\$ 168,366.00	28,000	\$ -	148,094.00	28,000	\$ 316,400.00	-	\$ -	28,000	\$ 316,400.00	100%	0.000	\$ -	
Services	188,000	EA	\$ 403.75	\$ 75,903.00	188,000	\$ -	84,341.00	188,000	\$ 160,083.00	-	\$ -	188,000	\$ 160,083.00	100%	0.000	\$ -	
Dewester	1,000	LS	\$ 162,000.00	\$ 162,000.00	1,000	\$ -	-	1,000	\$ 162,000.00	-	\$ -	1,000	\$ 162,000.00	100%	0.000	\$ -	
Adjustments	1,000	LS	\$ 29,700.00	\$ 29,700.00	-	\$ -	-	-	\$ -	1,000	\$ 29,700.00	1,000	\$ 29,700.00	0%	0.000	\$ -	
TV Testing	6,263,000	LF	\$ 10.00	\$ 62,630.00	-	\$ -	-	-	\$ -	6,263,000	\$ 62,630.00	6,263,000	\$ 62,630.00	0%	0.000	\$ -	
Connect To Existing	2,000	EA	\$ 7,500.00	\$ 15,000.00	2,000	\$ -	-	2,000	\$ 15,000.00	-	\$ -	2,000	\$ 15,000.00	100%	0.000	\$ -	
Backflow & Backfill	1,000	LS	\$ 26,000.00	\$ 26,000.00	1,000	\$ -	-	1,000	\$ 26,000.00	-	\$ -	1,000	\$ 26,000.00	100%	0.000	\$ -	
Remove & Replace Unsuit. Material	5,400,000	CY	\$ 28.00	\$ 151,200.00	5,400,000	\$ -	-	5,400,000	\$ 151,200.00	-	\$ -	5,400,000	\$ 151,200.00	100%	0.000	\$ -	
Total				\$ 682,646.50		\$ -	\$ 372,902.06		\$ 1,309,618.00		\$ 282,130.00		\$ 576,195.00	93.41%		\$ -	
SEWAGE LIFT STATION & FORCEMAIN																	
4" Force Main	2,172,000	LF	\$ 91.82	\$ 199,425.00	2,172,000	\$ -	22,540.50	2,172,000	\$ 91,224.00	-	\$ -	2,172,000	\$ 91,224.00	100%	0.000	\$ -	
ARY Valve & Vault	1,000	LS	\$ 2,071.00	\$ 2,071.00	1,000	\$ -	7,129.00	1,000	\$ 9,300.00	-	\$ -	1,000	\$ 9,300.00	100%	0.000	\$ -	
Testing	1,000	LF	\$ 2,700.00	\$ 2,700.00	-	\$ -	-	-	\$ -	1,000	\$ 2,700.00	1,000	\$ 2,700.00	0%	0.000	\$ -	
Wet Well	1,000	LS	\$ 239,007.00	\$ 239,007.00	1,000	\$ -	43,992.00	1,000	\$ 289,000.00	-	\$ -	1,000	\$ 289,000.00	100%	0.000	\$ -	
Pumps & Panel	1,000	LS	\$ 167,000.00	\$ 167,000.00	0.30	\$ 49.50	61,750.00	0.55	\$ 91,850.00	0.45	\$ 75,150.00	1,000	\$ 167,000.00	55%	6.000	\$ -	
Force	1,000	LF	\$ 21,000.00	\$ 21,000.00	-	\$ -	-	-	\$ -	1,000	\$ 21,000.00	1,000	\$ 21,000.00	0%	0.000	\$ -	
Concrete & Stewwork	1,000	LS	\$ 55,700.00	\$ 55,700.00	-	\$ -	-	-	\$ -	1,000	\$ 55,700.00	1,000	\$ 55,700.00	0%	0.000	\$ -	
Electric	1,000	LF	\$ 56,400.00	\$ 56,400.00	-	\$ -	-	-	\$ -	1,000	\$ 56,400.00	1,000	\$ 56,400.00	0%	0.000	\$ -	
Start Up & Testing	1,000	LS	\$ 9,600.00	\$ 9,600.00	-	\$ -	-	-	\$ -	1,000	\$ 9,600.00	1,000	\$ 9,600.00	0%	0.000	\$ -	
Total				\$ 522,143.50		\$ -	\$ 72,642.50		\$ 475,374.00		\$ 230,550.00		\$ 585,834.00	48.30%		\$ -	
WATER & SEWER AS-BUILTS																	
Water & Sewer As-Builts	1,000	LS	\$ 44,000.00	\$ 44,000.00	-	\$ -	-	-	\$ -	1,000	\$ 44,000.00	1,000	\$ 44,000.00	0%	0.000	\$ -	
Total				\$ 44,000.00		\$ -	\$ -		\$ -		\$ 44,000.00		\$ 44,000.00	0.00%		\$ -	
SEWER - IRRIG. - ELEC. - TELE- CATV																	
2.5"	4,000,000	LF	\$ 12.00	\$ 48,000.00	-	\$ -	3,158.00	3,158,000	\$ 37,896.00	842,000	\$ 10,104.00	4,000,000	\$ 48,000.00	79%	0.000	\$ -	

Project Number: 21-43 E
 Project Name: Trailmark 13
 Owner Name: ETRM
 Contract Number:
 For Month Ending: 11/25/2024

Period Ending: 11/25/24
 Variance: \$0.00
 Projected Final: \$7,431,585.74
 Billings To Date: \$5,829,944.79

Remaining Billings: \$1,701,641.00

Bid Items	Original Contract Amt		Unit Price	Lot Total Amount	Pick Quantity	Current		Material Amount	To Date		Remaining		Projected Final		Variance at Completion	Projection vs. Original
	Qty	UM				Quantity	Amount		Quantity	Amount	Quantity	Amount	Quantity	Amount		
3"	3,500,000	LF	\$ 14.00	\$ 49,000.00	3,500,000	\$ 49,000.00	2,785,000	\$ 38,990.00	715,000	\$ 10,010.00	3,500,000	\$ 49,000.00	80%	0,000	\$ -	
4"	4,500,000	LF	\$ 16.00	\$ 72,000.00	3,840,000	\$ 61,440.00	3,430,000	\$ 54,880.00	1,340,000	\$ 21,440.00	4,500,000	\$ 72,000.00	70%	0,000	\$ -	
2"	3,000,000	LF	\$ 18.00	\$ 54,000.00	2,895,000	\$ 52,110.00	2,055,000	\$ 37,005.00	840,000	\$ 15,097.00	3,000,000	\$ 54,000.00	67%	0,000	\$ -	
Total				\$ 223,000.00		\$ 166,464.00		\$ 144,454.00		\$ 144,454.00		\$ 538,548.00		5,223,000.00	\$ 73,253%	\$ -

Project Number: 23-636
 Project Name: Trailmark 13
 Owner Name: ET&M
 Contract Number:
 For Month Ending: 11/25/2024

Period Ending: 11/25/24
 Variance: \$0.00
 Projected Final: \$7,631,585.74
 Billings To Date: \$5,920,944.74
 Remaining Billings: \$1,710,641.00

Bid Items	Original Contract Amt				Prev. Quantity	Current		Materials Amount	To Date		Remaining		Projected Final		% Complete	Projection vs. Original	
	Qty	UM	Unit Price	L&E Total Amount		Quantity	Amount		Quantity	Amount	Quantity	Amount	Quantity	Amount		Quantity	Amount
FPI ELEC. ALLOWANCE																	
Per Bid Docs	1.000	LS	\$ 175,000.00	\$ 175,000.00	-	1.00	\$ 175,000.00	-	1.00	\$ 175,000.00	-	\$ -	1.00	\$ 175,000.00	100%	0.000	\$ -
Total				\$ 175,000.00			\$ 175,000.00			\$ 175,000.00		\$ 50.00		\$ 175,000.00	100.00%		\$ -
SEEDING & SOD																	
Seeding: Lets	153,000.000	SY	\$ 0.50	\$ 76,500.00	-	153,000.00	\$ 76,500.00	-	153,000.00	\$ 76,500.00	-	\$ -	153,000.00	\$ 76,500.00	100%	0.000	\$ -
Seeding: R/W	19,000.000	SY	\$ 0.50	\$ 9,500.00	-	-	\$ -	-	-	\$ -	19,000.00	\$ 9,500.00	19,000.00	\$ 9,500.00	0%	0.000	\$ -
Sod Ponds	20,500.000	SY	\$ 4.00	\$ 82,000.00	-	20,500.00	\$ 82,000.00	-	20,500.00	\$ 82,000.00	-	\$ -	20,500.00	\$ 82,000.00	100%	0.000	\$ -
Sod Back of Lets & Swales	10,900.000	SY	\$ 4.00	\$ 43,600.00	-	-	\$ -	-	-	\$ -	10,900.00	\$ 43,600.00	10,900.00	\$ 43,600.00	0%	0.000	\$ -
Back of Curb & Edge of Pavement	2,100.000	SY	\$ 4.00	\$ 8,400.00	-	-	\$ -	-	-	\$ -	2,100.00	\$ 8,400.00	2,100.00	\$ 8,400.00	0%	0.000	\$ -
Total				\$ 220,000.00			\$ 268,500.00			\$ 268,500.00		\$ 561,500.00		\$ 220,000.00	72.65%		\$ -
EROSION CONTROL																	
Erosion Control NPDES	1.000	LS	\$ 28,000.00	\$ 28,000.00	0.90	0.05	\$ 200.00	-	0.95	\$ 27,100.00	0.05	\$ 800.00	1.00	\$ 28,000.00	95%	0.000	\$ -
Site Fence	11,000.000	LF	\$ 3.50	\$ 38,500.00	11,000.00	-	\$ -	-	11,000.00	\$ 38,500.00	-	\$ -	11,000.00	\$ 38,500.00	100%	0.000	\$ -
Construction Entrance	2.000	LS	\$ 5,000.00	\$ 10,000.00	2.00	-	\$ -	-	2.00	\$ 10,000.00	-	\$ -	2.00	\$ 10,000.00	100%	0.000	\$ -
Inlet Protection	44.000	EA	\$ 440.00	\$ 19,360.00	-	-	\$ -	-	-	\$ -	44.00	\$ 19,360.00	44.00	\$ 19,360.00	0%	0.000	\$ -
Turbidity Control	1.000	LS	\$ 76,000.00	\$ 76,000.00	0.75	0.25	\$ 7,600.00	-	0.85	\$ 64,600.00	0.15	\$ 11,400.00	1.00	\$ 76,000.00	83%	0.000	\$ -
Total				\$ 161,800.00			\$ 8,500.00			\$ 130,200.00		\$ 531,660.00		\$ 161,800.00	80.44%		\$ -
STORMWATER POLLUTION PLAN																	
SWPPP	1.000	LS	\$ 12,000.00	\$ 12,000.00	0.90	-	\$ -	-	0.90	\$ 10,800.00	0.10	\$ 1,200.00	1.00	\$ 12,000.00	90%	0.000	\$ -
Total				\$ 12,000.00			\$ -			\$ 10,800.00		\$ 1,200.00		\$ 12,000.00	90.00%		\$ -
BOND																	
Payment & Performance Bonds	1.000	LS	\$ 137,000.00	\$ 137,000.00	1.00	-	\$ -	-	1.00	\$ 137,000.00	-	\$ -	1.00	\$ 137,000.00	100%	0.000	\$ -
Contractor Warrant	1.000	LS	\$ 21,000.00	\$ 21,000.00	-	-	\$ -	-	-	\$ -	1.00	\$ 21,000.00	1.00	\$ 21,000.00	0%	0.000	\$ -
Total				\$ 258,000.00			\$ -			\$ 137,000.00		\$ 21,000.00		\$ 258,000.00	96.71%		\$ -
RETAINING WALL																	
Retaining Wall	1.000	LS	\$ 57,000.00	\$ 57,000.00	1.00	-	\$ -	-	1.00	\$ 57,000.00	-	\$ -	1.00	\$ 57,000.00	100%	0.000	\$ -
Total				\$ 57,000.00			\$ -			\$ 57,000.00		\$ 50.00		\$ 57,000.00	100.00%		\$ -
CHANGE ORDERS																	
	Qty	UM	Unit Price	Total Amount	To Date Quantity		Amount		To Date Quantity	Amount	Remaining Quantity	Amount	Projected Final Quantity	Amount	% Complete	Projection vs. Original Quantity	Amount
Change Order 1																	
ODP American Precast	1.000	LS	\$ (397,207.00)	\$ (397,207.00)	1.00	-	\$ -	-	1.00	\$ (397,207.00)	-	\$ -	1.00	\$ (397,207.00)	100%	0.000	\$ -
ODP Ferguson	1.000	LS	\$ (754,151.26)	\$ (754,151.26)	1.00	-	\$ -	-	1.00	\$ (754,151.26)	-	\$ -	1.00	\$ (754,151.26)	100%	0.000	\$ -
Change Order 2																	
Reobce MH Rise In TM 11	1.000	LS	\$ 19,278.00	\$ 19,278.00	1.00	-	\$ -	-	1.00	\$ 19,278.00	-	\$ -	1.00	\$ 19,278.00	100%	0.000	\$ -
Change Order Totals				\$ (1,132,080.26)			\$ 50.00	0.000		\$ -1,132,080.26		\$ -		\$ (1,132,080.26)			\$ -

	\$6,480,227.48	\$702,106.02	\$1,151,358.26	\$ 5,920,944.74	\$3,710,641.00	\$7,631,585.74
--	----------------	--------------	----------------	-----------------	----------------	----------------

Total Contract w/ Materials	\$7,631,585.74
-----------------------------	----------------

All Change Orders w/ Materials	-\$1,132,080.26
--------------------------------	-----------------

PARTIAL RELEASE OF CLAIM OF LIEN

The undersigned lienor, in consideration of payment in the amount of \$667,002.62 hereby partially releases its claim of lien for labor, services, or materials furnished to Six Mile Creek Investment Group, on the job of Trailmark PH 13, for the following described property:

Trailmark PH 13

The undersigned lienor acknowledges previous receipt of \$4,957,894.88 and is executing this waiver and release in exchange for a check or checks in the additional amount of \$667,002.62, this partial release of claim of lien expressly and totally is conditioned on receipt of the check or checks and the collection of the funds in the amount of \$667,002.62.

There remains unpaid \$2,672,250.86

Dated: November 25, 20 24

Signed and sealed in the presence of:

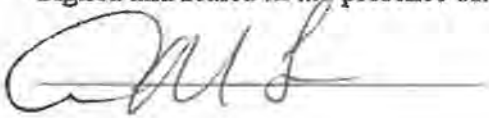

Witness



Lienor

STATE OF FLORIDA
COUNTY OF Duval

I HEREBY CERTIFY that on this day, November 25, 2024, before me, an officer duly authorized in the State aforesaid and in the County aforesaid to take acknowledgments, personally appeared Charles D. Freshwater, as President of Jax Utilities Management, Inc. a Florida corporation, on behalf of the corporation, and she/he acknowledged before me that she/he executed the same and did so by order of the Board of Directors of the Corporation.

He/She is personally known to me produced N/A as identification



Notary Public

REQUISITION NO. 93
(2023 Acquisition and Construction Account)

SIX MILE CREEK COMMUNITY DEVELOPMENT DISTRICT
(ST. JOHNS COUNTY, FLORIDA)
\$10,515,000
Capital Improvement Revenue Bonds
Series 2023 (2023 Project Area)

The undersigned, an Authorized Officer of Six Mile Creek Community Development District (the "District") hereby submits the following requisition for disbursement under and pursuant to the terms of the Master Trust Indenture from the District to U.S. Bank Trust Company, National Association, as successor trustee (the "Trustee"), dated as of July 1, 2007 (the "Master Indenture"), as amended and supplemented by the Eleventh Supplemental Trust Indenture between the District and Trustee, dated as of June 1, 2023 (the Master Indenture as amended and supplemented is hereinafter referred to as the "Indenture") (all capitalized terms used herein shall have the meaning ascribed to such term in the Indenture):

- (A) Requisition Number: 93
- (B) Name of Payee: **Wire Transfer Instructions: Jax Utilities Management, Inc. Truist Bank 214 North Tryon St. Charlotte, NC 28202 ABA: Beneficiary: JAX UTILITIES MANAGEMENT INC (Business Account Title) Account #: Routing #:**
- (C) Amount Payable: **\$ 56,624.75**
- (D) Purpose for which paid or incurred (refer also to specific contract if amount is due and payable pursuant to a contract involving progress payments, or, state Costs of Issuance, if applicable): **Trailmark East Parcel Phase 3, Application No. 19 (November 2024)**
- (E) Fund or Account and subaccount, if any, from which disbursement is to be made:

\$ 56,624.75 - Assessment Area 2 - Phase 3C Subaccount
\$ _____ - Assessment Area 3 - Phase 3 Subaccount

The undersigned hereby certifies that obligations in the stated amount set forth above have been incurred by the District, that each disbursement set forth above is a proper charge against the 2023 Acquisition and Construction Account and the subaccount, if any, referenced above, that each disbursement set forth above was incurred in connection with the acquisition and construction

of the 2023 Project and each represents a Cost of the 2023 Project, and has not previously been paid.

The undersigned hereby further certifies that there has not been filed with or served upon the District notice of any lien, right to lien, or attachment upon, or claim affecting the right to receive payment of, any of the moneys payable to the Payee set forth above, which has not been released or will not be released simultaneously with the payment hereof.

The undersigned hereby further certifies that such requisition contains no item representing payment on account of any retained percentage which the District is at the date of such certificate entitled to retain.

If this requisition is for a disbursement from other than the Costs of Issuance Account or for payment of capitalized interest, there shall be attached a resolution of the Governing Body of the District approving this requisition or approving the specific contract with respect to which disbursements pursuant to this requirement are due and payable.

Attached hereto are originals of the invoice(s) from the vendor of the property acquired or the services rendered with respect to which disbursement is hereby requested.

**SIX MILE CREEK COMMUNITY
DEVELOPMENT DISTRICT**

By: _____
Gregg F. Kern
Chairperson, Board of Supervisors

**CONSULTING ENGINEER'S APPROVAL FOR NON-COST OF ISSUANCE AND
CAPITALIZED INTEREST REQUESTS ONLY**

If this requisition is for a disbursement from other than Capitalized Interest or Costs of Issuance, the undersigned Consulting Engineer hereby certifies that this disbursement is for a Cost of the 2023 Project and is consistent with: (i) the applicable acquisition or construction contract; (ii) the plans and specifications for the portion of the 2023 Project with respect to which such disbursement is being made; and, (iii) the report of the Consulting Engineer attached as an Exhibit to the Eleventh Supplemental Trust Indenture, as such report shall have been amended or modified on the date hereof.

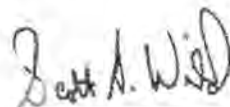
By:  _____
Consulting Engineer

APPLICATION AND CERTIFICATION FOR PAYMENT

AIA DOCUMENT G702



FROM (CONTRACTOR):
Jax Utilities Management, Inc
 5465 Verna Boulevard
 Jacksonville, FL 32205

TO (OWNER):
Six Mile Creek CDD
 c/o England-Thims & Miller, Inc.
 14775 Old St. Augustine Road
 Jacksonville, FL 32258

APPLICATION NO: 19

Reviewed and Striping is not done. CO11?
 Pong L. 12-4-24

PERIOD TO: November 25, 2024

PROJECT: **Trailmark East Parcel PH 3**

CONTRACT FOR:
 Underground Infrastructure & Site Development

CONTRACTORS APPLICATION FOR PAYMENT

CHANGE ORDER SUMMARY		ADDITIONS	DEDUCTIONS
Change Orders approved in previous months by Owner		TOTAL	0.00
Approved this Month			
Number	Date Approved		
1	04/20/23	397,600.00	
2	4/24/2023		(142,000.00)
3	11/2/2023		(1,357,235.99)
4	4/3/2024	567,979.00	
5	4/4/2024		(2,190,450.00)
6	6/13/2024		(21,145.00)
7	8/6/2024 (Rain Days)		
8	8/25/2024	16,940.00	
9	9/10/2024 (Rain Days)		
10	9-20-24 (Rain Days)		
11	11/20/2024	8,460.00	
TOTALS		990,979.00	(3,655,821.46)

Net change by Change Orders (2,664,842.46)
 The undersigned Contractor certifies that to the best of the Contractor's knowledge, information and belief the Work covered by this Application for Payment has been completed in accordance with the Contract Documents, that all amounts have been paid for by the Contractor for Work for which previous Certificates for Payment were issued and payments received from the Owner, and the current payment shown herein is now due.

Application is made for payment, as shown below, in connection with the Contract. Continuation sheet, AIA Document G703, is attached.

1. ORIGINAL CONTRACT SUM	\$11,673,640.00
2. Net Change by Change Orders	-\$2,664,842.46
3. CONTRACT SUM TO DATE (LINE 1 +, - 2)	\$9,008,797.54
4. TOTAL COMPLETED AND STORED TO DATE	\$8,638,597.54
5. RETAINAGE	
a. 5% % (Column D+E on G703)	
Total retainage (Line 5a, or Total in Column J of G703)	\$431,929.88
6. TOTAL EARNED LESS RETAINAGE (Line 4 less Line 5 Total)	\$8,206,667.66
7. LESS PREVIOUS CERTIFICATES FOR PAYMENT (Line 6 from prior Certificate)	\$8,150,042.91
8. CURRENT PAYMENT DUE	\$56,624.75
9. BALANCE TO FINISH, PLUS RETAINAGE (Line 3 less Line 6)	\$802,129.88

State of: Florida County of: Duval
 Subscribed and sworn before me this 25th day of November 2024
 Notary Public: [Signature]
 My Commission expires: August 17, 2026

AMOUNT CERTIFIED: \$56,624.75
 ENGINEER: England, Thims & Miller, Inc.
 BY: [Signature] DATE: 12/9/2024

This Certificate is not negotiable. The AMOUNT CERTIFIED is payable only to the Contractor named herein. Issuance, payment and acceptance of payments are without prejudice to any rights of the Owner or Contractor under this Contract

CONTRACTOR: Jax Utilities Management, Inc

By: [Signature] Date: 11/25/2024

ENGINEERS CERTIFICATE FOR PAYMENT

In accordance with the Contract Documents, based on on-site observations and the data comprising the above application, the Engineer certifies to the Owner that to the best of the Engineers knowledge, information and belief the Work has progressed as indicated, the quality of the Work is in accordance with the Contract Documents, and the Contractor is entitled to payment of the AMOUNT CERTIFIED.

REVENUE REPORT

Project Number: 202247
 Project Name: Trailmark EP 3
 Owner Name: ET&M
 Contract Number: 21-350
 For Month Ending: 11/25/2024

\$367.00
 \$250.00

\$217.00

Period Ending: 11/25/24
 Variance \$0.00
 Projected Final \$9,008,797.54
 Billings To Date \$8,638,597.54
 Remaining Billings \$370,200.00

Bid Items	Original Contract L & E				Previous Quantity	Current		Materials Amount	To Date		Remaining		Projected Final		% Complete	Projection vs. Original	
	Qty	UM	Unit Price	Total L & E Total		Quantity	Amount		Quantity	Amount	Quantity	Amount	Quantity	Amount		Quantity	Amount
MOBILIZATION & SITE PREPARATION																	
Mobilization	1.00	LS	74,000.00	\$ 74,000.00	1.00	\$			1.00	\$ 74,000.00	-	\$	1.00	\$ 74,000.00	100%	0.00	\$ -
Survey	1.00	LS	56,500.00	\$ 56,500.00	0.95	0.05	\$ 2,825.00		1.00	\$ 56,500.00	-	\$	1.00	\$ 56,500.00	100%	0.00	\$ -
MOT	1.00	LS	3,000.00	\$ 3,000.00	0.95	0.05	\$ 150.00		1.00	\$ 3,000.00	-	\$	1.00	\$ 3,000.00	100%	0.00	\$ -
Demolition	1.00	LS	6,700.00	\$ 6,700.00	1.00	\$			1.00	\$ 6,700.00	-	\$	1.00	\$ 6,700.00	100%	0.00	\$ -
Total				\$ 140,200.00			\$ 2,975.00			\$ 140,200.00		\$		\$ 140,200.00	100.00%		\$
CLEARING & GRUBBING																	
Clearing	44.00	CY	5,900.00	\$ 303,600.00	44.00	\$			44.00	\$ 303,600.00	-	\$	44.00	\$ 303,600.00	100%	0.00	\$ -
Grubbing	44.00	CY	3,700.00	\$ 162,800.00	44.00	\$			44.00	\$ 162,800.00	-	\$	44.00	\$ 162,800.00	100%	0.00	\$ -
Total				\$ 466,400.00			\$			\$ 466,400.00		\$		\$ 466,400.00	100.00%		\$
UNSUITABLE MATERIAL R & R																	
Remove & Replace Unsuitable Mat.	4,000.00	CY	27.00	\$ 108,000.00	4,000.00	\$			4,000.00	\$ 108,000.00	-	\$	4,000.00	\$ 108,000.00	100%	0.00	\$ -
Total				\$ 108,000.00			\$			\$ 108,000.00		\$		\$ 108,000.00	100.00%		\$
STORMWATER MANAGEMENT																	
Pond Excavation	48,400.00	CY	4.50	\$ 217,800.00	48,400.00	\$			48,400.00	\$ 217,800.00	-	\$	48,400.00	\$ 217,800.00	100%	0.00	\$ -
Geotexturing	1.00	LS	48,000.00	\$ 48,000.00	1.00	\$			1.00	\$ 48,000.00	-	\$	1.00	\$ 48,000.00	100%	0.00	\$ -
Total				\$ 265,800.00			\$			\$ 265,800.00		\$		\$ 265,800.00	100.00%		\$
EARTHWORK																	
Roadway Excavation Cut/ Balance	17,000.00	SY	8.00	\$ 136,000.00	17,000.00	\$			17,000.00	\$ 136,000.00	-	\$	17,000.00	\$ 136,000.00	100%	0.00	\$ -
R/W Dress Up	11,950.00	LF	2.00	\$ 23,900.00	11,950.00	\$			11,950.00	\$ 23,900.00	-	\$	11,950.00	\$ 23,900.00	100%	0.00	\$ -
Max. Site & Swale Grading	1.00	LS	18,000.00	\$ 18,000.00	1.00	\$			1.00	\$ 18,000.00	-	\$	1.00	\$ 18,000.00	100%	0.00	\$ -
Lot Fill from On Site	48,400.00	CY	1.25	\$ 60,500.00	48,400.00	\$			48,400.00	\$ 60,500.00	-	\$	48,400.00	\$ 60,500.00	100%	0.00	\$ -
Lot Fill Import	160,000.00	CY	24.00	\$ 3,840,000.00	160,000.00	\$			160,000.00	\$ 3,840,000.00	-	\$	160,000.00	\$ 3,840,000.00	100%	0.00	\$ -
Lot Grading & Dress Up	1.00	LS	46,000.00	\$ 46,000.00	1.00	\$			1.00	\$ 46,000.00	-	\$	1.00	\$ 46,000.00	100%	0.00	\$ -
Total				\$ 4,134,400.00			\$			\$ 4,134,400.00		\$		\$ 4,134,400.00	100.00%		\$
ROADWAY CONSTRUCTION																	
Miami Curb (incl. backfill)	11,950.00	LF	16.00	\$ 191,200.00	11,950.00	\$			11,950.00	\$ 191,200.00	-	\$	11,950.00	\$ 191,200.00	100%	0.00	\$ -
12" Roadway Base (Crychrete)	14,300.00	SY	19.50	\$ 278,850.00	14,300.00	\$			14,300.00	\$ 278,850.00	-	\$	14,300.00	\$ 278,850.00	100%	0.00	\$ -
12" Stabilized Subgrade	16,950.00	SY	9.50	\$ 161,025.00	16,950.00	\$			16,950.00	\$ 161,025.00	-	\$	16,950.00	\$ 161,025.00	100%	0.00	\$ -
Asphalt 1" (Est. lift)	13,300.00	SY	17.50	\$ 232,750.00	13,300.00	\$			13,300.00	\$ 232,750.00	-	\$	13,300.00	\$ 232,750.00	100%	0.00	\$ -
Asphalt 1" (Est. lift)	14,300.00	SY	1.00	\$ 14,300.00	14,300.00	\$			14,300.00	\$ 14,300.00	-	\$	14,300.00	\$ 14,300.00	100%	0.00	\$ -
Driveway	1.00	LS	8,500.00	\$ 8,500.00		1.00	\$ 8,500.00		1.00	\$ 8,500.00	-	\$	1.00	\$ 8,500.00	100%	0.00	\$ -
Sidewalks (inc. backfill)	367.00	SY	75.00	\$ 27,525.00	217.00	\$			217.00	\$ 16,725.00	150.00	\$ 11,250.00	367.00	\$ 27,525.00	99%	0.00	\$ -
Handicap Ramps	13.00	EA	2,300.00	\$ 29,900.00	12.00	\$			12.00	\$ 27,600.00	1.00	\$ 2,300.00	13.00	\$ 29,900.00	92%	0.00	\$ -
Total				\$ 495,750.00			\$ 8,500.00			\$ 495,750.00		\$ 11,250.00		\$ 495,750.00	99.80%		\$
STORM DRAINAGE SYSTEM																	
15" RCP	920.00	LF	\$ 47.69	\$ 43,874.80	920.00	\$	\$ 20,525.20		920.00	\$ 64,400.00	-	\$	920.00	\$ 64,400.00	100%	0.00	\$ -
18" RCP	482.00	LF	\$ 78.46	\$ 37,817.72	482.00	\$	\$ 13,274.28		482.00	\$ 51,092.00	-	\$	482.00	\$ 51,092.00	100%	0.00	\$ -
24" RCP	935.00	LF	\$ 101.79	\$ 95,179.65	935.00	\$	\$ 40,404.35		935.00	\$ 135,575.00	-	\$	935.00	\$ 135,575.00	100%	0.00	\$ -
30" RCP	858.00	LF	\$ 126.86	\$ 108,845.88	858.00	\$	\$ 59,322.12		858.00	\$ 168,168.00	-	\$	858.00	\$ 168,168.00	100%	0.00	\$ -
36" RCP	972.00	LF	\$ 190.03	\$ 184,709.16	972.00	\$	\$ 74,814.84		972.00	\$ 259,524.00	-	\$	972.00	\$ 259,524.00	100%	0.00	\$ -
42" RCP	373.00	LF	\$ 282.12	\$ 105,230.76	373.00	\$	\$ 37,255.24		373.00	\$ 142,486.00	-	\$	373.00	\$ 142,486.00	100%	0.00	\$ -
48" RCP	541.00	LF	\$ 311.96	\$ 168,770.36	541.00	\$	\$ 71,974.84		541.00	\$ 240,745.00	-	\$	541.00	\$ 240,745.00	100%	0.00	\$ -
29x65 ERCP	388.00	LF	\$ 208.42	\$ 80,866.96	388.00	\$	\$ 78,713.04		388.00	\$ 159,080.00	-	\$	388.00	\$ 159,080.00	100%	0.00	\$ -
Curb Inlets	21.00	EA	\$ 3,176.09	\$ 66,697.89	21.00	\$	\$ 85,972.11		21.00	\$ 152,670.00	-	\$	21.00	\$ 152,670.00	100%	0.00	\$ -
Double Curb Inlets	12.00	EA	\$ 6,607.23	\$ 79,286.76	12.00	\$	\$ 55,313.24		12.00	\$ 174,800.00	-	\$	12.00	\$ 174,800.00	100%	0.00	\$ -
Manholes	14.00	EA	\$ 6,015.45	\$ 84,216.30	14.00	\$	\$ 53,783.70		14.00	\$ 140,090.00	-	\$	14.00	\$ 140,090.00	100%	0.00	\$ -
15" MES	5.00	EA	\$ 786.44	\$ 3,932.20	5.00	\$	\$ 2,667.80		5.00	\$ 6,600.00	-	\$	5.00	\$ 6,600.00	100%	0.00	\$ -
18" MES	1.00	EA	\$ 786.44	\$ 786.44	1.00	\$	\$ 533.56		1.00	\$ 1,120.00	-	\$	1.00	\$ 1,320.00	100%	0.00	\$ -
30" MES	1.00	EA	\$ 1,606.02	\$ 1,606.02	1.00	\$	\$ 1,293.98		1.00	\$ 2,900.00	-	\$	1.00	\$ 2,900.00	100%	0.00	\$ -
36" MES	2.00	EA	\$ 2,047.12	\$ 4,094.24	2.00	\$	\$ 3,305.76		2.00	\$ 7,400.00	-	\$	2.00	\$ 7,400.00	100%	0.00	\$ -

REVENUE REPORT

Project Number: 202247
 Project Name: Trailmark EP 3
 Owner Name: ET&M
 Contract Number: 23-350
 For Month Ending: 11/25/2024

\$367.00
 -\$150.00
 \$217.00

Period Ending: 11/25/24
 Variance \$0.00
 Projected Final \$8,008,797.54
 Billings To Date \$8,638,597.54
 Remaining Billings \$170,200.00

Bid Items	Original Contract L & E				Previous Quantity	Current		Materials Amount	To Date		Remaining		Projected Final		NC Complete	Projection vs. Original Variance at Completion	
	Qty	UM	Unit Price	Total L & E Only		Quantity	Amount		Quantity	Amount	Quantity	Amount	Quantity	Amount		Quantity	Amount
42" MES	1.00	EA	\$ 24,858.10	\$ 24,858.10	1.00	\$ -	\$ 1,341.90	1.00	\$ 26,200.00	\$ -	\$ -	1.00	\$ 26,200.00	100%	0.00	\$ -	
48" MES	1.00	EA	\$ 28,850.69	\$ 28,850.69	1.00	\$ -	\$ 1,649.31	1.00	\$ 30,500.00	\$ -	\$ -	1.00	\$ 30,500.00	100%	0.00	\$ -	
29x45 MES	1.00	EA	\$ 25,000.00	\$ 25,000.00	1.00	\$ -	\$ -	1.00	\$ 25,000.00	\$ -	\$ -	1.00	\$ 25,000.00	100%	0.00	\$ -	
Under-drain Stubs	1,800.00	LF	\$ 40.00	\$ 72,000.00	1,800.00	\$ -	\$ -	1,800.00	\$ 72,000.00	\$ -	\$ -	1,800.00	\$ 72,000.00	100%	0.00	\$ -	
Adjustments	60.00	EA	\$ 850.00	\$ 51,000.00	60.00	\$ -	\$ -	60.00	\$ 51,000.00	\$ -	\$ -	60.00	\$ 51,000.00	100%	0.00	\$ -	
TV Storm Drain	5,738.00	LF	\$ 19.00	\$ 109,022.00	5,738.00	\$ -	\$ -	5,738.00	\$ 109,022.00	\$ -	\$ -	5,738.00	\$ 109,022.00	100%	0.00	\$ -	
Type C Inlet	10.00	EA	\$ 3,024.66	\$ 30,246.60	10.00	\$ -	\$ 21,493.40	10.00	\$ 63,700.00	\$ -	\$ -	10.00	\$ 63,700.00	100%	0.00	\$ -	
Type E Inlet	3.00	EA	\$ 4,558.70	\$ 13,676.10	3.00	\$ -	\$ 14,973.90	3.00	\$ 28,650.00	\$ -	\$ -	3.00	\$ 28,650.00	100%	0.00	\$ -	
Remove & Replace Unsuitable Matr.	1,250.00	CY	\$ 28.00	\$ 35,000.00	1,250.00	\$ -	\$ -	1,250.00	\$ 35,000.00	\$ -	\$ -	1,250.00	\$ 35,000.00	100%	0.00	\$ -	
12" PVC	131.00	LF	\$ 78.00	\$ 10,218.00	131.00	\$ -	\$ -	131.00	\$ 10,218.00	\$ -	\$ -	131.00	\$ 10,218.00	100%	0.00	\$ -	
15" PVC	138.00	EA	\$ 99.00	\$ 13,662.00	138.00	\$ -	\$ -	138.00	\$ 13,662.00	\$ -	\$ -	138.00	\$ 13,662.00	100%	0.00	\$ -	
Total				\$ 1,479,482.63		\$ -	\$ 481,869.17		\$ 1,181,713.00	\$ 38.00	\$ -		\$ 1,181,713.00	100.00%		\$ -	
ROADWAY UNDERDRAIN																	
Roadway Underdrain	3,000.00	LF	\$ 33.88	\$ 101,640.00		\$ -	\$ 18,360.00		\$ 18,360.00	3,000.00	\$ 101,640.00	3,000.00	\$ 110,000.00	15%	0.00	\$ -	
Total				\$ 101,640.00		\$ -	\$ 18,360.00		\$ 18,360.00		\$ 101,640.00		\$ 110,000.00	43%		\$ -	
PAVING & DRAINAGE AS-BUILTS																	
Paving & Drainage As-Builts	1.00	LS	\$ 44,000.00	\$ 44,000.00	0.60	\$ 0.16	\$ 4,400.00		\$ 30,900.00	0.30	\$ 13,200.00	1.00	\$ 44,000.00	70%	0.00	\$ -	
Total				\$ 44,000.00		\$ 0.16	\$ 4,400.00		\$ 30,900.00		\$ 13,200.00		\$ 44,000.00	70.00%		\$ -	
SJCUD WATER DISTRIBUTION SYSTEM																	
8" Watermain (inc. fittings-T's, bends)	5,430.00	LF	\$ 7.29	\$ 311,084.70	5,430.00	\$ -	\$ 183,945.30	5,430.00	\$ 494,130.00	\$ -	\$ -	5,430.00	\$ 494,130.00	100%	0.00	\$ -	
4" Watermain (inc. fittings-T's, bends)	300.00	LF	\$ 41.00	\$ 12,300.00	300.00	\$ -	\$ 4,800.00	300.00	\$ 12,300.00	\$ -	\$ -	300.00	\$ 12,300.00	100%	0.00	\$ -	
2" Watermain (inc. fittings-T's, bends)	340.00	LF	\$ 31.26	\$ 10,628.40	340.00	\$ -	\$ 3,311.60	340.00	\$ 7,140.00	\$ -	\$ -	340.00	\$ 7,140.00	100%	0.00	\$ -	
Tie-Ins	3.00	EA	\$ 7,700.00	\$ 23,100.00		1.00	\$ 7,700.00	1.00	\$ 7,700.00	2.00	\$ 15,400.00	3.00	\$ 23,100.00	33%	0.00	\$ -	
10" Road Crossings	5.00	EA	\$ 9,302.50	\$ 46,512.50	5.00	\$ -	\$ 7,997.50	5.00	\$ 54,500.00	\$ -	\$ -	5.00	\$ 54,500.00	100%	0.00	\$ -	
Fire Hydrants w/ Gate Valve	12.00	EA	\$ 2,992.62	\$ 35,911.44	12.00	\$ -	\$ 45,688.56	12.00	\$ 81,600.00	\$ -	\$ -	12.00	\$ 81,600.00	100%	0.00	\$ -	
Flushing Hydrants	2.00	EA	\$ 1,009.50	\$ 2,019.00	2.00	\$ -	\$ 5,981.00	2.00	\$ 8,000.00	\$ -	\$ -	2.00	\$ 8,000.00	100%	0.00	\$ -	
Services	182.00	EA	\$ 434.84	\$ 79,140.88	182.00	\$ -	\$ 64,679.17	182.00	\$ 143,780.00	\$ -	\$ -	182.00	\$ 143,780.00	100%	0.00	\$ -	
Test & Chlorinate	6,070.00	LF	\$ 1.00	\$ 6,070.00		6,070.00	\$ 6,070.00	6,070.00	\$ 6,070.00	\$ -	\$ -	6,070.00	\$ 6,070.00	100%	0.00	\$ -	
Adjustments	1.00	LF	\$ 12,900.00	\$ 12,900.00		1.00	\$ 12,900.00	1.00	\$ 12,900.00	\$ -	\$ -	1.00	\$ 12,900.00	100%	0.00	\$ -	
Total				\$ 442,898.92		\$ 26,671.60	\$ 110,453.69		\$ 842,830.70	\$ 11,400.00	\$ -		\$ 842,830.70	88.15%		\$ -	
SJCUD SANITARY SEWER SYSTEM																	
8" Sewer	5,532.00	LF	\$ 79.74	\$ 441,121.68	5,532.00	\$ -	\$ 106,546.11	5,532.00	\$ 547,668.00	\$ -	\$ -	5,532.00	\$ 547,668.00	100%	0.00	\$ -	
Manholes	27.00	EA	\$ 6,161.17	\$ 166,351.59	27.00	\$ -	\$ 160,348.41	27.00	\$ 326,700.00	\$ -	\$ -	27.00	\$ 326,700.00	100%	0.00	\$ -	
Services	178.00	EA	\$ 487.14	\$ 86,710.92	178.00	\$ -	\$ 65,039.08	178.00	\$ 155,750.00	\$ -	\$ -	178.00	\$ 155,750.00	100%	0.00	\$ -	
Dewater	1.00	LS	\$ 162,000.00	\$ 162,000.00	1.00	\$ -	\$ -	1.00	\$ 162,000.00	\$ -	\$ -	1.00	\$ 162,000.00	100%	0.00	\$ -	
Adjustments	1.00	LS	\$ 30,589.80	\$ 30,589.80	1.00	\$ -	\$ 410.70	1.00	\$ 41,000.00	\$ -	\$ -	1.00	\$ 41,000.00	100%	0.00	\$ -	
TV Testing	5,880.00	LF	\$ 12.00	\$ 70,560.00	5,880.00	\$ -	\$ -	5,880.00	\$ 70,560.00	\$ -	\$ -	5,880.00	\$ 70,560.00	100%	0.00	\$ -	
Connect to Existing	3.00	EA	\$ 8,900.00	\$ 26,700.00	3.00	\$ -	\$ -	3.00	\$ 26,700.00	\$ -	\$ -	3.00	\$ 26,700.00	100%	0.00	\$ -	
Benchdown & Backfill	1.00	LS	\$ 36,000.00	\$ 36,000.00	1.00	\$ -	\$ -	1.00	\$ 36,000.00	\$ -	\$ -	1.00	\$ 36,000.00	100%	0.00	\$ -	
Remove & Replace Unsuitable Matr.	4,900.00	CY	\$ 28.00	\$ 137,200.00	4,900.00	\$ -	\$ -	4,900.00	\$ 137,200.00	\$ -	\$ -	4,900.00	\$ 137,200.00	100%	0.00	\$ -	
Line Existing Manholes	3.00	EA	\$ 9,000.00	\$ 27,000.00	3.00	\$ -	\$ -	3.00	\$ 27,000.00	\$ -	\$ -	3.00	\$ 27,000.00	100%	0.00	\$ -	
Total				\$ 1,184,733.94		\$ -	\$ 306,344.82		\$ 1,520,176.80	\$ 38.00	\$ -		\$ 1,520,176.80	100.00%		\$ -	
WATER & SEWER AS-BUILTS																	
Water & Sewer As-Builts	1.00	LS	\$ 49,000.00	\$ 49,000.00	0.50	\$ 0.50	\$ 4,900.00		\$ 34,300.00	0.30	\$ 14,700.00	1.00	\$ 49,000.00	70%	0.00	\$ -	
Total				\$ 49,000.00		\$ 0.50	\$ 4,900.00		\$ 34,300.00		\$ 14,700.00		\$ 49,000.00	70.00%		\$ -	
IRRIGATION-ELEC-TELE-CATV SLEEVES																	
1" Sleeves	4,000.00	LF	\$ 13.00	\$ 52,000.00	4,000.00	\$ -	\$ -	4,000.00	\$ 52,000.00	\$ -	\$ -	4,000.00	\$ 52,000.00	100%	0.00	\$ -	
3" Sleeves	3,500.00	LF	\$ 15.00	\$ 52,500.00		\$ -	\$ -		\$ -	3,500.00	\$ 52,500.00	3,500.00	\$ 52,500.00	0%	0.00	\$ -	
4" Sleeves	4,500.00	LF	\$ 17.00	\$ 76,500.00	1,690.00	\$ -	\$ -	1,690.00	\$ 28,730.00	2,810.00	\$ 47,770.00	4,500.00	\$ 76,500.00	38%	0.00	\$ -	
6" Sleeves	3,000.00	LF	\$ 19.00	\$ 57,000.00	1,040.00	\$ -	\$ -	1,040.00	\$ 19,740.00	1,960.00	\$ 37,240.00	3,000.00	\$ 57,000.00	35%	0.00	\$ -	
Total				\$ 134,000.00		\$ -	\$ -		\$ 100,470.00		\$ 87,710.00		\$ 134,000.00	42.32%		\$ -	

REVENUE REPORT

Project Number: 202247
 Project Name: Trailmark EP 3
 Owner Name: ET&M
 Contract Number: 21-350
 For Month Ending: 11/25/2024

\$367.00
 -\$150.00

\$217.00

Period Ending: 11/25/24
 Variance \$0.00
 Projected Final \$9,008,797.54
 Billings To Date \$8,638,597.54
 Remaining Billings \$370,200.00

Bid Items	Original Contract L & E				Previous Quantity	Current		Material Amount	To Date		Remaining		Projected Final		% Complete	Projection vs. Original	
	Qty	UM	Unit Price	Total L & E Only		Quantity	Amount		Quantity	Amount	Quantity	Amount	Quantity	Amount		Quantity	Amount
FPL ELECTRIC ALLOWANCE																	
FPL Bid Once	1.00	LS	175,000.00	\$ 175,000.00	1.00	\$ -			1.00	\$ 175,000.00	- \$	-	1.00	\$ 175,000.00	100%	0.00	\$ -
Total				\$ 175,000.00		\$ -			\$ 175,000.00	\$ 0.00			\$ 175,000.00	100.00%		\$ -	
SEEDING - SOO																	
Seeding Lots	157,000.00	SY	0.50	\$ 78,500.00	157,000.00	\$ -			157,000.00	\$ 78,500.00	- \$	-	157,000.00	\$ 78,500.00	100%	0.00	\$ -
Seeding R/W	19,000.00	SY	0.50	\$ 9,500.00	19,000.00	\$ -			19,000.00	\$ 9,500.00	- \$	-	19,000.00	\$ 9,500.00	100%	0.00	\$ -
Sod Ponds	6,700.00	SY	4.00	\$ 26,800.00	6,700.00	\$ -			6,700.00	\$ 26,800.00	- \$	-	6,700.00	\$ 26,800.00	100%	0.00	\$ -
Sod Back of Lot Slope & Swales	14,200.00	SY	4.00	\$ 56,800.00	14,200.00	\$ -			14,200.00	\$ 56,800.00	- \$	-	14,200.00	\$ 56,800.00	100%	0.00	\$ -
Sod BOC & EDP	2,500.00	SY	4.00	\$ 10,000.00	1,950.00	\$ 5,800.00	\$ 2,200.00		2,500.00	\$ 10,000.00	- \$	-	2,500.00	\$ 10,000.00	100%	0.00	\$ -
Total				\$ 181,600.00		\$ 5,800.00	\$ 2,200.00		\$ 181,600.00	\$ 0.00			\$ 181,600.00	100.00%		\$ -	
SEDIMENT & EROSION CONTROL																	
NPDES	1.00	LS	18,000.00	\$ 18,000.00	0.95	\$ 0.00	\$ 900.00		1.00	\$ 18,000.00	- \$	-	1.00	\$ 18,000.00	100%	0.00	\$ -
Silt Fence	7,900.00	LF	4.00	\$ 31,600.00	7,900.00	\$ -			7,900.00	\$ 31,600.00	- \$	-	7,900.00	\$ 31,600.00	100%	0.00	\$ -
Construction Entrance	1.00	EA	6,000.00	\$ 6,000.00	1.00	\$ -			1.00	\$ 6,000.00	- \$	-	1.00	\$ 6,000.00	100%	0.00	\$ -
Inlet Protection	42.00	EA	440.00	\$ 18,480.00	42.00	\$ -			42.00	\$ 18,480.00	- \$	-	42.00	\$ 18,480.00	100%	0.00	\$ -
Turbidity Control	1.00	LS	25,000.00	\$ 25,000.00	1.00	\$ -			1.00	\$ 25,000.00	- \$	-	1.00	\$ 25,000.00	100%	0.00	\$ -
Total				\$ 88,080.00		\$ -	\$ 900.00		\$ 88,080.00	\$ 0.00			\$ 88,080.00	100.00%		\$ -	
SWPPP																	
SWPPP	1.00	LS	12,000.00	\$ 12,000.00	0.96	\$ 0.00	\$ 600.00		1.00	\$ 12,000.00	- \$	-	1.00	\$ 12,000.00	100%	0.00	\$ -
Total				\$ 12,000.00		\$ -	\$ 600.00		\$ 12,000.00	\$ 0.00			\$ 12,000.00	100.00%		\$ -	
BONDS																	
Payment & Performance Bond	1.00	LS	183,000.00	\$ 183,000.00	1.00	\$ -			1.00	\$ 183,000.00	- \$	-	1.00	\$ 183,000.00	100%	0.00	\$ -
Contractor Warranty	1.00	LS	28,000.00	\$ 28,000.00		\$ -				\$ -	1.00	\$ 28,000.00	1.00	\$ 28,000.00	0%	0.00	\$ -
Total				\$ 211,000.00		\$ -			\$ 183,000.00	\$ 28,000.00			\$ 211,000.00	0.00%		\$ -	
CHANGE ORDERS																	
Change Order	Original				To Date	Current		To Date	Remaining		Projected Final		% Complete	Projection vs. Original			
	Qty	UM	Unit Price	Total Amount		Quantity	Amount		Quantity	Amount	Quantity	Amount		Quantity	Amount		
Change Order 1																	
Clear Haul Road	1.00	LS	6,900.00	\$ 6,900.00	1.00	\$ -			1.00	\$ 6,900.00	- \$	-	1.00	\$ 6,900.00	100%	0.00	\$ -
Strip Haul Road	1.00	LS	3,700.00	\$ 3,700.00	1.00	\$ -			1.00	\$ 3,700.00	- \$	-	1.00	\$ 3,700.00	100%	0.00	\$ -
Haul to PH-10	40,000.00	CY	7.80	\$ 312,000.00	40,000.00	\$ -			40,000.00	\$ 312,000.00	- \$	-	40,000.00	\$ 312,000.00	100%	0.00	\$ -
Maintain Haul Road	1.00	LS	75,000.00	\$ 75,000.00	1.00	\$ -			1.00	\$ 75,000.00	- \$	-	1.00	\$ 75,000.00	100%	0.00	\$ -
Change Order 2																	
ADS Credit	1.00	LS	(142,000.00)	\$ (142,000.00)	1.00	\$ -			1.00	\$ (142,000.00)	- \$	-	1.00	\$ (142,000.00)	100%	0.00	\$ -
Change Order 3																	
Ferguson Materials	1.00	LS	(776,879.20)	\$ (776,879.20)	1.00	\$ -			1.00	\$ (776,879.20)	- \$	-	1.00	\$ (776,879.20)	100%	0.00	\$ -
Tax	1.00	LS	(50,497.15)	\$ (50,497.15)	1.00	\$ -			1.00	\$ (50,497.15)	- \$	-	1.00	\$ (50,497.15)	100%	0.00	\$ -
American Precast	1.00	LS	(416,569.00)	\$ (416,569.00)	1.00	\$ -			1.00	\$ (416,569.00)	- \$	-	1.00	\$ (416,569.00)	100%	0.00	\$ -
Tax	1.00	LS	(27,076.99)	\$ (27,076.99)	1.00	\$ -			1.00	\$ (27,076.99)	- \$	-	1.00	\$ (27,076.99)	100%	0.00	\$ -
County Materials	1.00	LS	(76,248.00)	\$ (76,248.00)	1.00	\$ -			1.00	\$ (76,248.00)	- \$	-	1.00	\$ (76,248.00)	100%	0.00	\$ -
Tax	1.00	LS	(4,956.12)	\$ (4,956.12)	1.00	\$ -			1.00	\$ (4,956.12)	- \$	-	1.00	\$ (4,956.12)	100%	0.00	\$ -
Change Order 4 Haul Rd.																	
Erosion Control NPDES	1.00	LS	15,000.00	\$ 15,000.00	1.00	\$ -			1.00	\$ 15,000.00	- \$	-	1.00	\$ 15,000.00	100%	0.00	\$ -
Silt Fence	7,000.00	LF	4.00	\$ 28,000.00	7,000.00	\$ -			7,000.00	\$ 28,000.00	- \$	-	7,000.00	\$ 28,000.00	100%	0.00	\$ -
Staked Turbidity Barrier	3,052.00	LF	9.50	\$ 28,994.00	3,052.00	\$ -			3,052.00	\$ 28,994.00	- \$	-	3,052.00	\$ 28,994.00	100%	0.00	\$ -
Clearing and Grubbing	3.60	AC	9,900.00	\$ 35,640.00	3.60	\$ -			3.60	\$ 35,640.00	- \$	-	3.60	\$ 35,640.00	100%	0.00	\$ -
Stripping & Demucking	6,000.00	CY	8.00	\$ 48,000.00	6,000.00	\$ -			6,000.00	\$ 48,000.00	- \$	-	6,000.00	\$ 48,000.00	100%	0.00	\$ -
Fill Roadways	10,655.00	CY	7.80	\$ 83,109.00	10,655.00	\$ -			10,655.00	\$ 83,109.00	- \$	-	10,655.00	\$ 83,109.00	100%	0.00	\$ -
Grading	1.00	LS	3,900.00	\$ 3,900.00	1.00	\$ -			1.00	\$ 3,900.00	- \$	-	1.00	\$ 3,900.00	100%	0.00	\$ -
Crushcrete Road Base	6,950.00	SY	14.00	\$ 97,300.00	6,950.00	\$ -			6,950.00	\$ 97,300.00	- \$	-	6,950.00	\$ 97,300.00	100%	0.00	\$ -
12" HP	360.00	LF	75.00	\$ 27,000.00	360.00	\$ -			360.00	\$ 27,000.00	- \$	-	360.00	\$ 27,000.00	100%	0.00	\$ -

PARTIAL RELEASE OF CLAIM OF LIEN

The undersigned lienor, in consideration of payment in the amount of \$56,624.75, hereby partially releases its claim of lien for labor, services, or materials furnished to Six Mile Creek CDD, on the job of Trailmark EP PH3, for the following described property:

Trailmark East Parcel Phase 3

The undersigned lienor acknowledges previous receipt of \$8,150,042.91 and is executing this waiver and release in exchange for a check or checks in the additional amount of \$56,624.75, this partial release of claim of lien expressly and totally is conditioned on receipt of the check or checks and the collection of the funds in the amount of \$56,624.75.

There remains unpaid \$858,754.63.

Dated: November 25, 20 24

Signed and sealed in the presence of:

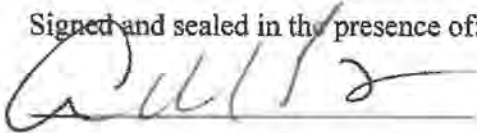

Witness



Lienor

STATE OF FLORIDA
COUNTY OF Duval

I HEREBY CERTIFY that on this day, November 25, 2024 before me, an officer duly authorized in the State aforesaid and in the County aforesaid to take acknowledgments, personally appeared Charles D. Freshwater, as President of Jax Utilities Management, Inc. a Florida corporation, on behalf of the corporation, and she/he acknowledged before me that she/he executed the same and did so by order of the Board of Directors of the Corporation.

He/She is personally known to me produced N/A as identification





Notary Public

REQUISITION NO. 82A
(2023 Acquisition and Construction Account)

SIX MILE CREEK COMMUNITY DEVELOPMENT DISTRICT
(ST. JOHNS COUNTY, FLORIDA)

\$10,515,000
Capital Improvement Revenue Bonds
Series 2023 (2023 Project Area)

The undersigned, an Authorized Officer of Six Mile Creek Community Development District (the "District") hereby submits the following requisition for disbursement under and pursuant to the terms of the Master Trust Indenture from the District to U.S. Bank Trust Company, National Association, as successor trustee (the "Trustee"), dated as of July 1, 2007 (the "Master Indenture"), as amended and supplemented by the Eleventh Supplemental Trust Indenture between the District and Trustee, dated as of June 1, 2023 (the Master Indenture as amended and supplemented is hereinafter referred to as the "Indenture") (all capitalized terms used herein shall have the meaning ascribed to such term in the Indenture):

(A) Requisition Number: **82A**

(B) Name of Payee: **Wire Transfer Instructions:**
Jax Utilities Management, Inc.
Truist Bank
214 North Tryon St.
Charlotte, NC 28202
ABA:
Beneficiary: JAX UTILITIES MANAGEMENT
INC (Business Account Title) Account #: Routing #:

\$ 88,093.50

(C) Amount Payable:

(D) Purpose for which paid or incurred (refer also to specific contract if amount is due and payable pursuant to a contract involving progress payments, or, state Costs of Issuance, if applicable): **Trailmark Phase 12, Application No. 21 (November 2024)**

(E) Fund or Account and subaccount, if any, from which disbursement is to be made:

\$ _____ Assessment Area 2 – Phase 3C Subaccount

\$ 88,093.50 Assessment Area 3 – Phase 3 Subaccount

The undersigned hereby certifies that obligations in the stated amount set forth above have been incurred by the District, that each disbursement set forth above is a proper charge against the 2023 Acquisition and Construction Account and the subaccount, if any, referenced above, that each disbursement set forth above was incurred in connection with the acquisition and construction

of the 2023 Project and each represents a Cost of the 2023 Project, and has not previously been paid.

The undersigned hereby further certifies that there has not been filed with or served upon the District notice of any lien, right to lien, or attachment upon, or claim affecting the right to receive payment of, any of the moneys payable to the Payee set forth above, which has not been released or will not be released simultaneously with the payment hereof.

The undersigned hereby further certifies that such requisition contains no item representing payment on account of any retained percentage which the District is at the date of such certificate entitled to retain.

If this requisition is for a disbursement from other than the Costs of Issuance Account or for payment of capitalized interest, there shall be attached a resolution of the Governing Body of the District approving this requisition or approving the specific contract with respect to which disbursements pursuant to this requirement are due and payable.

Attached hereto are originals of the invoice(s) from the vendor of the property acquired or the services rendered with respect to which disbursement is hereby requested.

**SIX MILE CREEK COMMUNITY
DEVELOPMENT DISTRICT**

By: _____
Gregg F. Kern
Chairperson, Board of Supervisors

**CONSULTING ENGINEER'S APPROVAL FOR NON-COST OF ISSUANCE AND
CAPITALIZED INTEREST REQUESTS ONLY**

If this requisition is for a disbursement from other than Capitalized Interest or Costs of Issuance, the undersigned Consulting Engineer hereby certifies that this disbursement is for a Cost of the 2023 Project and is consistent with: (i) the applicable acquisition or construction contract; (ii) the plans and specifications for the portion of the 2023 Project with respect to which such disbursement is being made; and, (iii) the report of the Consulting Engineer attached as an Exhibit to the Eleventh Supplemental Trust Indenture, as such report shall have been amended or modified on the date hereof.

By:  _____
Consulting Engineer

APPLICATION AND CERTIFICATION FOR PAYMENT

AIA DOCUMENT G702



FROM (CONTRACTOR):
Jax Utilities Management, Inc
 5465 Verna Boulevard
 Jacksonville, FL 32205

TO (OWNER):
Six Mile Creek CDD
 c/o England-Thims & Miller, Inc.
 14775 Old St. Augustine Road
 Jacksonville, FL 32258

CONTRACT FOR:
 Underground Infrastructure

APPLICATION NO: 21

Reviewed and
 Accurate to Site
 Conditions.

PERIOD TO: November 25, 2024

PROJECT: Trailmark PH 12

Pong L. 12-4-24

CONTRACTORS APPLICATION FOR PAYMENT

Application is made for payment, as shown below, in connection with the Contract. Continuation sheet, AIA Document G703, is attached.

CHANGE ORDER SUMMARY		ADDITIONS	DEDUCTIONS
Change Orders approved in previous months by Owner			
Approved this Month			
Number	Date Approved		
1	04/19/23	722,431.60	
2	03/13/23	462,598.75	
3	05/17/23		(42,800.00)
4	06/05/23	301,081.75	
5	06/14/23		(1,410,064.73)
6	07/26/23	411,000.00	
7	10/18/23		(16,671.25)
8	12/12/23		(1,194,560.00)
9	01/24/24	1,500.00	
10	01/30/24	88,970.00	
11	02/01/24	96,750.00	
12	02/01/24	7,105.00	
13	03/06/24	4,300.00	
14	04/10/24	0.00	
15	04/10/24	3,000.00	
16	05/30/24		(156,050.50)
17	06/05/24	52,906.00	
18	07/10/24	37,090.00	
19	08/22/24	2,800.00	
20	08/27/24	12,908.00	
21	09/13/24	115,050.00	
TOTALS		2,319,491.10	(2,820,146.48)
Net change by Change Orders		(500,655.38)	

1. ORIGINAL CONTRACT SUM	<u>\$11,492,616.00</u>
2. Net Change by Change Orders	<u>-\$500,655.38</u>
3. CONTRACT SUM TO DATE (LINE 1 +,- 2)	<u>\$10,991,960.62</u>
4. TOTAL COMPLETED AND STORED TO DATE	<u>\$10,932,840.62</u>
5. RETAINAGE	
a. 5% % (Column D+E on G703)	
Total retainage (Line 5a, or Total in Column J of G703)	<u>\$546,642.03</u>
6. TOTAL EARNED LESS RETAINAGE (Line 4 less Line 5 Total)	<u>\$10,386,198.59</u>
7. LESS PREVIOUS CERTIFICATES FOR PAYMENT (Line 6 from prior Certificate)	<u>\$10,298,105.09</u>
8. CURRENT PAYMENT DUE	<u>\$88,093.50</u>
9. BALANCE TO FINISH, PLUS RETAINAGE (Line 3 less Line 6)	<u>\$605,762.03</u>

State of: Florida County of: Duval
 Subscribed and sworn before me this 13 day of November, 2024
 Notary Public: [Signature]
 My Commission expires August 17, 2026

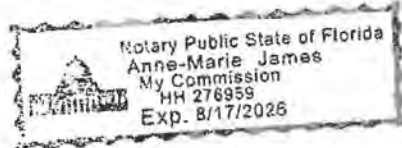

The undersigned Contractor certifies that to the best of the Contractor's knowledge, information and belief the Work covered by this Application for Payment has been completed in accordance with the Contract Documents, that all amounts have been paid for by the Contractor for Work for which previous Certificates for Payment were issued and payments received from the Owner, and

CONTRACTOR: Jax Utilities Management, Inc

By: [Signature] Date: 11/25/2024

ENGINEERS CERTIFICATE FOR PAYMENT

In accordance with the Contract Documents, based on on-site observations and the data comprising the above application, the Architect certifies to the Owner that to the best of the Engineers knowledge, information and belief the Work has progressed as indicated, the quality of the Work is in accordance with the Contract Documents, and the Contractor is entitled to payment of the AMOUNT CERTIFIED.

AMOUNT CERTIFIED: \$88,093.50
 ENGINEER: England-Thims & Miller, Inc.
 BY: [Signature] DATE: 12/9/2024

This Certificate is not negotiable. The AMOUNT CERTIFIED is payable only to the Contractor named herein. Issuance, payment and acceptance of payments are without prejudice to any rights of the Owner or Contractor under this Contract

Project Number: 22-2247
 Project Name: Trailmark 12
 Owner Name: ET&M
 Contract Number: 22-260
 For Month Ending: 11/25/2024

Period Ending: 11/25/24
 Variance: \$0.00
 Projected Final: \$10,991,960.67
 Billings To Date: \$10,932,840.62

Remaining Billings: \$59,120.00

Bid Items	Original Contract Amt				Prty. Quantity	Contract		Materials Amount	To Date		Remaining		Projected Final		% Complete	Projection vs. Original	
	Qty	UM	Unit Price	L&E Total Amount		Quantity	Amount		Quantity	Amount	Quantity	Amount	Quantity	Amount		Quantity	Amount
Mobilizations	1.00	LS	74,000.00	\$ 74,000.00	1.00	\$ -	-	1.00	\$ 74,000.00	-	\$ -	1.00	\$ 74,000.00	100%	0.00	\$ -	
Survey	1.00	LS	49,500.00	\$ 49,500.00	1.00	\$ -	-	1.00	\$ 49,500.00	-	\$ -	1.00	\$ 49,500.00	100%	0.00	\$ -	
MOT	1.00	LS	3,000.00	\$ 3,000.00	1.00	\$ -	-	1.00	\$ 3,000.00	-	\$ -	1.00	\$ 3,000.00	100%	0.00	\$ -	
Demolition	1.00	LS	2,500.00	\$ 2,500.00	1.00	\$ -	-	1.00	\$ 2,500.00	-	\$ -	1.00	\$ 2,500.00	100%	0.00	\$ -	
Total				\$ 129,000.00		\$ -			\$ 129,000.00		\$ 0.00		\$ 129,000.00	100.00%		\$ -	
CLEARING AND GRUBBING																	
Clearing	74.00	AC	5,600.00	\$ 414,800.00	74.00	\$ -	-	74.00	\$ 414,800.00	-	\$ -	74.00	\$ 414,800.00	100%	0.00	\$ -	
Stumpage	74.00	AC	3,600.00	\$ 267,600.00	74.00	\$ -	-	74.00	\$ 267,600.00	-	\$ -	74.00	\$ 267,600.00	100%	0.00	\$ -	
Total				\$ 682,400.00		\$ -			\$ 682,400.00		\$ 0.00		\$ 682,400.00	100.00%		\$ -	
UNSUITABLE MATERIAL																	
Remove & Replace Unsuitable	66,800.00	CY	11.00	\$ 734,800.00	66,800.00	\$ -	-	66,800.00	\$ 734,800.00	-	\$ -	66,800.00	\$ 734,800.00	100%	0.00	\$ -	
Total				\$ 734,800.00		\$ -			\$ 734,800.00		\$ 0.00		\$ 734,800.00	100.00%		\$ -	
STORMWATER MNGT.																	
Pond Excavation	184,700.00	CY	3.75	\$ 692,625.00	184,700.00	\$ -	-	184,700.00	\$ 692,625.00	-	\$ -	184,700.00	\$ 692,625.00	100%	0.00	\$ -	
Dewatering	1.00	LS	103,000.00	\$ 103,000.00	1.00	\$ -	-	1.00	\$ 103,000.00	-	\$ -	1.00	\$ 103,000.00	100%	0.00	\$ -	
Total				\$ 795,625.00		\$ -			\$ 795,625.00		\$ 0.00		\$ 795,625.00	100.00%		\$ -	
EARTHWORK																	
Roadway Exc - Import - Rough Grade	41,000.00	CY	25.00	\$ 1,025,000.00	41,000.00	\$ -	-	41,000.00	\$ 1,025,000.00	-	\$ -	41,000.00	\$ 1,025,000.00	100%	0.00	\$ -	
R/W Drest Up	12,540.00	CY	2.00	\$ 25,080.00	12,540.00	\$ -	-	12,540.00	\$ 25,080.00	-	\$ -	12,540.00	\$ 25,080.00	100%	0.00	\$ -	
Misc. Site & Swale Grading	1.00	LS	49,000.00	\$ 49,000.00	1.00	\$ -	-	1.00	\$ 49,000.00	-	\$ -	1.00	\$ 49,000.00	100%	0.00	\$ -	
Lot Fill from Site	184,800.00	CY	1.25	\$ 231,000.00	184,800.00	\$ -	-	184,800.00	\$ 231,000.00	-	\$ -	184,800.00	\$ 231,000.00	100%	0.00	\$ -	
Lot Fill - Import	51,000.00	CY	24.00	\$ 1,224,000.00	51,000.00	\$ -	-	51,000.00	\$ 1,224,000.00	-	\$ -	51,000.00	\$ 1,224,000.00	100%	0.00	\$ -	
Lot Grading & Dress	1.00	LS	54,000.00	\$ 54,000.00	1.00	\$ -	-	1.00	\$ 54,000.00	-	\$ -	1.00	\$ 54,000.00	100%	0.00	\$ -	
Pond Liner	1.00	LS	18,000.00	\$ 18,000.00	1.00	\$ -	-	1.00	\$ 18,000.00	-	\$ -	1.00	\$ 18,000.00	100%	0.00	\$ -	
Total				\$ 2,627,000.00		\$ -			\$ 2,627,000.00		\$ 0.00		\$ 2,627,000.00	100.00%		\$ -	
ROADWAY CONSTRUCTION																	
Miami Curb	11,800.00	LF	15.00	\$ 177,000.00	11,800.00	\$ -	-	11,800.00	\$ 177,000.00	-	\$ -	11,800.00	\$ 177,000.00	100%	0.00	\$ -	
Standard Curb	700.00	LF	26.00	\$ 18,200.00	700.00	\$ -	-	700.00	\$ 18,200.00	-	\$ -	700.00	\$ 18,200.00	100%	0.00	\$ -	
6" Roadway Base	16,600.00	SY	18.50	\$ 307,100.00	16,600.00	\$ -	-	16,600.00	\$ 307,100.00	-	\$ -	16,600.00	\$ 307,100.00	100%	0.00	\$ -	
12" Stabilized Subgrade	19,380.00	SY	9.50	\$ 184,110.00	19,380.00	\$ -	-	19,380.00	\$ 184,110.00	-	\$ -	19,380.00	\$ 184,110.00	100%	0.00	\$ -	
Asphalt 1" First Lift SP 12.5	16,600.00	SY	12.00	\$ 199,200.00	16,600.00	\$ -	-	16,600.00	\$ 199,200.00	-	\$ -	16,600.00	\$ 199,200.00	100%	0.00	\$ -	
Prime	16,600.00	SY	3.00	\$ 49,800.00	16,600.00	\$ -	-	16,600.00	\$ 49,800.00	-	\$ -	16,600.00	\$ 49,800.00	100%	0.00	\$ -	
Pavement Markings	1.00	LS	18,000.00	\$ 18,000.00	1.00	\$ -	-	1.00	\$ 18,000.00	-	\$ -	1.00	\$ 18,000.00	100%	0.00	\$ -	
Stewalk	100.00	SY	75.00	\$ 7,500.00	100.00	\$ -	-	100.00	\$ 7,500.00	-	\$ -	100.00	\$ 7,500.00	100%	0.00	\$ -	
ADA Ramps	12.00	EA	2,500.00	\$ 30,000.00	12.00	\$ -	-	12.00	\$ 30,000.00	-	\$ -	12.00	\$ 30,000.00	100%	0.00	\$ -	
Access Roads w/ Fabric	450.00	SY	95.00	\$ 42,750.00	450.00	\$ -	-	450.00	\$ 42,750.00	-	\$ -	450.00	\$ 42,750.00	100%	0.00	\$ -	
Total				\$ 1,822,000.00		\$ -			\$ 1,822,000.00		\$ 0.00		\$ 1,822,000.00	100.00%		\$ -	
STORM DRAINAGE SYSTEM																	
15" RCP	1,192.00	LF	40.00	\$ 47,680.00	1,192.00	\$ -	-	1,192.00	\$ 47,680.00	-	\$ -	1,192.00	\$ 47,680.00	100%	0.00	\$ -	
18" RCP	537.00	LF	49.25	\$ 26,468.75	537.00	\$ -	-	537.00	\$ 26,468.75	-	\$ -	537.00	\$ 26,468.75	100%	0.00	\$ -	
24" RCP	867.00	LF	70.35	\$ 60,993.45	867.00	\$ -	-	867.00	\$ 60,993.45	-	\$ -	867.00	\$ 60,993.45	100%	0.00	\$ -	
30" RCP	1,191.00	LF	100.88	\$ 120,148.08	1,191.00	\$ -	-	1,191.00	\$ 120,148.08	-	\$ -	1,191.00	\$ 120,148.08	100%	0.00	\$ -	
36" RCP	173.00	LF	172.50	\$ 29,842.50	173.00	\$ -	-	173.00	\$ 29,842.50	-	\$ -	173.00	\$ 29,842.50	100%	0.00	\$ -	
42" RCP	170.00	LF	227.00	\$ 38,590.00	170.00	\$ -	-	170.00	\$ 38,590.00	-	\$ -	170.00	\$ 38,590.00	100%	0.00	\$ -	
54" RCP	374.00	LF	455.00	\$ 170,170.00	374.00	\$ -	-	374.00	\$ 170,170.00	-	\$ -	374.00	\$ 170,170.00	100%	0.00	\$ -	
12-15-18" MES	12.00	EA	683.90	\$ 7,966.80	12.00	\$ -	-	12.00	\$ 7,966.80	-	\$ -	12.00	\$ 7,966.80	100%	0.00	\$ -	
24" MES	4.00	EA	1,029.80	\$ 4,119.20	4.00	\$ -	-	4.00	\$ 4,119.20	-	\$ -	4.00	\$ 4,119.20	100%	0.00	\$ -	
10" MES	3.00	EA	1,349.95	\$ 4,049.85	3.00	\$ -	-	3.00	\$ 4,049.85	-	\$ -	3.00	\$ 4,049.85	100%	0.00	\$ -	
36" MES	6.00	EA	1,739.35	\$ 10,436.10	6.00	\$ -	-	6.00	\$ 10,436.10	-	\$ -	6.00	\$ 10,436.10	100%	0.00	\$ -	
54" MES	1.00	EA	33,000.00	\$ 33,000.00	1.00	\$ -	-	1.00	\$ 33,000.00	-	\$ -	1.00	\$ 33,000.00	100%	0.00	\$ -	
Curb Inlets	24.00	EA	2,959.40	\$ 71,025.60	24.00	\$ -	-	24.00	\$ 71,025.60	-	\$ -	24.00	\$ 71,025.60	100%	0.00	\$ -	
Double Curb Inlets	9.00	EA	3,349.00	\$ 30,141.00	9.00	\$ -	-	9.00	\$ 30,141.00	-	\$ -	9.00	\$ 30,141.00	100%	0.00	\$ -	
12x18 ERCP	53.00	LF	41.55	\$ 2,202.15	53.00	\$ -	-	53.00	\$ 2,202.15	-	\$ -	53.00	\$ 2,202.15	100%	0.00	\$ -	
Manholes	5.00	EA	2,858.75	\$ 14,293.75	5.00	\$ -	-	5.00	\$ 14,293.75	-	\$ -	5.00	\$ 14,293.75	100%	0.00	\$ -	

Project Number: 22-2247
 Project Name: Trailmark 12
 Owner Name: ET&M
 Contract Number: 22-260
 For Month Ending: 11/25/2024

Period Ending: 11/25/24
 Variance: \$0.00
 Projected Final: \$10,991,960.62
 Billings To Date: \$10,932,840.62
 Remaining Billings: \$59,120.00

Bid Items	Original Contract Amt				L&E Total Amount	Prog. Quantity	Current		Materials Amount	To Date		Resolving		Projected Final		% Complete	Projection vs. Original	
	Qty	UM	Unit Price				Quantity	Amount		Quantity	Amount	Quantity	Amount	Quantity	Amount		Quantity	Amount
ROADWAY UNDERDRAIN																		
Underdrain Stubs	1,360.000	LF	\$ 27.56	\$ 37,481.60	1,360.00	\$ -	-	24,198.89	1,360.00	\$ 51,680.00	-	\$ -	1,360.00	\$ 51,680.00	100%	0.000	\$ -	
Adjustments	47.000	EA	\$ 800.00	\$ 37,600.00	47.00	\$ -	-	-	47.00	\$ 37,600.00	-	\$ -	47.00	\$ 37,600.00	100%	0.000	\$ -	
TV Storm	4,551.000	LF	\$ 18.00	\$ 81,918.00	4,551.00	\$ -	-	-	4,551.00	\$ 81,918.00	-	\$ -	4,551.00	\$ 81,918.00	100%	0.000	\$ -	
Type C Inlet	5.000	EA	\$ 2,839.15	\$ 14,195.75	5.00	\$ -	-	11,804.25	5.00	\$ 14,000.00	-	\$ -	5.00	\$ 26,000.00	100%	0.000	\$ -	
Type E Inlet	4.000	EA	\$ 9,211.92	\$ 36,847.68	4.00	\$ -	-	29,552.32	4.00	\$ 66,400.00	-	\$ -	4.00	\$ 66,400.00	100%	0.000	\$ -	
Remove and Replace Unsuitable Mnt.	4,000.000	CY	\$ 28.00	\$ 112,000.00	4,000.00	\$ -	-	-	4,000.00	\$ 112,000.00	-	\$ -	4,000.00	\$ 112,000.00	100%	0.000	\$ -	
Total				\$ 291,138.00		\$ -	-	\$ 85,754.89		\$ 243,383.00		\$ 0.00		\$ 291,138.00	100%		\$ -	
ROADWAY UNDERDRAIN																		
Roadway Underdrains	4,000.000	LF	\$ 38.00	\$ 152,000.00	4,000.00	\$ -	-	-	4,000.00	\$ 152,000.00	-	\$ -	4,000.00	\$ 152,000.00	100%	0.000	\$ -	
Total				\$ 152,000.00		\$ -	-	-		\$ 152,000.00		\$ 0.00		\$ 152,000.00	100%		\$ -	
PAVING & DRAINAGE AS-BUILTS																		
Paving & Drainage As-Builts	1.000	LS	\$ 44,000.00	\$ 44,000.00	0.95	\$ 41,800.00	\$ 41,800.00	0.95	\$ 41,800.00	\$ 41,800.00	0.05	\$ 2,200.00	1.00	\$ 44,000.00	95%	0.000	\$ -	
Total				\$ 44,000.00		\$ 41,800.00	\$ 41,800.00		\$ 41,800.00	\$ 41,800.00	\$ 2,200.00		\$ 44,000.00	95%		\$ -		
SICUD WATER DISTR. SYSTEM																		
12" Watermain	326.000	LF	\$ 128.00	\$ 41,728.00	326.00	\$ -	-	21,516.00	326.00	\$ 63,244.00	-	\$ -	326.00	\$ 63,244.00	100%	0.000	\$ -	
8" Watermain	4,955.000	LF	\$ 53.30	\$ 264,101.50	4,955.00	\$ -	-	152,118.50	4,955.00	\$ 416,220.00	-	\$ -	4,955.00	\$ 416,220.00	100%	0.000	\$ -	
4" Watermain	111.000	LF	\$ 36.16	\$ 4,013.76	111.00	\$ -	-	1,980.24	111.00	\$ 5,994.00	-	\$ -	111.00	\$ 5,994.00	100%	0.000	\$ -	
2" Watermain	540.000	LF	\$ 16.70	\$ 9,018.00	540.00	\$ -	-	1,242.00	540.00	\$ 10,260.00	-	\$ -	540.00	\$ 10,260.00	100%	0.000	\$ -	
Tie-ins	3.000	EA	\$ 5,707.00	\$ 17,121.00	3.00	\$ -	-	5,079.00	3.00	\$ 22,200.00	-	\$ -	3.00	\$ 22,200.00	100%	0.000	\$ -	
16" Road Crossing	1.000	EA	\$ 6,803.25	\$ 6,803.25	1.00	\$ -	-	3,796.75	1.00	\$ 10,600.00	-	\$ -	1.00	\$ 10,600.00	100%	0.000	\$ -	
10" Road Crossings	3.000	EA	\$ 6,993.35	\$ 20,980.05	3.00	\$ -	-	7,689.95	3.00	\$ 28,500.00	-	\$ -	3.00	\$ 28,500.00	100%	0.000	\$ -	
Fire Hydrants w/ Gate Valve	15.000	EA	\$ 1,335.93	\$ 20,038.95	15.00	\$ -	-	75,981.05	15.00	\$ 96,000.00	-	\$ -	15.00	\$ 96,000.00	100%	0.000	\$ -	
Flushing Hydrants	4.000	EA	\$ 2,189.20	\$ 8,756.79	4.00	\$ -	-	6,443.21	4.00	\$ 15,200.00	-	\$ -	4.00	\$ 15,200.00	100%	0.000	\$ -	
Services	186.000	EA	\$ 406.12	\$ 75,538.32	186.00	\$ -	-	65,921.68	186.00	\$ 141,360.00	-	\$ -	186.00	\$ 141,360.00	100%	0.000	\$ -	
Test & Chlorinate	6,052.000	LF	\$ 1.00	\$ 6,052.00	6,052.00	\$ -	-	-	6,052.00	\$ 6,052.00	-	\$ -	6,052.00	\$ 6,052.00	100%	0.000	\$ -	
Adjustments	1.000	LA	\$ 12,900.00	\$ 12,900.00	1.00	\$ -	-	-	1.00	\$ 12,900.00	-	\$ -	1.00	\$ 12,900.00	100%	0.000	\$ -	
Total				\$ 489,813.43		\$ -	-	\$ 241,938.99		\$ 878,130.00		\$ 0.00		\$ 878,130.00	100%		\$ -	
SICUD SEWER SYSTEM																		
12" Sewer Main	5,753.000	LF	\$ 69.47	\$ 399,680.91	5,753.00	\$ -	-	89,344.09	5,753.00	\$ 489,005.00	-	\$ -	5,753.00	\$ 489,005.00	100%	0.000	\$ -	
Manholes	28.000	EA	\$ 5,255.04	\$ 147,158.00	28.00	\$ -	-	158,042.00	28.00	\$ 305,200.00	-	\$ -	28.00	\$ 305,200.00	100%	0.000	\$ -	
Services	186.000	EA	\$ 43.00	\$ 7,998.00	186.00	\$ -	-	147,312.00	186.00	\$ 155,310.00	-	\$ -	186.00	\$ 155,310.00	100%	0.000	\$ -	
Dewater	1.000	LS	\$ 162,000.00	\$ 162,000.00	1.00	\$ -	-	-	1.00	\$ 162,000.00	-	\$ -	1.00	\$ 162,000.00	100%	0.000	\$ -	
Adjustments	1.000	LS	\$ 29,700.00	\$ 29,700.00	1.00	\$ -	-	-	1.00	\$ 29,700.00	-	\$ -	1.00	\$ 29,700.00	100%	0.000	\$ -	
Tv Testing	6,263.000	LF	\$ 10.00	\$ 62,630.00	6,263.00	\$ -	-	-	6,263.00	\$ 62,630.00	-	\$ -	6,263.00	\$ 62,630.00	100%	0.000	\$ -	
Connect To Existing	2.000	EA	\$ 7,500.00	\$ 15,000.00	2.00	\$ -	-	-	2.00	\$ 15,000.00	-	\$ -	2.00	\$ 15,000.00	100%	0.000	\$ -	
Benchdown & Backfill	1.000	LS	\$ 26,000.00	\$ 26,000.00	1.00	\$ -	-	-	1.00	\$ 26,000.00	-	\$ -	1.00	\$ 26,000.00	100%	0.000	\$ -	
Remove & Replace (unsult. Material)	6,000.000	CY	\$ 28.00	\$ 168,000.00	6,000.00	\$ -	-	-	6,000.00	\$ 168,000.00	-	\$ -	6,000.00	\$ 168,000.00	100%	0.000	\$ -	
Total				\$ 675,246.91		\$ -	-	\$ 264,696.09		\$ 1,412,645.00		\$ 0.00		\$ 1,412,645.00	100%		\$ -	
SICUD FORCEMAIN SYSTEM																		
4" Force Main	1,343.000	LF	\$ 31.65	\$ 42,505.95	1,343.00	\$ -	-	13,900.05	1,343.00	\$ 56,406.00	-	\$ -	1,343.00	\$ 56,406.00	100%	0.000	\$ -	
Testing	1.000	LS	\$ 2,000.00	\$ 2,000.00	1.00	\$ -	-	-	1.00	\$ 2,000.00	-	\$ -	1.00	\$ 2,000.00	100%	0.000	\$ -	
Total				\$ 44,505.95		\$ -	-	\$ 13,900.05		\$ 58,406.00		\$ 0.00		\$ 58,406.00	100%		\$ -	
WATER & SEWER AS-BUILTS																		
Water & Sewer As-Builts	1.000	LS	\$ 44,000.00	\$ 44,000.00	0.90	\$ 41,800.00	\$ 41,800.00	0.95	\$ 41,800.00	\$ 41,800.00	0.05	\$ 2,200.00	1.00	\$ 44,000.00	95%	0.000	\$ -	
Total				\$ 44,000.00		\$ 41,800.00	\$ 41,800.00		\$ 41,800.00	\$ 41,800.00	\$ 2,200.00		\$ 44,000.00	95%		\$ -		
SLEEVES - IRRIG. - ELEC. - TELE. - CATV																		
2"	4,000.000	LF	\$ 12.00	\$ 48,000.00	4,000.00	\$ -	-	-	4,000.00	\$ 48,000.00	-	\$ -	4,000.00	\$ 48,000.00	100%	0.000	\$ -	
3"	3,500.000	LF	\$ 14.00	\$ 49,000.00	3,500.00	\$ -	-	-	3,500.00	\$ 49,000.00	-	\$ -	3,500.00	\$ 49,000.00	100%	0.000	\$ -	
4"	4,500.000	LF	\$ 16.00	\$ 72,000.00	4,500.00	\$ -	-	-	4,500.00	\$ 72,000.00	-	\$ -	4,500.00	\$ 72,000.00	100%	0.000	\$ -	
6"	3,000.000	LF	\$ 18.00	\$ 54,000.00	3,000.00	\$ -	-	-	3,000.00	\$ 54,000.00	-	\$ -	3,000.00	\$ 54,000.00	100%	0.000	\$ -	
Total				\$ 223,000.00		\$ -	-	-		\$ 223,000.00		\$ 0.00		\$ 223,000.00	100%		\$ -	
FFL ELEC. ALLOWANCE																		
Per Bid Docs	1.000	LS	\$ 175,000.00	\$ 175,000.00	1.00	\$ -	-	-	1.00	\$ 175,000.00	-	\$ -	1.00	\$ 175,000.00	100%	0.000	\$ -	

Project Number: 22-2247
 Project Name: Trailmark 12
 Owner Name: ETBM
 Contract Number: 22-260
 For Month Ending: 11/25/2024

Period Ending: 11/25/24
 Variance \$0.00
 Projected Final \$10,991,960.62
 Billings To Date \$10,932,840.62
 Remaining Billings \$59,120.00

Bid Items	Original Contract Amt				Prev. Quantity	Contract		Materials Amount	To Date		Remaining		Projected Final		%	Projection vs. Original	
	Qty	UM	Unit Price	L&E Total Amount		Quantity	Amount		Quantity	Amount	Quantity	Amount	Quantity	Amount		Quantity	Amount
Total				\$ 175,000.00					7	\$ 175,000.00		\$ 0.00		\$ 175,000.00	100.00%		\$ 0.00
SEEDING & SOD																	
Seeding Lots	175,000.000	SY	\$ 0.50	\$ 87,500.00	175,000.00	\$ -			175,000.00	\$ 87,500.00	\$ -	\$ -	175,000.00	\$ 87,500.00	100%	0.000	\$ -
Seeding R/W	39,000.000	SY	\$ 0.50	\$ 19,500.00	39,000.00	\$ -			39,000.00	\$ 19,500.00	\$ -	\$ -	39,000.00	\$ 19,500.00	100%	0.000	\$ -
Sod Ponds	25,600.000	SY	\$ 4.00	\$ 102,400.00	25,600.00	\$ -			25,600.00	\$ 102,400.00	\$ -	\$ -	25,600.00	\$ 102,400.00	100%	0.000	\$ -
Sod Back of Lots & Swales	14,200.000	SY	\$ 4.00	\$ 56,800.00	14,200.00	\$ -			14,200.00	\$ 56,800.00	\$ -	\$ -	14,200.00	\$ 56,800.00	100%	0.000	\$ -
Back of Curb & Edge of Pavement	2,400.000	SY	\$ 4.00	\$ 9,600.00	2,400.00	\$ -			2,400.00	\$ 9,600.00	\$ -	\$ -	2,400.00	\$ 9,600.00	100%	0.000	\$ -
Total				\$ 279,800.00					7	\$ 279,800.00		\$ 0.00		\$ 279,800.00	100.00%		\$ 0.00
EROSION CONTROL																	
Erosion Control NPDES	1.000	LS	\$ 18,000.00	\$ 18,000.00	1.00	\$ -			1.00	\$ 18,000.00	\$ -	\$ -	1.00	\$ 18,000.00	100%	0.000	\$ -
Silt Fence	15,500.000	LF	\$ 3.50	\$ 54,250.00	15,500.00	\$ -			15,500.00	\$ 54,250.00	\$ -	\$ -	15,500.00	\$ 54,250.00	100%	0.000	\$ -
Construction Entrance	1.000	LS	\$ 5,000.00	\$ 5,000.00	1.00	\$ -			1.00	\$ 5,000.00	\$ -	\$ -	1.00	\$ 5,000.00	100%	0.000	\$ -
Inlet Protection	42.000	EA	\$ 440.00	\$ 18,480.00	42.00	\$ -			42.00	\$ 18,480.00	\$ -	\$ -	42.00	\$ 18,480.00	100%	0.000	\$ -
Turbidity Control	1.000	LS	\$ 76,000.00	\$ 76,000.00	1.00	\$ -			1.00	\$ 76,000.00	\$ -	\$ -	1.00	\$ 76,000.00	100%	0.000	\$ -
Total				\$ 172,730.00					7	\$ 172,730.00		\$ 0.00		\$ 172,730.00	100.00%		\$ 0.00
STORMWATER POLLUTION PLAN																	
SWPPP	1.000	LS	\$ 12,000.00	\$ 12,000.00	1.00	\$ -			1.00	\$ 12,000.00	\$ -	\$ -	1.00	\$ 12,000.00	100%	0.000	\$ -
Total				\$ 12,000.00					1	\$ 12,000.00		\$ 0.00		\$ 12,000.00	100.00%		\$ 0.00
BOND																	
Payment & Performance Bonds	1.000	LS	\$ 175,000.00	\$ 175,000.00	1.00	\$ -			1.00	\$ 175,000.00	\$ -	\$ -	1.00	\$ 175,000.00	100%	0.000	\$ -
Contractor Warranty	1.000	LS	\$ 28,000.00	\$ 28,000.00		\$ -				\$ -	\$ 28,000.00	\$ -	1.00	\$ 28,000.00	0%	0.000	\$ -
Total				\$ 203,000.00					1	\$ 175,000.00	\$ 28,000.00	\$ -	1	\$ 203,000.00	80.31%		\$ 0.00
RETAINING WALL																	
Retaining Wall	1.000	LS	\$ 379,500.00	\$ 379,500.00	1.00	\$ -			1.00	\$ 379,500.00	\$ -	\$ -	1.00	\$ 379,500.00	100%	0.000	\$ -
Total				\$ 379,500.00					1	\$ 379,500.00		\$ 0.00		\$ 379,500.00	100.00%		\$ 0.00
CHANGE ORDERS																	
Change Order	Qty	UM	Unit Price	Total Amount	To Date Quantity	Amount	To Date Quantity	Amount	Remaining Quantity	Amount	Projected Final Quantity	Amount	% Complete	Projection vs. Original Quantity	Amount		
Change Order 1																	
SOV Adjustment	1.000	LS	\$ 525,093.09	\$ 525,093.09	1.00	\$ -	1.00	\$ 722,491.60		\$ -	1.00	\$ 722,491.60	100%	0.000	\$ -		
Change Order 2																	
TM 4A Curb Repair	1.000	LS	\$ 5,888.00	\$ 5,888.00	1.00	\$ -	1.00	\$ 5,888.00		\$ -	1.00	\$ 5,888.00	100%	0.000	\$ -		
TM 4A Final Lift	1.000	LS	\$ 133,096.25	\$ 133,096.25	1.00	\$ -	1.00	\$ 133,096.25		\$ -	1.00	\$ 133,096.25	100%	0.000	\$ -		
TM 4D Curb Repair	1.000	LS	\$ 85,247.00	\$ 85,247.00	1.00	\$ -	1.00	\$ 85,247.00		\$ -	1.00	\$ 85,247.00	100%	0.000	\$ -		
TM 4D Final Lift	1.000	LS	\$ 238,367.50	\$ 238,367.50	1.00	\$ -	1.00	\$ 238,367.50		\$ -	1.00	\$ 238,367.50	100%	0.000	\$ -		
Change Order 3																	
ADS Credit	1.000	LS	\$ (42,800.00)	\$ (42,800.00)	1.00	\$ -	1.00	\$ (42,800.00)		\$ -	1.00	\$ (42,800.00)	100%	0.000	\$ -		
Change Order 4																	
TM 5A Curb Repair	1,901.000	LF	\$ 73.00	\$ 138,773.00	1,901.00	\$ -	1,901.00	\$ 138,773.00		\$ -	1,901.00	\$ 138,773.00	100%	0.000	\$ -		
TM 5A Sidewalk Repair	9.000	SY	\$ 62.00	\$ 558.00		\$ -	9.00	\$ 558.00		\$ -	9.00	\$ 558.00	100%	0.000	\$ -		
TM 5A SP 9.5 Asphalt Final UR	8,300.000	SY	\$ 13.25	\$ 109,975.00	8,300.00	\$ -	8,300.00	\$ 109,975.00		\$ -	8,300.00	\$ 109,975.00	100%	0.000	\$ -		
TM 7 Curb Repair	64.000	LF	\$ 73.00	\$ 4,672.00		\$ -	64.00	\$ 4,672.00		\$ -	64.00	\$ 4,672.00	100%	0.000	\$ -		
TM 7 SP 9.5 Asphalt Final Lift	3,555.000	SY	\$ 13.25	\$ 47,103.75	3,555.00	\$ -	3,555.00	\$ 47,103.75		\$ -	3,555.00	\$ 47,103.75	100%	0.000	\$ -		
Change Order 5																	
Ferguson Materials	1.000	LS	\$ (874,880.44)	\$ (874,880.44)	1.00	\$ -	1.00	\$ (874,880.44)		\$ -	1.00	\$ (874,880.44)	100%	0.000	\$ -		
Tax	1.000	LS	\$ (56,867.23)	\$ (56,867.23)	1.00	\$ -	1.00	\$ (56,867.23)		\$ -	1.00	\$ (56,867.23)	100%	0.000	\$ -		
American Precast	1.000	LS	\$ (442,474.00)	\$ (442,474.00)	1.00	\$ -	1.00	\$ (442,474.00)		\$ -	1.00	\$ (442,474.00)	100%	0.000	\$ -		
Tax	1.000	LS	\$ (28,760.81)	\$ (28,760.81)	1.00	\$ -	1.00	\$ (28,760.81)		\$ -	1.00	\$ (28,760.81)	100%	0.000	\$ -		
County Materials	1.000	LS	\$ (6,650.00)	\$ (6,650.00)	1.00	\$ -	1.00	\$ (6,650.00)		\$ -	1.00	\$ (6,650.00)	100%	0.000	\$ -		
Tax	1.000	LS	\$ (432.25)	\$ (432.25)	1.00	\$ -	1.00	\$ (432.25)		\$ -	1.00	\$ (432.25)	100%	0.000	\$ -		
Change Order 6																	
General Conditions - Wetland Outfall	1.000	LS	\$ 36,000.00	\$ 36,000.00	1.00	\$ -	1.00	\$ 36,000.00		\$ -	1.00	\$ 36,000.00	100%	0.000	\$ -		
NPDES & Erosion Control	1.000	LS	\$ 4,000.00	\$ 4,000.00	1.00	\$ -	1.00	\$ 4,000.00		\$ -	1.00	\$ 4,000.00	100%	0.000	\$ -		
Maintenance of Traffic	1.000	LS	\$ 40,000.00	\$ 40,000.00	1.00	\$ -	1.00	\$ 40,000.00		\$ -	1.00	\$ 40,000.00	100%	0.000	\$ -		

Project Number: 22-2247
 Project Name: Trailmark 12
 Owner Name: ET&M
 Contract Number: 22-26D
 For Month Ending: 11/25/2024

Period Ending: 11/25/24
 Variance: \$0.00
 Projected Final: \$10,992,840.62
 Billings To Date: \$10,992,840.62
 Remaining Billing: \$59,120.00

Bid Items	Original Contract Amt				L&E Total Amount	Prog. Quantity	Current		Materials Amount	To Date		Remaining		Projected Final		% Complete	Projection vs. Original	
	Qty	UM	Unit Price				Quantity	Amount		Quantity	Amount	Quantity	Amount	Quantity	Amount		Quantity	Amount
Demo/Ition	1.00	LS	\$ 6,000.00	\$ 6,000.00	1.00	\$ -	\$ -	1.00	\$ 6,000.00	-	\$ -	1.00	\$ 6,000.00	100%	0.00	\$ -		
Clearing & Earthwork	1.00	LS	\$ 70,000.00	\$ 70,000.00	1.00	\$ -	\$ -	1.00	\$ 70,000.00	-	\$ -	1.00	\$ 70,000.00	100%	0.00	\$ -		
Base & Paving	1.00	LS	\$ 40,000.00	\$ 40,000.00	1.00	\$ -	\$ -	1.00	\$ 40,000.00	-	\$ -	1.00	\$ 40,000.00	100%	0.00	\$ -		
Curbs & Concrete	1.00	LS	\$ 18,000.00	\$ 18,000.00	1.00	\$ -	\$ -	1.00	\$ 18,000.00	-	\$ -	1.00	\$ 18,000.00	100%	0.00	\$ -		
Storm Drain	1.00	LS	\$ 193,000.00	\$ 193,000.00	1.00	\$ -	\$ -	1.00	\$ 193,000.00	-	\$ -	1.00	\$ 193,000.00	100%	0.00	\$ -		
Grass	1.00	LS	\$ 4,000.00	\$ 4,000.00	1.00	\$ -	\$ -	1.00	\$ 4,000.00	-	\$ -	1.00	\$ 4,000.00	100%	0.00	\$ -		
Change Order 7				\$ -				\$ -				\$ -				\$ -		
Repairs: Damage by Allstate Elec.	1.00		\$ (16,671.25)	\$ (16,671.25)	1.00	\$ -	\$ -	1.00	\$ (16,671.25)	-	\$ -	1.00	\$ (16,671.25)	100%	0.00	\$ -		
Change Order 8				\$ -				\$ -				\$ -				\$ -		
Erosion Control NPDES- Rec Pond	1.00	LS	\$ 18,000.00	\$ 18,000.00	1.00	\$ -	\$ -	1.00	\$ 18,000.00	-	\$ -	1.00	\$ 18,000.00	100%	0.00	\$ -		
Silt Fence	4,200.00	LF	\$ 5.00	\$ 21,000.00	4,200.00	\$ -	\$ -	4,200.00	\$ 21,000.00	-	\$ -	4,200.00	\$ 21,000.00	100%	0.00	\$ -		
Clearing and Grubbing	13.00	AC	\$ 6,500.00	\$ 84,500.00	13.00	\$ -	\$ -	13.00	\$ 84,500.00	-	\$ -	13.00	\$ 84,500.00	100%	0.00	\$ -		
Stripping	13.00	AC	\$ 3,400.00	\$ 44,200.00	13.00	\$ -	\$ -	13.00	\$ 44,200.00	-	\$ -	13.00	\$ 44,200.00	100%	0.00	\$ -		
18" RCP	45.00	LF	\$ 130.00	\$ 5,850.00	45.00	\$ -	\$ -	45.00	\$ 5,850.00	-	\$ -	45.00	\$ 5,850.00	100%	0.00	\$ -		
30" RCP	26.00	LF	\$ 210.00	\$ 5,460.00	26.00	\$ -	\$ -	26.00	\$ 5,460.00	-	\$ -	26.00	\$ 5,460.00	100%	0.00	\$ -		
18" MES	3.00	EA	\$ 1,400.00	\$ 4,200.00	3.00	\$ -	\$ -	3.00	\$ 4,200.00	-	\$ -	3.00	\$ 4,200.00	100%	0.00	\$ -		
30" MES	1.00	EA	\$ 2,800.00	\$ 2,800.00	1.00	\$ -	\$ -	1.00	\$ 2,800.00	-	\$ -	1.00	\$ 2,800.00	100%	0.00	\$ -		
Type H Inlet	1.00	EA	\$ 17,300.00	\$ 17,300.00	1.00	\$ -	\$ -	1.00	\$ 17,300.00	-	\$ -	1.00	\$ 17,300.00	100%	0.00	\$ -		
TV Storm Drain (if required)	71.00	LF	\$ 50.00	\$ 3,550.00	71.00	\$ -	\$ -	71.00	\$ 3,550.00	-	\$ -	71.00	\$ 3,550.00	100%	0.00	\$ -		
Sod Pond Slopes	14,400.00	SY	\$ 4.70	\$ 67,680.00	14,400.00	\$ -	\$ -	14,400.00	\$ 67,680.00	-	\$ -	14,400.00	\$ 67,680.00	100%	0.00	\$ -		
Survey, Test, As Built, MOB	1.00	LS	\$ 21,300.00	\$ 21,300.00	1.00	\$ -	\$ -	1.00	\$ 21,300.00	-	\$ -	1.00	\$ 21,300.00	100%	0.00	\$ -		
Roadway Fill	(41,000.00)	CY	\$ 24.00	\$ (984,000.00)	(41,000.00)	\$ -	\$ -	(41,000.00)	\$ (984,000.00)	-	\$ -	(41,000.00)	\$ (984,000.00)	100%	0.00	\$ -		
Lot Fill	(51,000.00)	CY	\$ 24.00	\$ (1,224,000.00)	(51,000.00)	\$ -	\$ -	(51,000.00)	\$ (1,224,000.00)	-	\$ -	(51,000.00)	\$ (1,224,000.00)	100%	0.00	\$ -		
Fill from Rec Pond	92,000.00	CY	\$ 7.80	\$ 717,600.00	92,000.00	\$ -	\$ -	92,000.00	\$ 717,600.00	-	\$ -	92,000.00	\$ 717,600.00	100%	0.00	\$ -		
Change Order 9				\$ -				\$ -				\$ -				\$ -		
Trailmark Pothole Repairs	1.00	LS	\$ 1,500.00	\$ 1,500.00	1.00	\$ -	\$ -	1.00	\$ 1,500.00	-	\$ -	1.00	\$ 1,500.00	100%	0.00	\$ -		
Change Order 10				\$ -				\$ -				\$ -				\$ -		
NPDES & Erosion Control Mail Kiosk	1.00	LS	\$ 12,190.00	\$ 12,190.00	1.00	\$ -	\$ -	1.00	\$ 12,190.00	-	\$ -	1.00	\$ 12,190.00	100%	0.00	\$ -		
Demo & Earthwork	1.00	LS	\$ 22,000.00	\$ 22,000.00	1.00	\$ -	\$ -	1.00	\$ 22,000.00	-	\$ -	1.00	\$ 22,000.00	100%	0.00	\$ -		
Base and Paving	1.00	LS	\$ 54,780.00	\$ 54,780.00	1.00	\$ -	\$ -	1.00	\$ 54,780.00	-	\$ -	1.00	\$ 54,780.00	100%	0.00	\$ -		
Change Order 11				\$ -				\$ -				\$ -				\$ -		
Mob & Survey FPL Easement	1.00	LS	\$ 10,000.00	\$ 10,000.00	1.00	\$ -	\$ -	1.00	\$ 10,000.00	-	\$ -	1.00	\$ 10,000.00	100%	0.00	\$ -		
Erosion Control	1.00	LS	\$ 26,300.00	\$ 26,300.00	1.00	\$ -	\$ -	1.00	\$ 26,300.00	-	\$ -	1.00	\$ 26,300.00	100%	0.00	\$ -		
Earthwork	1.00	LS	\$ 26,300.00	\$ 26,300.00	1.00	\$ -	\$ -	1.00	\$ 26,300.00	-	\$ -	1.00	\$ 26,300.00	100%	0.00	\$ -		
Storm 15" RCP	1.00	LS	\$ 13,030.00	\$ 13,030.00	1.00	\$ -	\$ -	1.00	\$ 13,030.00	-	\$ -	1.00	\$ 13,030.00	100%	0.00	\$ -		
6" Roadway Base - Crushcrete	1.00	LS	\$ 21,120.00	\$ 21,120.00	1.00	\$ -	\$ -	1.00	\$ 21,120.00	-	\$ -	1.00	\$ 21,120.00	100%	0.00	\$ -		
Change Order 12				\$ -				\$ -				\$ -				\$ -		
MH-Adjustment	2.00	EA	\$ 750.00	\$ 1,500.00	2.00	\$ -	\$ -	2.00	\$ 1,500.00	-	\$ -	2.00	\$ 1,500.00	100%	0.00	\$ -		
Fill-Grade - Sod Amenities Center	1.00	LS	\$ 5,605.00	\$ 5,605.00	1.00	\$ -	\$ -	1.00	\$ 5,605.00	-	\$ -	1.00	\$ 5,605.00	100%	0.00	\$ -		
Change Order 13				\$ -				\$ -				\$ -				\$ -		
Mod. S-EX-305A Knockout	1.00	LS	\$ 4,300.00	\$ 4,300.00	1.00	\$ -	\$ -	1.00	\$ 4,300.00	-	\$ -	1.00	\$ 4,300.00	100%	0.00	\$ -		
Change Order 14				\$ -				\$ -				\$ -				\$ -		
Rain Dots	1.00		\$ -	\$ -	1.00	\$ -	\$ -	1.00	\$ -	-	\$ -	1.00	\$ -	#DIV/0!	0.00	\$ -		
Change Order 15				\$ -				\$ -				\$ -				\$ -		
FPL Easement Cert. As-Built	1.00		\$ 3,000.00	\$ 3,000.00	1.00	\$ -	\$ -	1.00	\$ 3,000.00	-	\$ -	1.00	\$ 3,000.00	100%	0.00	\$ -		
Change Order 16				\$ -				\$ -				\$ -				\$ -		
FPL PH-A w/ sleeves	1.00	LS	\$ 113,217.00	\$ 113,217.00	1.00	\$ -	\$ -	1.00	\$ 113,217.00	-	\$ -	1.00	\$ 113,217.00	100%	0.00	\$ -		
FPL PH-B w/ sleeves	1.00	LS	\$ 59,642.70	\$ 59,642.70	1.00	\$ -	\$ -	1.00	\$ 59,642.70	-	\$ -	1.00	\$ 59,642.70	100%	0.00	\$ -		
FPL PH-C w/ sleeves	1.00	LS	\$ 69,089.80	\$ 69,089.80	1.00	\$ -	\$ -	1.00	\$ 69,089.80	-	\$ -	1.00	\$ 69,089.80	100%	0.00	\$ -		
FPL Allowance per Contract	1.00	LS	\$ (175,000.00)	\$ (175,000.00)	1.00	\$ -	\$ -	1.00	\$ (175,000.00)	-	\$ -	1.00	\$ (175,000.00)	100%	0.00	\$ -		
Credit 2" Sleeves	(4,000.00)	LF	\$ 12.00	\$ (48,000.00)	(4,000.00)	\$ -	\$ -	(4,000.00)	\$ (48,000.00)	-	\$ -	(4,000.00)	\$ (48,000.00)	100%	0.00	\$ -		
Credit 3" Sleeves	(3,500.00)	LF	\$ 14.00	\$ (49,000.00)	(3,500.00)	\$ -	\$ -	(3,500.00)	\$ (49,000.00)	-	\$ -	(3,500.00)	\$ (49,000.00)	100%	0.00	\$ -		
Credit 4" Sleeves	(4,500.00)	LF	\$ 16.00	\$ (72,000.00)	(4,500.00)	\$ -	\$ -	(4,500.00)	\$ (72,000.00)	-	\$ -	(4,500.00)	\$ (72,000.00)	100%	0.00	\$ -		
Credit 6" Sleeves	(3,000.00)	LF	\$ 18.00	\$ (54,000.00)	(3,000.00)	\$ -	\$ -	(3,000.00)	\$ (54,000.00)	-	\$ -	(3,000.00)	\$ (54,000.00)	100%	0.00	\$ -		
Change Order 17 Cronin Utility				\$ -				\$ -				\$ -				\$ -		
Water	1.00	LS	\$ 32,736.00	\$ 32,736.00	1.00	\$ -	\$ -	1.00	\$ 32,736.00	-	\$ -	1.00	\$ 32,736.00	100%	0.00	\$ -		
Force Main	1.00	LS	\$ 17,580.00	\$ 17,580.00	1.00	\$ -	\$ -	1.00	\$ 17,580.00	-	\$ -	1.00	\$ 17,580.00	100%	0.00	\$ -		
Concrete	1.00	LS	\$ (3,650.00)	\$ (3,650.00)	1.00	\$ -	\$ -	1.00	\$ (3,650.00)	-	\$ -	1.00	\$ (3,650.00)	100%	0.00	\$ -		

Project Number: 22-2247
 Project Name: Trailmark 12
 Owner Name: ET&M
 Contract Number: 22-260
 For Month Ending: 11/25/2024

Period Ending: 11/25/24
 Variance: \$0.00
 Projected Final: \$10,932,860.62
 Billings To Date: \$10,932,860.62
 Remaining Billings: \$59,120.00

Bid Items	Original Contract Amt				Pror. Quantity	Current		Materials Amount	To Date		Remaining		Projected Final		N Complete	Projection vs. Original	
	Qty	UM	Unit Price	L&E Total Amount		Quantity	Amount		Quantity	Amount	Quantity	Amount	Quantity	Amount		Quantity	Amount
Roadway	1.000	LS	\$ 2,520.00	\$ 2,520.00	1.00		\$		1.00	\$ 2,520.00		\$	1.00	\$ 2,520.00	100%	0.000	\$
Survey & Testing	1.000	LS	\$ 3,720.00	\$ 3,720.00	1.00		\$		1.00	\$ 3,720.00		\$	1.00	\$ 3,720.00	100%	0.000	\$
Change Order 18 Outfall Regrade				\$			\$			\$		\$		\$			\$
Mobilization	1.000	LS	\$ 10,000.00	\$ 10,000.00	1.00		\$		1.00	\$ 10,000.00		\$	1.00	\$ 10,000.00	100%	0.000	\$
Erosion Control	1.000	LS	\$ 1,500.00	\$ 1,500.00	1.00		\$		1.00	\$ 1,500.00		\$	1.00	\$ 1,500.00	100%	0.000	\$
Grassing	1.000	LS	\$ 6,500.00	\$ 6,500.00	1.00		\$		1.00	\$ 6,500.00		\$	1.00	\$ 6,500.00	100%	0.000	\$
Regrade Dispersion Pond	1.000	LS	\$ 19,000.00	\$ 19,000.00	1.00		\$		1.00	\$ 19,000.00		\$	1.00	\$ 19,000.00	100%	0.000	\$
R&R Curb & Concrete	1.000	LS	\$ 5,200.00	\$ 5,200.00	1.00		\$		1.00	\$ 5,200.00		\$	1.00	\$ 5,200.00	100%	0.000	\$
MOT Credit	1.000	LS	\$ (5,110.00)	\$ (5,110.00)	1.00		\$		1.00	\$ (5,110.00)		\$	1.00	\$ (5,110.00)	100%	0.000	\$
Change Order 19 Teco Damg. 12A				\$			\$			\$		\$		\$	#DIV/0!	0.000	\$
Teco Damag Ph- 12A	1.000		\$ 2,800.00	\$ 2,800.00	1.00		\$		1.00	\$ 2,800.00		\$	1.00	\$ 2,800.00	100%	0.000	\$
Change Order 20 TM-11 Repairs				\$			\$			\$		\$		\$	#DIV/0!	0.000	\$
New Curb at 3 Temp Cul-De Sac's	408.000	LF	\$ 26.00	\$ 10,608.00	408.00		\$		408.00	\$ 10,608.00		\$	408.00	\$ 10,608.00	100%	0.000	\$
Repair Wash Out Pond 32 w/ Fill and Sod	1.000	LS	\$ 2,300.00	\$ 2,300.00	1.00		\$		1.00	\$ 2,300.00		\$	1.00	\$ 2,300.00	100%	0.000	\$
Change Order 21 Rec Pond B' Path				\$			\$			\$		\$		\$	#DIV/0!	0.000	\$
GRADE	1.000	LS	\$ 15,000.00	\$ 15,000.00			\$ 12,750.00		0.85	\$ 12,750.00		\$ 2,250.00	1.00	\$ 15,000.00	85%	0.000	\$
12" STABILIZE	2,600.000	SY	\$ 13.00	\$ 33,800.00			\$ 28,600.00		2,200.00	\$ 28,600.00		\$ 5,200.00	2,600.00	\$ 33,800.00	85%	0.000	\$
HC RAMP AT CUL DE SAC	1.000	LS	\$ 3,500.00	\$ 3,500.00			\$			\$		\$ 3,500.00	1.00	\$ 3,500.00	0%	0.000	\$
4" CRUSH	2,600.000	SY	\$ 19.50	\$ 50,700.00			\$ 42,900.00		2,200.00	\$ 42,900.00		\$ 7,800.00	2,600.00	\$ 50,700.00	85%	0.000	\$
SURVEY & AS BUILTS	1.000	LS	\$ 6,800.00	\$ 6,800.00			\$ 6,080.00		0.60	\$ 6,080.00		\$ 720.00	1.00	\$ 6,800.00	60%	0.000	\$
SOD AT TIE INS	750.000	SY	\$ 7.00	\$ 5,250.00			\$			\$		\$ 5,250.00	750.00	\$ 5,250.00	0%	0.000	\$
				\$			\$			\$		\$		\$	#DIV/0!	0.000	\$
				\$			\$			\$		\$		\$	#DIV/0!	0.000	\$
Change Order Total:				\$ (500,653.00)			\$ 600,100.00			\$ 1,100,750.00		\$ 499,120.00		\$ (500,653.00)			\$

Project Number: 22-2247
 Project Name: Trailmark 12
 Owner Name: ET&M
 Contract Number: 22-260
 For Month Ending: 11/25/2024

Period Ending: 11/25/24
 Variance: \$0.00
 Projected Final: \$10,991,960.62
 Billings To Date: \$10,932,840.62
 Remaining Billing: \$59,120.00

Bid Items	Original Contract Amt				Prev. Quantity	Current		Materials Amount	To Date		Remaining		Projected Final		% Complete	Projection vs. Original	
	Qty	UM	Unit Price	L&E Total Amount		Quantity	Amount		Quantity	Amount	Quantity	Amount	Quantity	Amount		Quantity	Amount
				\$9,581,895.89		\$92,730.00	\$1,410,064.73		\$10,932,840.62		\$59,120.00		\$10,991,960.62				

Total Contract w/ Materials: \$10,991,960.62

All Change Orders w/ Materials: -560,655.38

	\$ 9,451,137.89	\$ 31,848.00	\$ 1,410,064.73	\$ 10,763,270.62	\$ 728,690.00	\$ 10,991,960.62
Total Contract w/ Materials	\$10,861,202.62					

PARTIAL RELEASE OF CLAIM OF LIEN

The undersigned lienor, in consideration of payment in the amount of \$ 88,093.00, hereby partially releases its claim of lien for labor, services, or materials furnished to Six Mile Creek CDD, on the job of Trailmark PH 12, for the following described property:
Trailmark Phase 12

The undersigned lienor acknowledges previous receipt of \$10,298,105.09 and is executing this waiver and release in exchange for a check or checks in the additional amount of \$88,093.00, this partial release of claim of lien expressly and totally is conditioned on receipt of the check or checks and the collection of the funds in the amount of \$88,093.00

There remains unpaid \$ 693,855.53.

Dated: November 25, 20 24

Signed and sealed in the presence of:

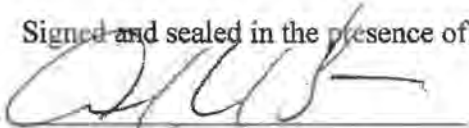

Witness



Lienor

STATE OF FLORIDA
COUNTY OF Duval

I HEREBY CERTIFY that on this day, November 25, 2024 before me, an officer duly authorized in the State aforesaid and in the County aforesaid to take acknowledgments, personally appeared Charles D. Freshwater, as President of Jax Utilities Management, Inc. a Florida corporation, on behalf of the corporation, and she/he acknowledged before me that she/he executed the same and did so by order of the Board of Directors of the Corporation.

He/She is personally known to me [] produced N/A as identification []

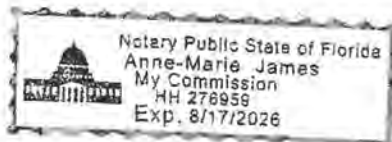

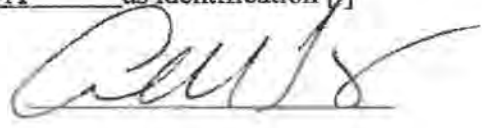

Notary Public

REQUISITION NO. 91

**SIX MILE CREEK COMMUNITY DEVELOPMENT DISTRICT
(ST. JOHNS COUNTY, FLORIDA)**

\$2,640,000

**CAPITAL IMPROVEMENT REVENUE BOND
SERIES 2021(AA3, Phase 2)**

The undersigned, a Responsible Officer of Six Mile Creek Community Development District (the "District") hereby submits the following requisition for disbursement under and pursuant to the terms of the Master Trust Indenture from the District to U. S. Bank National Association, as trustee (the "Trustee"), dated as of July 1, 2007, as supplemented by a Tenth Supplemental Trust Indenture, dated as of November 1, 2021 (collectively, the "Indenture"; all capitalized terms used herein shall have the meaning ascribed to such term in the Indenture):

- (A) Requisition Number: 91

- (B) Name of Payee: Kutak Rock, LLP
ABA#
First National Bank of Omaha
A/C #

- (C) Amount Payable: Total: \$ 188.00

- (D) Purpose for which paid or incurred (refer also to specific contract if amount is due and payable pursuant to a contract involving progress payments, or, state Costs of Issuance, if applicable): Professional services related to project construction – Invoice 3480055 (August 2024)

- (E) Fund or Account from which disbursement to be made:

Capital Improvement Revenue Bond Series 2021(Assessment Area 3, Phase 2)

The undersigned hereby certifies that:

1. obligations in the stated amount set forth above have been incurred by the District,
2. each disbursement set forth above is a proper charge against the Phase 1 Acquisition and Construction Account;
3. each disbursement set forth above was incurred in connection with the acquisition and/or construction of the Project;
4. each disbursement represents a Cost of the Project which has not previously been paid.

The undersigned hereby further certifies that there has not been filed with or served upon the District notice of any lien, right to lien, or attachment upon, or claim affecting the right to receive payment of, any of the moneys payable to the Payee set forth above, which has not been released or will not be released simultaneously with the payment hereof.

The undersigned hereby further certifies that such requisition contains no item representing payment on account of any retained percentage which the District is at the date of such certificate entitled to retain.

Attached hereto are originals of the invoice(s) from the vendor of the property acquired or the services rendered with respect to which disbursement is hereby requested.

**SIX MILE CREEK COMMUNITY
DEVELOPMENT DISTRICT**

By: _____

Chairperson, Board of Supervisors

CONSULTING ENGINEER'S APPROVAL

The undersigned Consulting Engineer hereby certifies that this disbursement is for a Cost of the Project and is consistent with: (i) the applicable acquisition or construction contract; (ii) the plans and specifications for the portion of the Project with respect to which such disbursement is being made; and (iii) the report of the Consulting Engineer, as such report shall have been amended or modified on the date hereof.

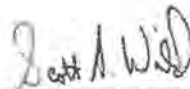

Consulting Engineer

KUTAK ROCK LLP

TALLAHASSEE, FLORIDA

Telephone 404-222-4600

Facsimile 404-222-4654

Federal ID 47-0597598

November 6, 2024

Check Remit To:

Kutak Rock LLP

PO Box 30057

Omaha, NE 68103-1157

ACH/Wire Transfer Remit To:

ABA #

First National Bank of Omaha

Kutak Rock LLP

A/C #

Reference: Invoice No. 3480055

Client Matter No. 18323-2

Notification Email: eftgroup@kutakrock.com

Six Mile Creek CDD
Governmental Management Services – St. Augustine
Suite 114
475 West Town Place
St. Augustine, FL 32092

Invoice No. 3480055
18323-2

Re: Six Mile Creek CDD - Project Construction

For Professional Legal Services Rendered

08/06/24	W. Haber	0.40	94.00	Prepare landscape installation agreement for Phase 10; confer with McKenna regarding same
08/22/24	W. Haber	0.40	94.00	Review and revise agreement for mitigation services

TOTAL HOURS 0.80

TOTAL FOR SERVICES RENDERED \$188.00

TOTAL CURRENT AMOUNT DUE \$188.00

REQUISITION NO. 92

**SIX MILE CREEK COMMUNITY DEVELOPMENT DISTRICT
(ST. JOHNS COUNTY, FLORIDA)**

\$2,640,000

**CAPITAL IMPROVEMENT REVENUE BOND
SERIES 2021(AA3, Phase 2)**

The undersigned, a Responsible Officer of Six Mile Creek Community Development District (the "District") hereby submits the following requisition for disbursement under and pursuant to the terms of the Master Trust Indenture from the District to U. S. Bank National Association, as trustee (the "Trustee"), dated as of July 1, 2007, as supplemented by a Tenth Supplemental Trust Indenture, dated as of November 1, 2021 (collectively, the "Indenture"; all capitalized terms used herein shall have the meaning ascribed to such term in the Indenture):

- (A) Requisition Number: 92

- (B) Name of Payee: Kutak Rock,
LLP ABA#
First National Bank of Omaha
A/C #

- (C) Amount Payable: Total: \$ 352.50

- (D) Purpose for which paid or incurred (refer also to specific contract if amount is due and payable pursuant to a contract involving progress payments, or, state Costs of Issuance, if applicable): Professional services related to project construction – Invoice 3496010-18323-2 (September 2024)

- (E) Fund or Account from which disbursement to be made:

Capital Improvement Revenue Bond Series 2021(Assessment Area 3, Phase 2)

The undersigned hereby certifies that:

1. obligations in the stated amount set forth above have been incurred by the District,
2. each disbursement set forth above is a proper charge against the Phase 1 Acquisition and Construction Account;
3. each disbursement set forth above was incurred in connection with the acquisition and/or construction of the Project;
4. each disbursement represents a Cost of the Project which has not previously been paid.

The undersigned hereby further certifies that there has not been filed with or served upon the District notice of any lien, right to lien, or attachment upon, or claim affecting the right to receive payment of, any of the moneys payable to the Payee set forth above, which has not been released or will not be released simultaneously with the payment hereof.

The undersigned hereby further certifies that such requisition contains no item representing payment on account of any retained percentage which the District is at the date of such certificate entitled to retain.

Attached hereto are originals of the invoice(s) from the vendor of the property acquired or the services rendered with respect to which disbursement is hereby requested.

**SIX MILE CREEK COMMUNITY
DEVELOPMENT DISTRICT**

By: _____

Chairperson, Board of Supervisors

CONSULTING ENGINEER'S APPROVAL

The undersigned Consulting Engineer hereby certifies that this disbursement is for a Cost of the Project and is consistent with: (i) the applicable acquisition or construction contract; (ii) the plans and specifications for the portion of the Project with respect to which such disbursement is being made; and (iii) the report of the Consulting Engineer, as such report shall have been amended or modified on the date hereof.

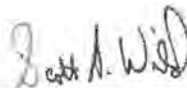

Consulting Engineer

KUTAK ROCK LLP

TALLAHASSEE, FLORIDA

Telephone 404-222-4600

Facsimile 404-222-4654

Federal ID 47-0597598

December 5, 2024

Check Remit To:

Kutak Rock LLP

PO Box 30057

Omaha, NE 68103-1157

ACH/Wire Transfer Remit To:

ABA #

First National Bank of Omaha

Kutak Rock LLP

A/C #

Reference: Invoice No. 3496010

Client Matter No. 18323-2

Notification Email: eftgroup@kutakrock.com

Six Mile Creek CDD
Governmental Management Services – St. Augustine
Suite 114
475 West Town Place
St. Augustine, FL 32092

Invoice No. 3496010
18323-2

Re: Six Mile Creek CDD - Project Construction

For Professional Legal Services Rendered

09/02/24	W. Haber	0.30	70.50	Review and respond to correspondence regarding reimbursement from TECO for damage to CDD property
09/04/24	W. Haber	0.30	70.50	Prepare agreement for landscape installation
09/10/24	W. Haber	0.20	47.00	Review license agreement for recreation pond
09/16/24	W. Haber	0.50	117.50	Prepare correspondence regarding reimbursement for work damaged by TECO
09/30/24	W. Haber	0.20	47.00	Confer with Cornelison regarding status of alleyway paving agreement

TOTAL HOURS 1.50

TOTAL FOR SERVICES RENDERED \$352.50

TOTAL CURRENT AMOUNT DUE \$352.50

INVOICE

FSJ Pool Services, LLC. dba
America's Swimming Pool Co. of St.
Augustine
52 Tuscan Way Suite 202 Box # 243
St. Augustine, FL 32092

staugustine@asppoolco.com
904-788-3111
www.asppoolco.com/st-augustine/



Six Mile Creek- Reverie
Bill to
Six Mile Creek CDD
6200 Lee Blvd Suite 300
Orlando, FL 32822

#18
002-340-53800-46501
Received: 12/18/24
Approved: Matthew Reid CAM

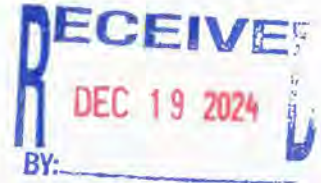

Invoice details

Invoice no.: 6320
Terms: Due on receipt
Invoice date: 12/17/2024
Due date: 12/31/2024

#	Date	Product or service	Description	Qty	Rate	Amount
1.	12/03/2024	Services	Spa/Resort/Lap pools- Replace six new probes: 3 PH probes and 3 ORP probes- installed. Two probes per pool.	1	\$1,932.84	\$1,932.84

Total \$1,932.84

Ways to pay



To pay by check please mail to:
52 Tuscan Way Suite 202 #243
St Augustine, FL 32092

[View and pay](#)

View invoice online

Scan code or go to the link below to view the invoice online
[View invoice](#)

FSJ Pool Services, LLC. dba America's Swimming Pool Co. of St. Augustine
52 Tuscan Way Suite 202 Box # 243
St. Augustine, FL 32092
904-788-3111
staugustine@asppoolco.com
www.asppoolco.com/st-augustine/



904-788-3111 CPC# 1459854
MAINTENANCE REPAIRS RENOVATIONS

BILL TO
Six Mile Creek - Reverie
6200 Lee Vista Boulevard
Suite 300
Orlando, FL 32801

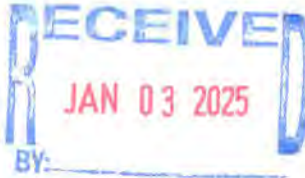

INVOICE 6334

DATE 01/01/2025 **TERMS** Net 10

DATE	ACTIVITY	DESCRIPTION	AMOUNT
	MAINTENANCE	Swimming Pool Maintenance	2,060.00

TOTAL DUE \$2,060.00

#18
002-340-53800-46500
Received: 1/1/25
Approved: Matthew Reid CAM

Dynamic Security Professionals, Inc.

Invoice

P.O. Box 23861
Jacksonville, FL 32241
EF0001108

#16
002-340-53800-46000
Received: 12/23/24
Approved: Matthew Reid CAM

Date	Invoice #
12/23/2024	45042

Bill To
Six Mile Creek Amenity CDD 475 West Town Place #114 St. Augustine, FL 32092

Location
Reverie 35 Rustic Mill Drive St. Augustine, FL 32092

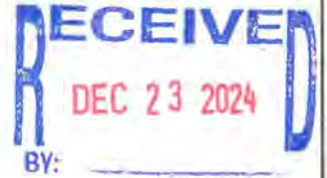

P.O. No.	Terms
	Due on receipt

Quantity	Description	Rate	Amount
3	Quarterly Monitoring of Fire Alarm System Via Starlink Cellular for 1st Quarter	75.00	225.00

Thank you for your business.	Subtotal	\$225.00
	Sales Tax (6.5%)	\$0.00
	Total	\$225.00
	Payments/Credits	\$0.00
	Balance Due	\$225.00

Envera
 8281 Blaikie Court
 Sarasota, FL 34240
 (941) 556-7066

Invoice	
Invoice Number 748838	Date 12/02/2024
Customer Number 300389	Due Date 01/01/2025

Page 1

Customer Name	Customer Number	P.O. Number	Invoice Number	Due Date
Six Mile Creek CDD-The Reverie	300389		748838	01/01/2025
Quantity	Description	Rate	Amount	
<i>Six Mile Creek CDD-The Reverie, Entrance, Pacetti Rd, Saint Augustine, FL</i>				
1.00	Service & Maintenance 01/01/2025 - 01/31/2025	321.62	321.62	
1.00	Virtual Gate Guard Monitoring 01/01/2025 - 01/31/2025	2,650.00	2,650.00	
1.00	Service & Maintenance 01/01/2025 - 01/31/2025	8.99	8.99	
1.00	Envera Kiosk System 01/01/2025 - 01/31/2025	500.00	500.00	
1.00	Data Management 01/01/2025 - 01/31/2025	200.00	200.00	
	Sales Tax			0.00
	Payments/Credits Applied			0.00
			Invoice Balance Due:	\$3,680.61

RECEIVED
 DEC 04 2024
 BY: _____

IMPORTANT MESSAGES

Important Numbers to Know:

Billing Questions: (941) 556-7066
 Email: ar@enverasystems.com
 Service: (941) 952-3719

#4
 002-340-53800-34500
 Received: 12/16/24
 Approved: Matthew Reid CAM

RECEIVED
 JAN 03 2025
 BY: _____

Date	Invoice #	Description	Amount	Balance Due
12/02/2024	748838	Monitoring Services	\$3,680.61	\$3,680.61

Envera
 8281 Blaikie Court
 Sarasota, FL 34240
 (941) 556-7066

Return Service Requested

Invoice	
Invoice Number 748838	Date 12/02/2024
Customer Number 300389	Due Date 01/01/2025

Net Due: \$3,680.61

Amount Enclosed: \$ 3680.61

 SIX MILE CREEK CDD-THE REVERIE
 6200 LEE VISTA BLVD STE 300
 ORLANDO, FL 32822-5149

2452

REMIT TO:
 Envera
 PO Box 2086
 Hicksville, NY 11802



Page	1/1
Date	12/11/2024
Reference	
Invoice Number	INV000008078

Hidden Eyes LLC
d/b/a Envera Systems
 P.O. Box 2086
 Hicksville, NY 11802
 (941) 556-0743

#4
 002-340-53800-34500
 Received: 1/3/25
 Matthew Reid CAM

RECEIVED
 JAN 03 2025
 BY:

Bill To
 Six Mile Creek CDD
 6200 Lee Vista Blvd., Suite 300
 Orlando, FL, 32822

Site
 Six Mile Creek CDD - Gate
 Pacetti Rd.
 St. Augustine, FL, 32092

Bill To Number	Document Number	Type	Site Number	Entered By	Customer Reference	Weight
002667	ORD000000520	SER	002667G	NGSANTO		0.0000

Code / Description	Supply	Unit	Unit Price	Discount	Unit Tax	Ext.
17-AWI-0010 34 BIT HSF FOB	100.00		11.00	1.10	0.00	990.00
CRED-SHIP Shipping Charge - Credentials	1	EA	15.00	0.00	0.00	15.00

If terms permit, where paying by check
 Please make payable to Envera Systems
 Remit to: P.O. Box 2086 Hicksville, NY 11802

Tax Summary
 FL 0.00

Services	15.00
Items	1,100.00
Subtotal	1,115.00
Less Discount	110.00
Less Cover	0.00
Plus Excl. Tax	0.00
Less Payment	
Total Due (USD)	1,005.00

Due Date: 1/10/2025

Terms: Net 30 Days



Hawkins, Inc.
2381 Rosegate
Roseville, MN 55113
Phone: (612) 331-6910

INVOICE

Total Invoice **\$870.00**
 Invoice Number **6951189**
 Invoice Date **1/2/25**
 Sales Order Number/Type **4702670 SL**
 Branch Plant **74**
 Shipment Number **5616019**

Sold To: **484851**
ACCOUNTS PAYABLE
SIX MILE CREEK CDD
6200 Lee Vista Blvd
Ste 300
Orlando FL 32822

Ship To: **484858**
SIX MILE CREEK CDD EAST PARCEL
REVERIE
85 Rustic Mill Dr
St Augustine FL 32092-7940

Net Due Date	Terms	FOB Description	Ship Via	Customer P.O.#	P.O. Release	Sales Agent #			
2/1/25	Net 30	PPD Origin	HWTG			381			
Line #	Item Number	Item Name/ Description	Tax	Qty Shipped	Trans UOM	Unit Price	Price UOM	Weight Net/Gross	Extended Price
1.000	41930	Azone - EPA Reg. No. 7870-1 1 LB BLK (Mini-Bulk)	N	330.0000 330.0000	GA GA	\$2.6000	GA	3,191.1 LB 3,191.1 GW	\$858.00
1.010	Fuel Surcharge	Freight	N	1.0000	EA	\$12.0000			\$12.00

***** Receive Your Invoice Via Email *****

Please contact our Accounts Receivable Department via email at Credit.Dept@HawkinsInc.com or call 612-331-6910 to get it setup on your account.

#17
 002-340-53800-46500
 Received: 1/3/25
 Approved: Matthew Reid CAM



Tax Rate **0 %**
 Sales Tax **\$0.00**

Invoice Total \$870.00

No Discounts on Freight
IMPORTANT: All products are sold without warranty of any kind and purchasers will, by their own tests, determine suitability of such products for their own use. Seller warrants that all goods covered by this invoice were produced in compliance with the requirements of the Fair Labor Standards Act of 1938, as amended. Seller specifically disclaims and excludes any warranty of merchantability and any warranty of fitness for a particular purpose.
NO CLAIMS FOR LOSS, DAMAGE OR LEAKAGE ALLOWED AFTER DELIVERY IS MADE IN GOOD CONDITION.

CHECK REMITTANCE:
 Hawkins, Inc.
 P.O. Box 860263
 Minneapolis, MN 55486-0263

WIRING CONTACT INFORMATION:
 Email: Credit.Dept@Hawkinsinc.com
 Phone Number: (612) 331-6910
 Fax Number: (612) 225-6702

FINANCIAL INSTITUTION:
 US Bank
 800 Nicollet Mall
 Minneapolis, MN 55402

Account Name: Hawkins, Inc.
 Account #: 180120759469
 ABA/Routing #: 091000022
 Swift Code#: USBKUS44IMT
 Type of Account: Corporate Checking

ACH PAYMENTS:
 CTX (Corporate Trade Exchange) is our preferred method. Please remember to include in the addendum the document numbers pertaining to the payment.
 For other than CTX, the remit to information may be emailed to Credit.Dept@Hawkinsinc.com

CASH IN ADVANCE/EFT PAYMENTS:
 Please list the Hawkins, Inc. sales order number or your purchase order number if the invoice has not been processed yet.



Remit To:
 JANI-KING OF JACKSONVILLE
 5700 ST. AUGUSTINE ROAD
 JACKSONVILLE FL 32207
 (904) 346-3000

Invoice	
Date 01/01/2025	Number JAK01250240
Due Date 01/31/2025	Cust # 480046
Invoice Amount \$ 1,399.89	Amount Remitted \$1399.89

Sold To:
 SIX MILE CREEK CDD
 6200 LEE VISTA BLVD
 STE 300
 ORLANDO FL 32801

#50
 002-340-53800-46700
 Received: 12/30/24
 Approved: Matthew Reid CAM

For:
 THE REVERIE AT TRAILMARK
 35 RUSTIC MILL DR
 ST AUGUSTINE FL 32092

Make All Checks Payable To: JANI-KING OF JACKSONVILLE
 RETURN THIS PORTION WITH YOUR PAYMENT

JANI-KING OF JACKSONVILLE
 Commercial Cleaning Services
 (904) 346-3000



Sold To:
 SIX MILE CREEK CDD
 6200 LEE VISTA BLVD
 STE 300
 ORLANDO FL 32801

For:
 THE REVERIE AT TRAILMARK
 35 RUSTIC MILL DR
 ST AUGUSTINE FL 32092

Invoice No	Date	Cust No	Slsmn No	PO Number	Franchisee	Due Date
JAK01250240	01/01/2025	480046	MINI PEREZ		PRO-FRESH TEAM, INC	01/31/2025
Quantity	Description				Unit Price	Extended Price
1	MONTHLY CONTRACT BILLING AMOUNT FOR JANUARY				1399.89	1399.89
Make All Checks Payable To: JANI-KING OF JACKSONVILLE					Amount of Sale	\$ 1,399.89
					Sales Tax	\$ 0.00
					Total	\$ 1,399.89



INVOICE

M&G Holiday Lighting
52 Tuscan Way Ste 202-349
Saint Augustine, FL 32092

holidayandeventlights@gmail.com
+1 (904) 679-1150



Bill to
Six Mile Creek CDD / Reverie
35 Rustic Mill Dr.
St. Augustine, FL 32092

#10
002-340-53800-47300
Received: 12/30/24
Approved: Matthew Reid CAM



Invoice details

Invoice no.: 1060
Terms: Net 30
Invoice date: 12/27/2024
Due date: 01/26/2025

#	Date	Product or service	Description	Qty	Rate	Amount
1.		Holiday Lighting Reinstall	Outline lower, mid and top column sign of community monument in C7 Warm White (WW)	1	\$621.00	\$621.00
2.		Holiday Lighting Reinstall	Outline sign peaks at fascia in C& WW	1	\$292.50	\$292.50
3.		Holiday Lighting Reinstall	Reinstall to mid column 4, 48" pre-lit wreaths with traditional red velvet bows, two facing in and the two facing out	1	\$330.56	\$330.56
4.		Holiday Lighting Reinstall	Reinstall C7WW to top of neighborhood sign	1	\$45.00	\$45.00
5.		Holiday Lighting Reinstall	Median- reinstall 2, 48" pre-lit wreaths with traditional red velvet bows to columns facing the entrance of the neighborhood	1	\$165.28	\$165.28
6.		Holiday Lighting Reinstall	Line the fronts of the column caps with C7 WW lights	1	\$90.00	\$90.00
7.		Holiday Lighting Reinstall	Reinstall 3, 5' WW LED snowflakes on post	1	\$450.00	\$450.00
8.		Holiday Lighting Reinstall	Reinstall pre-lit garland to top of wood fence with medium drape and traditional red velvet bow on center	1	\$307.63	\$307.63

	Holiday Lighting Reinstall	Clubhouse - reinstall C7 WW to fascia, roofline and gutter of clubhouse building facing the entrance/parking lot	1	\$2,595.00	\$2,595.00
10.	Miscellaneous Wire, Plugs, Supplies, Etc	Misc supplies required for installation	1	\$175.00	\$175.00
11.	Equipment Charge	Boom rental for installation and take down	1	\$625.00	\$625.00
12.	Take Down	Take down of lights and decor and the end of the season	1	\$555.00	\$555.00
13.	Storage	Storage of lights and decor until following season	1	\$175.00	\$175.00

Total

\$6,426.97

Ways to pay



View and pay

View invoice online

Scan code or go to the link below to view the invoice online
[View invoice](#)



Service Slip/Invoice



MCCALL SERVICE
 PO BOX 600730
 JACKSONVILLE, FL 32260-0730
 800-342-6948

INVOICE:	59393820
DATE:	11/11/2024
ORDER:	59393820

Bill To: [77002840]
 SIX MILE CREEK EAST PARCEL
 35 RUSTIC MILL DR
 ST. AUGUSTINE, FL 32092-7940

#22
 002-340-53800-46800
 Received: 12/17/24
 Approved: Matthew Reid

Work Location: [77002840] 904-504-5882
 SIX MILE CREEK EAST PARCEL
 35 RUSTIC MILL DR
 ST AUGUSTINE, FL 32092

Work Date	Time	Target Pest	Technician	Time In
11/11/2024	10:53 AM		ADDOYLE	10:53 AM
Purchase Order	Terms	Last Service	Map Code	Time Out
	NET 30	11/11/2024		12:03 PM

Service	Description	Price
---------	-------------	-------

FL COMM PM	FL COMMERCIAL PEST MGMT	\$75.00
------------	-------------------------	---------

It was a pleasure speaking with you today! I inspected and treated the exterior of the building. I applied a liquid residual to exterior structure. I applied a granular insect bait to exterior planter beds and removed webs and wasp nests from the building. Please note you may see activity after service, allow 3-5 days for treatment to thoroughly activate. If you have any questions or concerns please call us. Thank you for choosing McCall Service!
 Aaron Doyle

SUBTOTAL	\$75.00
TAX	\$0.00
AMT. PAID	\$0.00
TOTAL	\$75.00

AMOUNT DUE \$75.00

RECEIVED
 DEC 17 2024
 BY:

AD

TECHNICIAN SIGNATURE

CUSTOMER SIGNATURE

Balance outstanding over 30 days from the date of service may be subject to a late fee of the lesser of 1.5% per month, 18% per year or the maximum allowed by law. Customer agrees to pay accrued expenses in the event of collection.

Company assumes no liability for damages, completion, or service results, and accepts no responsibility for any consequential damages.



MCCALL SERVICE
 PO BOX 600730
 JACKSONVILLE, FL 32260-0730
 800-342-6948

Service Invoice / Inspection Report

ORDER #: 59406313

WORK DATE: 12/31/2024

BILL-TO 77002840

LOCATION 77002840

SIX MILE CREEK EAST PARCEL
 35 RUSTIC MILL DR
 ST. AUGUSTINE, FL 32092-7940

SIX MILE CREEK EAST PARCEL
 35 RUSTIC MILL DR
 ST AUGUSTINE, FL 32092

Time In: 12/31/2024 09:06:08 AM
Time Out: 12/31/2024 09:32:18 AM

Customer Signature

Phone: 904-504-5882 xMATT
 Alt. Phone: 904-504-5882 xREID

Phone: 904-504-5882 xMATT
 Alt. Phone: 904-504-5882 xREID

Customer Unavailable to Sign
Technician Signature

Ashley Gay
License #: FL - JE334676

Purchase Order	Terms	Service Description	Quantity	Amount
None	NET 30	FL COMMERCIAL PEST MGMT	1.00	75.00
				Subtotal 75.00
				Tax 0.00
Total Due:				75.00

#22
 002-340-53800-46800
 Received: 1/2/25
 Approved: Matthew Reid CAM

GENERAL COMMENTS / INSTRUCTIONS

Good morning
 I checked in with staff prior to starting service.
 Staff reported ants and ant hills on the exterior.
 I applied a liquid residual to interior entryways. I applied a gel bait to plumbing voids. I applied a dust product to wall voids and windowsills.
 I removed web build up and wasp nest from the exterior and applied a granular bait around ornamental areas of exterior. We could not apply a liquid to the exterior today due to the heavy rain.
 If you have any questions please contact us. Thank you for choosing McCall services.

CONDITIONS / OBSERVATIONS	Reported	Severity	Responsibility	Reviewed
None Noted.				

PRODUCTS APPLICATION SUMMARY

Material	Lot #	EPA #	A.I. %	A.I. Conc.	Active Ingredient	Finished Qty	Undiluted Qty
ALPINE WSG	23027k17ap	499-561	40.0000%	0.2000	DINOTEFURAN	10.0000 Ounce	1.5624 GRAMS
Areas Applied: Interior - Zone 1							
Target Pests: INTERIOR ANT							
INSECT TRAP - MON 100I		N/A	0.0000%	n/a	N/A	3.0000 Each	
ADHESIVE DEVICE							
Areas Applied: Interior - Zone 1							
Target Pests: (None)							
INTICE 10	ITP8040115	73079-6	10.0000%	n/a	Orthoboric Acid	2.0000 Pound	
Areas Applied: Immediate Ornamental Bed - Zone 4							
Target Pests: EXTERIOR ANT							
Material	Lot #	EPA #	A.I. %	A.I. Conc.	Active Ingredient	Finished Qty	Undiluted Qty

Starting Jan 1, 2024, you may see a slight increase in your billed amount due to increased operating costs.

GEORGIA CUSTOMERS ONLY: Contact Treated Area(s) - Don't allow unprotected persons, children, or pets to touch, enter, or replace items or bedding, to contact or enter treated area(s) until dry 2. Ventilation/Reoccupying-Vacate and keep area(s) closed up to 30 minutes after treatment, then ventilate area(s) for up to 2 hours before reoccupying 3. Equipment/Processing/Food - Thoroughly wash dishes, utensils, food preparation/processing equipment and surfaces with an effective cleaning compound and rinse with clean water, if not removed or covered during a treatment. The area should be odor free before food products are placed in the area 4. Exterior Applications (baits)-Don't allow grazing of feed, lawn, or sod clippings to livestock after bait applications 5. Don't burn treated firewood for 1 month after treatment.



MCCALL SERVICE
 PO BOX 600730
 JACKSONVILLE, FL 32260-0730
 800-342-6948

Service Invoice / Inspection Report

ORDER #: 59406313

WORK DATE: 12/31/2024

PRODUCTS APPLICATION SUMMARY

Material	Lot #	EPA #	A.I. %	A.I. Conc.	Active Ingredient	Finished Qty	Undiluted Qty
MAXFORCE FC MAGNUM ROACH KILLER BAIT GEL	nto4px0210	432-1460	0.0500%	n/a	FIPRONIL	6.0000 GRAMS	6.0000 GRAMS

Areas Applied: Interior - Zone 1
Target Pests: INTERIOR ROACHES

PEST ACTIVITY # Areas # Devices Pest Totals

None Noted.

DEVICE INSPECTION SUMMARY

AREA COMMENTS

None Noted.

DEVICE INSPECTION EXCEPTIONS

None Noted.

INSPECTION DETAIL

Area	Time	Type	Status	Pest Findings
Immediate Lower Exterior - Zone 2	9:06:41 AM	Area	No Activity	
Immediate Ornamental Bed - Zone 4	9:06:52 AM	Area	No Activity	
Immediate Upper Exterior - Zone 3	9:07:02 AM	Area	No Activity	
Interior - Zone 1	9:07:03 AM	Area	No Activity	

PRODUCTS APPLIED

Material	A.I. %	Finished Qty	Application Equipment	Application Rate	Time
EPA #	A.I. Concentration	Undiluted Qty	Application Method	Sq/Cu/L Ft	Lot #
INTICE 10	10.0000%	2.0000 Pound			9:07:00 AM
73079-6	n/a		BROADCAST		ITPB040115127

Target Pests: EXTERIOR ANT
Areas Applied: Immediate Ornamental Bed - Zone 4 - IOB - Zone 4;

ALPINE WSG	40.0000%	10.0000 Ounce			9:07:11 AM
499-561	0.20000000	1.5624 GRAMS	SPOT TREATMENT		23027k17ap

Target Pests: INTERIOR ANT

Starting Jan 1, 2024, you may see a slight increase in your billed amount due to increased operating costs.

GEORGIA CUSTOMERS ONLY: Contact Treated Area(s) - Don't allow unprotected persons, children, or pets to touch, enter, or replace items or bedding, to contact or enter treated area(s) until dry 2. Ventilation/Reoccupying-Vacate and keep area(s) closed up to 30 minutes after treatment, then ventilate area(s) for up to 2 hours before reoccupying 3. Equipment/Processing/Food - Thoroughly wash dishes, utensils, food preparation/processing equipment and surfaces with an effective cleaning compound and rinse with clean water, if not removed or covered during a treatment. The area should be odor free before food products are placed in the area 4. Exterior Applications (baits)-Don't allow grazing of feed, lawn, or sod clippings to livestock after bait applications 5. Don't burn treated firewood for 1 month after treatment.



MCCALL SERVICE
 PO BOX 600730
 JACKSONVILLE, FL 32260-0730
 800-342-6948

Service Invoice / Inspection Report

ORDER #: 59406313

WORK DATE: 12/31/2024

PRODUCTS APPLIED

Material	A.I. %	Finished Qty	Application Equipment	Application Rate	Time
EPA #	A.I. Concentration	Undiluted Qty	Application Method	Sq/Cu/L Ft	Lot #

Areas Applied: Interior - Zone 1 - Interior;

INSECT TRAP - MON 1001 ADHESIVE DEVICE	0.0000%	3.0000 Each			9:07:25 AM
--	---------	-------------	--	--	------------

N/A	n/a		PLACEMENT		
-----	-----	--	-----------	--	--

Areas Applied: Interior - Zone 1 - Interior;

MAXFORCE FC MAGNUM ROACH KILLER BAIT GEL	0.0500%	6.0000 GRAMS			9:07:17 AM
--	---------	--------------	--	--	------------

432-1460	n/a	6.0000 GRAMS	CRACK & CREVICE		nto4px0210
----------	-----	--------------	-----------------	--	------------

Target Pests: INTERIOR ROACHES

Areas Applied: Interior - Zone 1 - Interior;

Starting Jan 1, 2024, you may see a slight increase in your billed amount due to increased operating costs.

GEORGIA CUSTOMERS ONLY: Contact Treated Area(s) - Don't allow unprotected persons, children, or pets to touch, enter, or replace items or bedding, to contact or enter treated area(s) until dry 2. Ventilation/Reoccupying-Vacate and keep area(s) closed up to 30 minutes after treatment, then ventilate area(s) for up to 2 hours before reoccupying 3. Equipment/Processing/Food - Thoroughly wash dishes, utensils, food preparation/processing equipment and surfaces with an effective cleaning compound and rinse with clean water, if not removed or covered during a treatment. The area should be odor free before food products are placed in the area 4. Exterior Applications (baits)-Don't allow grazing of feed, lawn, or sod clippings to livestock after bait applications 5. Don't burn treated firewood for 1 month after treatment.

Reverie at Trailmark

INVOICE

Homeowners Association, Inc.

c/o FS Residential
1601 SW 80th Terrace
Plantation, FL 33324

DATE: December 31, 2024
INVOICE # 1241PR-3

Bill To:

Six Mile Creek Community Development District
475 West Town Place, Suite 114
St. Augustine, FL 32092



DESCRIPTION	AMOUNT
<p>#23 2-340-578-12 Lifestyle Director <u>Payroll</u> Reimbursement Cassie Passantino – 10/19-11/1</p> <p>Terms: Net 30 Days</p>	<p>\$ 3,000.40</p>
TOTAL	\$ 3,000.40

THANK YOU FOR YOUR BUSINESS!

Dream Finders Reverie at Trailmark
Payroll Reconciliation

11/8/2024 \$3,000.40 October 19 - November 1
-\$6,000.80 Payroll balance due



Reverie at Trailmark Homeowners Association

c/o FS Residential
 1601 SW 80th Terrace
 Plantation, FL 33324

Invoice Number: 1311CCR-4
Date: December 31, 2024

Bill To:
 Six Mile Creek Community Development District
 475 West Town Place, Suite 114
 St. Augustine, FL 32092

#23

	Description	Category	Store/vendor	Amount
	ER-00390 (6130)			
10/24	Break from The Grind (plates, napkins, cups) 2 240 538 472	6130	Publix	\$61.13
	Break from The Grind (coffee and donuts) 472	6130	Dunkin'	\$73.96
	ER-00416 (6130)			
	Wine Down Wednesday (appetizers) 472	6130	Publix	\$149.07
	Wine Down Wednesday (water, wine opener, plates, ice, name tags) 472	6130	Publix	\$71.08
	ER-00410 (6130)			
	Monster Mash Bash (supplies) - 472	6130	Amazon	\$21.08
	Gift cards 472		Amazon	\$90.00
	ER-00435 (6130)			
	Team Trivia 472	6130	Fast Jax Trivia	\$275.00
	Monster Mash Bash (selfie station) 472	6130	Amazon	\$22.35
	Pumpkin Palooza (paint and pumpkins) 472	6130	Amazon	\$119.21
	Monster Mash Bash (large halloween order) - 472	6130	Amazon	\$546.00
	Lifestyle Meet & Greet (food items) 472	6130	Publix	\$209.26
	Pumpkin Palooza (pumpkins) 472	6130	Michaels	\$106.23
	Monster Mash Bash (decorations) 472	6130	Party City	\$10.60
	Monster Mash Bash (halloween decorations) 472	6130	Party City	\$18.64
	Pumpkin Palooza (paper towels/clorox wipes) 472	6130	Publix	\$16.70
	Monster Mash Bash (balloon pump) 472	6130	Amazon	\$15.96
	Monster Mash Bash (Trophies, table cloths, glow party favors) 472	6130	Amazon	\$121.36
	Monster Mash Bash (Balloon Arch) - 472	6130	Amazon	\$14.56
	Monster Mash Bash (tickets, stapler, tape) 472	6130	Staples	\$70.87
	Monster Mash Bash (caldrons/decorations) 472	6130	Party City	\$44.13
	Monster Mash Bash (dessert bar) 472	6130	Publix	\$122.28
	Boo-ZE & Sip (snacks) 472	6130	Publix	\$63.89
	Electronic communication platform 2 240 538 81	6140	Constant Contact	\$24.50
	ER-00471			
11/24	Bingo gift cards 472	6130	Amazon	\$55.00
			Subtotal	\$2,322.86
10/24			10% Credit Card Processing	\$232.29
			Grand Total:	\$2,555.15

Terms: Net 30 Days

THANK YOU FOR YOUR BUSINESS!



Expense Reimbursements

Client: Dream Finders: Reverie TM
Date: 11.14.24
Period: Oct 2024

ER-00390	\$	135.09
ER-00416	\$	220.15
ER-00410	\$	111.08
ER-00435	\$	1,713.15
ER-00452	\$	63.89
ER-00606	\$	24.50
ER-00471	\$	55.00
Total	\$	2,322.86
10% OnPlace Fee	\$	232.29
Total	\$	2,555.15



Expense Report

ER-00390

Total

\$135.09

REVERIE AT TRAILMARK EXP 10.15.24

Submitted By
Samantha Keim
skeim@onplace.life

Report To
Erin Steele
esteele@onplace.life

Submitted On
15 Oct 2024

Report Duration
08 Oct 2024 - 15 Oct 2024

EXPENSE SUMMARY

S.No	Expense Details	Category	Amount (USD)
1.	08 Oct 2024 Merchant : Publix Non Reimbursable Payment Mode : Credit Card Paid Through : Additional Business Expense Card on Business Platinum Customer : Dream Finders LLC [Non-Billable] Project : Reverie at Trailmark Homeowners Association, Inc. Invoice Client : Yes Event Name : Break From The Grind Event Date : 08 Oct 2024 Purchase Summary : Plates, napkins, cups	Event Expenses (6130)	\$61.13

2.

09 Oct 2024

Event Expenses (6130)

\$73.96

Merchant : Dunkin'
Non Reimbursable

Payment Mode : Credit Card

Paid Through : Additional Business Expense Card
on Business Platinum

Customer : Dream Finders LLC [Non-Billable]

Project : Reverie at Trailmark Homeowners
Association, Inc.

Invoice Client : Yes

Event Name : Break From The Grind

Event Date : 08 Oct 2024

Purchase Summary : Coffee and donuts

Submitted By

Approved By

Samantha Keim

Erin Steele

PUBLIX.

Treaty Oaks Marketplace
250 Plaza Blvd
Saint Augustine, FL 32086
Store Manager: Bryan Borstelmann
904-808-9923

PG BLUETILE BEVNP	2.49	T
PG BLUETILE BEVNP	2.49	T
PG BLUETILE BEVNP	2.49	T
VANITY FAIR BEV NK	2.99	T
VANITY FAIR BEV NK	2.99	T
CHINET C/CRSTL PLT	8.79	T
CHINET C/CRSTL PLT	8.79	T
CHINET C/CRSTL PLT	8.79	T
CHINET C/CRSTL 90Z	8.79	T
CHINET C/CRSTL 90Z	8.79	T
Order Total	57.40	
Sales Tax	3.73	
Grand Total	61.13	
Credit	61.13	Payment
Change	0.00	

Receipt ID: 1829 A7P 731 032

PRESTO!

Trace #: 737336

Reference #: 0959062208

Acct #: XXXXXXXXXXXX1102

Purchase American Express

Amount: \$61.13

Auth #: 800411

CREDIT CARD	PURCHASE
A000000025010801	AMERICAN EXPRESS
Entry Method:	Cntctless
Mode:	Issuer

Your cashier was Self-Checkout Lane 1

10/07/2024 16:42 S1829 R173 1032 C0773

Join the Publix family!
Apply today at apply.publix.jobs.
We're an equal opportunity employer.

Publix Super Markets, Inc.



Welcome to Dunkin'
Store #: 364823
975 Florida 16
Saint Augustine, FL 32084
734454 order

CHK 1320
10/8/2024 8:45 AM

Drive Thru

1 50 Munchkins 13.99
1 12 Donuts 13.99
2 Box Hot Orig Cof 45.98
American Express \$73.96
*****1102

Tran Type : Purchase
Entry Mode : INSERTED
Auth Code : 861039
AMERICAN EXPRESS
AID: A000000025010801
No Signature Required
I agree to pay the above total
amount according to the card
issuer
(merchant agreement if credit
voucher)

Subtotal \$73.96
Payment \$73.96
Change Due \$0.00

----- Check Closed -----
10/8/2024 8:48 AM

Donut forget to tell us about
today's visit! Talk to us at
www.DunkinRunsOnYou.com
within 3 days and receive a
FREE CLASSIC DONUT
on your next visit when you
purchase a Medium or Larger Beverage
See restrictions on dunkindonuts.com

Survey Code: 32003-64823-0810-0841

Additional Discounts Will Not Be
Applied to Promotional Offers

Thank You. Come Back Again.
Additional Discounts Will Not Be
Applied to Promotional Offer

Check # 1320
Total Items: 4



Expense Report

ER-00416

Total

\$220.15

10.22.24 REVERIE AT TRAILMARK EXP

Submitted By
Samantha Keim
skeim@onplace.life

Report To
Erin Steele
esteele@onplace.life

Submitted On
22 Oct 2024

Report Duration
16 Oct 2024 - 22 Oct 2024

EXPENSE SUMMARY

S.No	Expense Details	Category	Amount (USD)
1.	16 Oct 2024 Merchant : Publix Non Reimbursable Payment Mode : Credit Card Paid Through : Additional Business Expense Card on Business Platinum Customer : Dream Finders LLC [Non-Billable] Project : Reverie at Trailmark Homeowners Association, Inc. Invoice Client : Yes Event Name : Wine Down Wednesday Event Date : 16 Oct 2024 Purchase Summary : Appetizers	Event Expenses (6130)	\$149.07

2.

17 Oct 2024

Event Expenses (6130)

\$71.08

Merchant : Publix
Non Reimbursable

Payment Mode : Credit Card
Paid Through : Additional Business Expense Card
on Business Platinum

Customer : Dream Finders LLC [Non-Billable]

Project : Reverie at Trailmark Homeowners
Association, Inc.

Invoice Client : Yes

Event Name : Wine Down Wednesday

Event Date : 16 Oct 2024

Purchase Summary : Water, wine opener, plates,
sharpies, ice, name tags

Submitted By

Approved By

Samantha Keim

Erin Steele

Subject: Your Publix Pickup Reminder

Date: Wednesday, October 16, 2024 at 2:30:35 PM Eastern Daylight Time

From: NoReply.Publix@publix.com

To: Samantha Keim



Pickup reminder

Pick up your order today.

Hey Cassie. Your order will be ready for pickup soon.

Order number: 1239-4110

Pickup time

October 16, 2024 at 4:00 PM

Pickup location

Shoppes at Murabella

84 Tuscan Way, St Augustine, FL 32092-1831

✓ **This order has been paid online.**

Your order

Pick up from the Deli



Publix Deli Fresh Fruit Platter, Large

\$39.99

Qty: 1



Boar's Head Prosciutto Skewers, Medium

\$99.98

Qty: 2

Order summary

Subtotal	\$139.97
Tax	\$9.10
Total	\$149.07

Publix

Publix Super Markets | Corporate Office
PO Box 407 | Lakeland, FL 33802-0407

Send mail to the above:
ATTN: Customer Care



This email was sent to skeim@onplace.life. Please do not reply to this email as we are not able to respond to messages at this address.

[Contact us](#)

PUBLIX

Treaty Oaks Marketplace
250 Plaza Blvd
Saint Augustine, FL 32086
Store Manager: Bryan Borstelaann
904-808-9923

PURE LIFE 12P-12OZ	3.89	F
PURE LIFE 12P-12OZ	3.89	F
CHINET C/CRSTL PLT	8.79	I
CHINET C/CRSTL PLT	8.79	I
CHINET C/CRSTL PLT	8.79	I
CHINET C/CRSTL PLT	8.79	I
CORKSCREW	9.19	T
LABELS 1"X3" WHITE	2.29	T
SHARPIE F/P MARKER	2.99	T
PURE LIFE 12P-12OZ	3.89	F
PURE LIFE 12P-12OZ	3.89	F
ICE 7 LB		
1 @ 2 FOR 5.00	2.50	T F
Order Total	67.69	
Sales Tax	3.39	
Grand Total	71.08	
Credit Payment	71.08	
Change	0.00	

Receipt ID: 1829 AGP 760 096

PRESTO!

Trace #: 768916

Reference #: 0728802831

Acct #: XXXXXXXXXXXXX1102

Purchase American Express

Amount: \$71.08

Auth #: 825000

CREDIT CARD

A000000025010801

Entry Method:

Mode:

PURCHASE

AMERICAN EXPRESS

Cntctless

Issuer

Your cashier was Self-Checkout Lane 1

10/16/2024 16:54 S1829 R176 0096 C0776

Join the Publix family!
Apply today at apply.publix.jobs
We're an equal opportunity employer.

Publix Super Markets, Inc.





Expense Report

ER-00410

Total

\$111.08

Reverie at TrailMark 10.22.2024

Submitted By
Cassie Passantino
kpassantino@onplace.life

Report To
Erin Steele
esteele@onplace.life

Submitted On
22 Oct 2024

Report Duration
22 Oct 2024 - 22 Oct 2024

EXPENSE SUMMARY

S.No	Expense Details	Category	Amount (USD)
1.	19 Oct 2024 Merchant : Amazon Non Reimbursable Payment Mode : Credit Card Paid Through : Additional Business Expense Card on Business Platinum Customer : Dream Finders LLC [Non-Billable] Project : Reverie at Trailmark Homeowners Association, Inc. Invoice Client : Yes Event Name : Monster Mash Bash Event Date : 26 Oct 2024 Purchase Summary : Monster Mash Bash Supplies Multiple Transactions	Event Expenses (6130)	\$21.08

2.

20 Oct 2024

Event Expenses (6130)

\$90.00

Merchant : Amazon
Non Reimbursable

Payment Mode : Credit Card
Paid Through : Additional Business Expense Card
on Business Platinum

Customer : Dream Finders LLC [Non-Billable]

Project : Reverie at Trailmark Homeowners
Association, Inc.

Invoice Client : Yes

Event Name : Team Trivia

Event Date : 18 Oct 2024

Purchase Summary : Gift Cards for Team Trivia

Submitted By

Approved By

Cassie Passantino

Erin Steele

Lights Indoor for Home Plant Picture, UL Listed 5.9 FT Plug Cord & Foot Switch

Sold by: SUNVIE (seller profile)

Condition: New

1 of: VOMAOK Halloween Spider Decorations 4ft Light Up Giant Spider(2 Pack) for Indoor Outdoor Halloween Decorations Yard \$27.99

Party House Décor

Sold by: VOMAOK (seller profile)

Condition: New

1 of: Halloween Decorations 3D Changing Face Horror Pictures Moving Portrait Haunted Pictures Gothic Mansion Portraits \$14.99

Tabletop Picture Frame Scary Wall Decoration for Halloween Party House (Chic,6 PCS)

Sold by: Shakeyo (seller profile)

Condition: New

1 of: Black Candlestick Holder Set of 12 for Taper Candles, Decorative Candle Holders Bulk Candle Stick Holders Taper Candle \$38.99

Holders for Table Centerpiece Wedding Dining Party Anniversary Home Decor

Sold by: syleBdz (seller profile)

Condition: New

Shipping Address:

Katharine Passantino
35 RUSTIC MILL DR
SAINT AUGUSTINE, FL 32092-7940
United States

Item(s) Subtotal: \$124.96

Shipping & Handling: \$0.00

Total before tax: \$124.96

Sales Tax: \$8.11

Shipping Speed:

FREE Prime Delivery

Total for This Shipment: \$133.07

Shipped on October 18, 2024

Items Ordered

Price

1 of: Entisn 4 Pack Gold Satin Tablecloth 54 x 54 Inches Table Cloth, Square Silky Tablecloth Smooth Table Cover Decoration for \$19.79
Wedding Party Holiday Dinner

Sold by: Fonbon (seller profile)

Condition: New

1 of: Boao 85 x 197 Inch Halloween Cheesecloth Cheese Cloth Roll for Crafts Large White Cotton Muslin Gauze Fabric for Party \$9.99
Decorations

Sold by: Maitys (seller profile)

Condition: New

Shipping Address:

Katharine Passantino
35 RUSTIC MILL DR
SAINT AUGUSTINE, FL 32092-7940
United States

Item(s) Subtotal: \$29.78

Shipping & Handling: \$0.00

Total before tax: \$29.78

Sales Tax: \$1.94

Shipping Speed:

FREE Prime Delivery

Total for This Shipment: \$31.72

Shipped on October 18, 2024

Items Ordered	Price
<p>1 of: AGPTEK Smoke Machine, Fog Machine with 13 Colorful LED Lights Effect, 500W and 2000CFM Fog with 1 Wired Receiver and 2 Wireless Remote Controls, Perfect for Wedding, Halloween, Party and Stage Effect</p> <p>Sold by: Mambate USA (seller profile)</p> <p>Business Price</p> <p>Condition: New</p>	\$55.89
<p>2 of: Essential Values Fog Machine Liquid - Fluid for Smoke Machine Fog - Long-Lasting Fog Juice - Medium Density Smoke for Water-Based Foggers - For 400-1500 Watt Machines</p> <p>Sold by: Essential Values (seller profile)</p> <p>Condition: New</p>	\$18.99
<p>2 of: Command Medium Utility Hooks, 20 Hooks and 24 Command Strips, Damage Free Hanging Wall Hooks with Adhesive Strips, No Tools Adhesive Hooks for Hanging, Organization and Storage, Holds up to 3 lb</p> <p>Sold by: Amazon (seller profile)</p> <p>Business Price</p> <p>Condition: New</p>	\$16.02
<p>1 of: COCHIE Spooky Black Cat Halloween Table Decorations Indoor, Wooden Black Cats Tiered Tray Decor Set, Wood Black Cat Blocks with Ribbons Party Home Shelf Tabletop Decoration</p> <p>Sold by: COCHIE Direct (seller profile)</p> <p>Condition: New</p>	\$9.74
<p>1 of: suddus Led String Lights, 33FT 100 Led Fairy Lights Plug in, Christmas Lights for Bedroom, Home, Yard, Door, Room, Classroom Decorations Warm White</p> <p>Sold by: suddus (seller profile)</p> <p>Business Price</p> <p>Condition: New</p>	\$13.98

Shipping Address:

Katharine Passantino
 35 RUSTIC MILL DR
 SAINT AUGUSTINE, FL 32092-7940
 United States

Item(s) Subtotal: \$149.63
 Shipping & Handling: \$0.00

 Total before tax: \$149.63
 Sales Tax: \$9.71

Shipping Speed:

FREE Prime Delivery

Total for This Shipment: \$159.34

Shipped on October 18, 2024

Items Ordered	Price
<p>1 of: 5Pack Halloween Decorations Indoor Halloween Decor Black Lace Table Runner Fireplace Mantel Scarf Round Tablecloth Cobweb Lampshade with 32 Pcs 3D Bat Wall Stickers</p> <p>Sold by: Jenfall US (seller profile)</p> <p>Condition: New</p>	\$16.99

Shipping Address:

Katharine Passantino
 35 RUSTIC MILL DR
 SAINT AUGUSTINE, FL 32092-7940
 United States

Item(s) Subtotal: \$16.99
 Shipping & Handling: \$0.00

 Total before tax: \$16.99
 Sales Tax: \$1.10

Shipping Speed:

FREE Prime Delivery

Total for This Shipment: \$18.09

Final Details for Order #112-8252764-2643458

[Print this page for your records.](#)

Order Placed: October 20, 2024
Amazon.com order number: 112-8252764-2643458
Order Total: \$90.00

Gift Cards

Sent	Amount
E-mail gift card to: pgw987@yahoo.com - From: Katharine Passantino - Message: Hope you enjoy this Amazon Gift Card!	\$5.00

Sent	Amount
E-mail gift card to: dee2u_2000@yahoo.com - From: Katharine Passantino - Message: Hope you enjoy this Amazon Gift Card!	\$5.00

Sent	Amount
E-mail gift card to: lydmatt@gmail.com - From: Katharine Passantino - Message: Hope you enjoy this Amazon Gift Card!	\$5.00

Sent	Amount
E-mail gift card to: eagle.em@gmail.com - From: Katharine Passantino - Message: Hope you enjoy this Amazon Gift Card!	\$5.00

Not yet sent	Amount
E-mail gift card to: chuckkersaw@gmail.com - From: Katharine Passantino - Message: Hope you enjoy this Amazon Gift Card!	\$5.00

Received	Amount
E-mail gift card to: maxinebergman1963@yahoo.com - From: Katharine Passantino - Message: Hope you enjoy this Amazon Gift Card!	\$5.00

Received

E-mail gift card to: s.shannon148@comcast.net

- **From:** Katharine Passantino
- **Message:**

Hope you enjoy this Amazon Gift Card!

Amount
\$10.00

Received

E-mail gift card to: scottnamie@gmail.com

- **From:** Katharine Passantino
- **Message:**

Hope you enjoy this Amazon Gift Card!

Amount
\$10.00

Received

E-mail gift card to: scottnamie@gmail.com

- **From:** Katharine Passantino
- **Message:**

Hope you enjoy this Amazon Gift Card!

Amount
\$10.00

Not yet sent

E-mail gift card to: nhail8286@gmail.com

- **From:** Katharine Passantino
- **Message:**

Hope you enjoy this Amazon Gift Card!

Amount
\$10.00

Received

E-mail gift card to: jnicks2712@aol.com

- **From:** Katharine Passantino
- **Message:**

Hope you enjoy this Amazon Gift Card!

Amount
\$10.00

Sent

E-mail gift card to: kpisoborseti@hotmail.com

- **From:** Katharine Passantino
- **Message:**

Hope you enjoy this Amazon Gift Card!

Amount
\$10.00

Payment information

Item(s) Subtotal:	\$90.00

Total before tax:	\$90.00
Estimated tax to be collected:	\$0.00

Grand Total:	\$90.00

Payment Method:

American Express | Last digits: 1284

To view the status of your order, return to Order Summary.

Please note: This is not a VAT invoice.

Conditions of Use | Privacy Notice © 1996-2024, Amazon.com, Inc. or its affiliates

Have an idea to help us improve? Send feedback.

Get to Know Us

- Careers
- Blog
- About Amazon
- Sustainability
- Press Center
- Investor Relations
- Amazon Devices

Let Us Help You

- Customer Service
- Shipping Rates & Policies
- Business FAQ
- Contact Us

Work with Amazon

- Sell on Amazon Business
- Sell on Amazon
- Fulfillment By Amazon
- Advertise on Amazon
- Amazon Global Selling

Business Solutions

- Amazon Business app
- Amazon Business Solutions
- Manage Suppliers
- Purchasing Systems
- Amazon Business Card
- Pay by Invoice
- Purchasing Line
- Amazon Business Blog

Buy For Your Business

- Buy wholesale
- Today's Deals
- Buy Again
- PPE for Work
- Request for quote



Scan the QR code to download the new Amazon Business app



English

United States

Alexa Actionable Analytics for the Web

Sell on Amazon Start a Selling Account

Amazon Marketing Services Self-service Advertising Solutions

Amazon Payments Login and Pay with Amazon

Amazon Web Services Scalable Cloud Computing Services

Mechanical Turk On-demand Scalable Workforce

Buy for Others Kindle eBook Bulk Buying Solution

Conditions of Use | Privacy Notice | Your Ads | Privacy Choices

© 1996-2024, Amazon.com, Inc. or its affiliates



Expense Report

ER-00435

Total

\$1,713.15

Reverie at TrailMark 10.29.2024

Submitted By
Cassie Passantino
kpassantino@onplace.life

Report To
Erin Steele
esteele@onplace.life

Submitted On
29 Oct 2024

Report Duration
22 Oct 2024 - 29 Oct 2024

EXPENSE SUMMARY

S.No	Expense Details	Category	Amount (USD)
1.	19 Oct 2024 Merchant : Fast Jax Trivia Non Reimbursable Payment Mode : Credit Card Paid Through : Additional Business Expense Card on Business Platinum Customer : Dream Finders LLC [Non-Billable] Project : Reverie at Trailmark Homeowners Association, Inc. Invoice Client : Yes Event Name : Team Trivia Event Date : 18 Oct 2024 Purchase Summary : Fast Jax Trivia Team Trivia	Event Expenses (6130)	\$275.00

2.	<p>22 Oct 2024 Merchant : Amazon Non Reimbursable</p> <p>Payment Mode : Credit Card Paid Through : Additional Business Expense Card on Business Platinum Customer : Dream Finders LLC [Non-Billable] Project : Reverie at Trailmark Homeowners Association, Inc. Invoice Client : Yes Event Name : Monster Mash Bash Event Date : 26 Oct 2024 Purchase Summary : Selfie Station Monster Mash Bash</p>	Event Expenses (6130)	\$22.35
3.	<p>22 Oct 2024 Merchant : Amazon Non Reimbursable</p> <p>Payment Mode : Credit Card Paid Through : Additional Business Expense Card on Business Platinum Customer : Dream Finders LLC [Non-Billable] Project : Reverie at Trailmark Homeowners Association, Inc. Invoice Client : Yes Event Name : Pumpkin Palooza Event Date : 23 Oct 2024 Purchase Summary : Pumpkin Palooza Paint and Pumpkins</p>	Event Expenses (6130)	\$119.21
4.	<p>22 Oct 2024 Merchant : Amazon Non Reimbursable</p> <p>Payment Mode : Credit Card Paid Through : Additional Business Expense Card on Business Platinum Customer : Dream Finders LLC [Non-Billable] Project : Reverie at Trailmark Homeowners Association, Inc. Invoice Client : Yes Event Name : Monster Mash Bash Event Date : 26 Oct 2024 Purchase Summary : Large Halloween order Monster Mash Bash</p>	Event Expenses (6130)	\$546.00

5.	<p>22 Oct 2024 Merchant : Publix Non Reimbursable</p> <p>Payment Mode : Credit Card Paid Through : Additional Business Expense Card on Business Platinum Customer : Dream Finders LLC [Non-Billable] Project : Reverie at Trailmark Homeowners Association, Inc. Invoice Client : Yes Event Name : Lifestyle Meet & Greet Event Date : 21 Oct 2024 Purchase Summary : Food items for Lifestyle Meet & Greet</p>	Event Expenses (6130)	\$209.26
6.	<p>23 Oct 2024 Merchant : Michaels Non Reimbursable</p> <p>Payment Mode : Credit Card Paid Through : Additional Business Expense Card on Business Platinum Customer : Dream Finders LLC [Non-Billable] Project : Reverie at Trailmark Homeowners Association, Inc. Invoice Client : Yes Event Name : Pumpkin Palooza Event Date : 23 Oct 2024 Purchase Summary : Pumpkins for Pumpkin Palooza</p>	Event Expenses (6130)	\$106.23
7.	<p>23 Oct 2024 Merchant : Party City Non Reimbursable</p> <p>Payment Mode : Credit Card Paid Through : Additional Business Expense Card on Business Platinum Customer : Dream Finders LLC [Non-Billable] Project : Reverie at Trailmark Homeowners Association, Inc. Invoice Client : Yes Event Name : Monster Mash Bash Event Date : 26 Oct 2024 Purchase Summary : Decorations for Monster Mash Bash</p>	Event Expenses (6130)	\$10.60

8.	<p>23 Oct 2024 Merchant : Party City Non Reimbursable</p> <p>Payment Mode : Credit Card Paid Through : Additional Business Expense Card on Business Platinum Customer : Dream Finders LLC (Non-Billable) Project : Reverie at Trailmark Homeowners Association, Inc. Invoice Client : Yes Event Name : Monster Mash Bash Event Date : 26 Oct 2024 Purchase Summary : Halloween Decorations</p>	Event Expenses (6130)	\$18.64
9.	<p>23 Oct 2024 Merchant : Publix Non Reimbursable</p> <p>Payment Mode : Credit Card Paid Through : Additional Business Expense Card on Business Platinum Customer : Dream Finders LLC (Non-Billable) Project : Reverie at Trailmark Homeowners Association, Inc. Invoice Client : Yes Event Name : Pumpkin Palooza Event Date : 23 Oct 2024 Purchase Summary : Paper towels/ Clorox Wipes</p>	Event Expenses (6130)	\$16.70
10.	<p>24 Oct 2024 Merchant : Amazon Non Reimbursable</p> <p>Payment Mode : Credit Card Paid Through : Additional Business Expense Card on Business Platinum Customer : Dream Finders LLC (Non-Billable) Project : Reverie at Trailmark Homeowners Association, Inc. Invoice Client : Yes Event Name : Monster Mash Bash Event Date : 26 Oct 2024 Purchase Summary : Balloon Pump</p>	Event Expenses (6130)	\$15.96

11.	<p>24 Oct 2024 Merchant : Amazon Non Reimbursable</p> <p>Payment Mode : Credit Card Paid Through : Additional Business Expense Card on Business Platinum Customer : Dream Finders LLC [Non-Billable] Project : Reverie at Trailmark Homeowners Association, Inc. Invoice Client : Yes Event Name : Monster Mash Bash Event Date : 26 Oct 2024 Purchase Summary : Trophies, table cloths, glow party favors</p>	Event Expenses (6130)	\$121.36
12.	<p>26 Oct 2024 Merchant : Amazon Non Reimbursable</p> <p>Payment Mode : Credit Card Paid Through : Additional Business Expense Card on Business Platinum Customer : Dream Finders LLC [Non-Billable] Project : Reverie at Trailmark Homeowners Association, Inc. Invoice Client : Yes Event Name : Monster Mash Bash Event Date : 26 Oct 2024 Purchase Summary : Balloon Arch- Monster Mash Bash</p>	Event Expenses (6130)	\$14.56
13.	<p>26 Oct 2024 Merchant : Staples Non Reimbursable</p> <p>Payment Mode : Credit Card Paid Through : Additional Business Expense Card on Business Platinum Customer : Dream Finders LLC [Non-Billable] Project : Reverie at Trailmark Homeowners Association, Inc. Invoice Client : Yes Event Name : Monster Mash Bash Event Date : 26 Oct 2024 Purchase Summary : Tickets, stapler, and tape for Monster Mash Bash</p>	Event Expenses (6130)	\$70.87

14.	27 Oct 2024 Merchant : Party City Non Reimbursable Payment Mode : Credit Card Paid Through : Additional Business Expense Card on Business Platinum Customer : Dream Finders LLC (Non-Billable) Project : Reverie at Trailmark Homeowners Association, Inc. Invoice Client : Yes Event Name : Monster Mash Bash Event Date : 26 Oct 2024 Purchase Summary : Caldrons/ decorations for Monster Mash Bash	Event Expenses (6130)	\$44.13
-----	--	-----------------------	----------------

15.	27 Oct 2024 Merchant : Publix Non Reimbursable Payment Mode : Credit Card Paid Through : Additional Business Expense Card on Business Platinum Customer : Dream Finders LLC (Non-Billable) Project : Reverie at Trailmark Homeowners Association, Inc. Invoice Client : Yes Event Name : Monster Mash Bash Event Date : 26 Oct 2024 Purchase Summary : Dessert Bar - Monster Mash Bash	Event Expenses (6130)	\$122.28
-----	--	-----------------------	-----------------

Submitted By

Approved By

Cassie Passantino

Erin Steele

← \$275.00 Sale

CARD PAYMENT

10/18/24 9:20 PM

 AmEx 1284 \$275.00

 Receipt #X5HG

 Unknown Name

ITEMS AND SERVICES

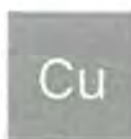
 Custom Amount \$275.00

FEEES ON THIS TRANSACTION

 Keyed (3.5% + 15¢) \$9.78

[Learn more about fees](#)

TOTAL

 Subtotal \$275.00

-  Checkout
-  Transactions
-  Notifications
-  More



Final Details for Order #112-4997686-1523446

Order Placed: October 21, 2024
Amazon.com order number: 112-4997686-1523446
Order Total: \$22.35

Business order information
Client purchasing for: Dream Finders Community purchasing for: Reverie at TrailMark

Shipped on October 22, 2024	
Items Ordered	Price
1 Of: <i>Halloween Backdrop for Photography Halloween Full Moon Night Background 8x6FT Horrible Pumpkin Halloween Theme</i> <i>Baby Shower Birthday Party Decoration Photo Booth Props</i> Sold by: Jinri US Direct (seller profile) Condition: New	\$20.99
Shipping Address: Katharine Passantino 35 RUSTIC MILL DR SAINT AUGUSTINE, FL 32092-7940 United States	Item(s) Subtotal: \$20.99 Shipping & Handling: \$0.00 ----- Total before tax: \$20.99 Sales Tax: \$1.36 -----
Shipping Speed: FREE Prime Delivery	Total for This Shipment: \$22.35 -----

Payment information	
Payment Method: American Express Last digits: 1284	Item(s) Subtotal: \$20.99 Shipping & Handling: \$0.00 -----
Billing address Katharine Passantino 6557 THE MASTERS AVE LAKEWOOD RANCH, FL 34202-2556 United States	Total before tax: \$20.99 Estimated Tax: \$1.36 ----- Grand Total: \$22.35
Credit Card transactions	American Express ending in 1284: October 22, 2024: \$22.35

To view the status of your order, return to [Order Summary](#) .



Final Details for Order #112-0967648-7356259

Order Placed: October 20, 2024
Amazon.com order number: 112-0967648-7356259
Order Total: \$119.21

Business order information
Client purchasing for: Dream Finders Community purchasing for: Reverie at TrailMark

Shipped on October 21, 2024	
Items Ordered	Price
1 of: <i>Vertintong 12 Set Ceramic Pumpkins DIY Painting Kit Fall Theme Ready to Paint Pumpkin Statues Paint Your Own Halloween Pumpkin Figurines Unpainted Crafts with Brush Palette Paint(Pink Color)</i> Sold by: JuuNea (seller profile) Condition: New	\$31.99
Shipping Address: Katharine Passantino 35 RUSTIC MILL DR SAINT AUGUSTINE, FL 32092-7940 United States	Item(s) Subtotal: \$31.99 Shipping & Handling: \$0.00 ----- Total before tax: \$31.99 Sales Tax: \$2.08 -----
Shipping Speed: FREE Prime Delivery	Total for This Shipment: \$34.07 -----

Shipped on October 21, 2024	
Items Ordered	Price
1 of: <i>ROSE KINGDOM Pumpkin Decorating Kit 24Pcs Different Sizes Mini Pumpkins for Decorating Fake Pumpkins Thanksgiving Halloween Fall Home Centerpiece Decor (White)</i> Sold by: Yiwu CityJinbai E-commerce Co., Ltd (seller profile) Condition: New	\$26.99
Shipping Address: Katharine Passantino 35 RUSTIC MILL DR SAINT AUGUSTINE, FL 32092-7940 United States	Item(s) Subtotal: \$26.99 Shipping & Handling: \$0.00 ----- Total before tax: \$26.99 Sales Tax: \$1.75 -----
Shipping Speed: FREE Prime Delivery	Total for This Shipment: \$28.74 -----

Shipped on October 22, 2024	
Items Ordered	Price

<p>3 of: <i>ESRICH Acrylic Paint Brushes Set,8Packs /80 Pcs, Nylon Brush Head, Suitable for Acrylic, Oil, Watercolor,Rock Body Face Nail Art,Perfect Suit of Art Painting, Best Gift for Kids Adult Drawing</i></p> <p>Sold by: ESRICH (seller profile)</p> <p>Condition: New</p>	\$11.99
<p>1 of: <i>Apple Barrel, Vibrant Spectrum Collection Acrylic Craft Paint, PROMOABIII, 2 fl oz each, 16 assorted matte colors, 16 count , Apple Barrel</i></p> <p>Sold by: Amazon (seller profile)</p> <p>Business Price</p> <p>Condition: New</p>	\$16.99

<p>Shipping Address: Katharine Passantino 35 RUSTIC MILL DR SAINT AUGUSTINE, FL 32092-7940 United States</p> <p>Shipping Speed: FREE Prime Delivery</p>	Item(s) Subtotal: \$52.96 Shipping & Handling: \$0.00 ----- Total before tax: \$52.96 Sales Tax: \$3.44 ----- Total for This Shipment: \$56.40 -----
--	--

Payment Information	
<p>Payment Method: American Express Last digits: 1284</p> <p>Billing address Katharine Passantino 6557 THE MASTERS AVE LAKEWOOD RANCH, FL 34202-2556 United States</p>	Item(s) Subtotal: \$111.94 Shipping & Handling: \$0.00 ----- Total before tax: \$111.94 Estimated Tax: \$7.27 ----- Grand Total: \$119.21
<p>Credit Card transactions</p>	<p>American Express ending in 1284: October 22, 2024: \$119.21</p>

To view the status of your order, return to [Order Summary](#) .



Details for Order #112-7574232-4669855

Order Placed: October 18, 2024
Amazon.com order number: 112-7574232-4669855
Order Total: \$581.64

Business order information
Client purchasing for: Dream Finders Community purchasing for: Reverie at TrailMark

Not Yet Shipped				
<table border="0"> <thead> <tr> <th>Items Ordered</th> <th>Price</th> </tr> </thead> <tbody> <tr> <td>1 of: JMEXSUSS Connectable Orange Lights for Halloween, 33ft 100 LED Halloweem String Lights Outdoor with 8 Modes, Plug in Fall Lights Indoor Clear Wire, Halloween Decorations for Party Spooky Decoration Sold by: jmexsuss (seller profile) Condition: New</td> <td>\$13.67</td> </tr> </tbody> </table>	Items Ordered	Price	1 of: JMEXSUSS Connectable Orange Lights for Halloween, 33ft 100 LED Halloweem String Lights Outdoor with 8 Modes, Plug in Fall Lights Indoor Clear Wire, Halloween Decorations for Party Spooky Decoration Sold by: jmexsuss (seller profile) Condition: New	\$13.67
Items Ordered	Price			
1 of: JMEXSUSS Connectable Orange Lights for Halloween, 33ft 100 LED Halloweem String Lights Outdoor with 8 Modes, Plug in Fall Lights Indoor Clear Wire, Halloween Decorations for Party Spooky Decoration Sold by: jmexsuss (seller profile) Condition: New	\$13.67			
Shipping Address: Katharine Passantino 35 RUSTIC MILL DR SAINT AUGUSTINE, FL 32092-7940 United States				
Shipping Speed: FREE Prime Delivery				

Shipped on October 18, 2024																			
<table border="0"> <thead> <tr> <th>Items Ordered</th> <th>Price</th> </tr> </thead> <tbody> <tr> <td>1 of: Halloween Balloons Garland Arch Kit, 126pcs DIY Halloween Party Balloons With Black, Orange, Purple, Fruit Green, Confetti, Balloons, Boo, Spider, Pumpkin Foil Balloons for Halloween Party Decorations Indoor Sold by: SZhaolongfa (seller profile) Condition: New</td> <td>\$14.99</td> </tr> </tbody> </table>	Items Ordered	Price	1 of: Halloween Balloons Garland Arch Kit, 126pcs DIY Halloween Party Balloons With Black, Orange, Purple, Fruit Green, Confetti, Balloons, Boo, Spider, Pumpkin Foil Balloons for Halloween Party Decorations Indoor Sold by: SZhaolongfa (seller profile) Condition: New	\$14.99															
Items Ordered	Price																		
1 of: Halloween Balloons Garland Arch Kit, 126pcs DIY Halloween Party Balloons With Black, Orange, Purple, Fruit Green, Confetti, Balloons, Boo, Spider, Pumpkin Foil Balloons for Halloween Party Decorations Indoor Sold by: SZhaolongfa (seller profile) Condition: New	\$14.99																		
Shipping Address: Katharine Passantino 35 RUSTIC MILL DR SAINT AUGUSTINE, FL 32092-7940 United States	<table border="0"> <tr> <td>Item(s) Subtotal:</td> <td>\$14.99</td> </tr> <tr> <td>Shipping & Handling:</td> <td>\$0.00</td> </tr> <tr> <td>Promotion Applied:</td> <td>-\$1.50</td> </tr> <tr> <td colspan="2">-----</td> </tr> <tr> <td>Total before tax:</td> <td>\$13.49</td> </tr> <tr> <td>Sales Tax:</td> <td>\$0.88</td> </tr> <tr> <td colspan="2">-----</td> </tr> <tr> <td>Total for This Shipment:</td> <td>\$14.37</td> </tr> <tr> <td colspan="2">-----</td> </tr> </table>	Item(s) Subtotal:	\$14.99	Shipping & Handling:	\$0.00	Promotion Applied:	-\$1.50	-----		Total before tax:	\$13.49	Sales Tax:	\$0.88	-----		Total for This Shipment:	\$14.37	-----	
Item(s) Subtotal:	\$14.99																		
Shipping & Handling:	\$0.00																		
Promotion Applied:	-\$1.50																		

Total before tax:	\$13.49																		
Sales Tax:	\$0.88																		

Total for This Shipment:	\$14.37																		

Shipping Speed: FREE Prime Delivery																			

Shipped on October 18, 2024				
<table border="0"> <thead> <tr> <th>Items Ordered</th> <th>Price</th> </tr> </thead> <tbody> <tr> <td>1 of: SUNVIE 2 Pack Up Lights Indoor Floor Can Light Uplighting Indoor Spotlight with 2700K GU10 Bulb Accent Lighting Spot</td> <td>\$42.99</td> </tr> </tbody> </table>	Items Ordered	Price	1 of: SUNVIE 2 Pack Up Lights Indoor Floor Can Light Uplighting Indoor Spotlight with 2700K GU10 Bulb Accent Lighting Spot	\$42.99
Items Ordered	Price			
1 of: SUNVIE 2 Pack Up Lights Indoor Floor Can Light Uplighting Indoor Spotlight with 2700K GU10 Bulb Accent Lighting Spot	\$42.99			

Lights Indoor for Home Plant Picture, UL Listed 5.9 FT Plug Cord & Foot Switch

Sold by: SUNVIE ([seller profile](#))

Condition: New

1 of: VOMAOK Halloween Spider Decorations 4ft Light Up Giant Spider(2 Pack) for Indoor Outdoor Halloween Decorations Yard Party House Décor \$27.99

Sold by: VOMAOK ([seller profile](#))

Condition: New

1 of: Halloween Decorations 3D Changing Face Horror Pictures Moving Portrait Haunted Pictures Gothic Mansion Portraits Tabletop Picture Frame Scary Wall Decoration for Halloween Party House (Chic, 6 PCS) \$14.99

Sold by: Shakeyo ([seller profile](#))

Condition: New

1 of: Black Candlestick Holder Set of 12 for Taper Candles, Decorative Candle Holders Bulk Candle Stick Holders Taper Candle Holders for Table Centerpiece Wedding Dining Party Anniversary Home Decor \$38.99

Sold by: syleBdz ([seller profile](#))

Condition: New

Shipping Address:

Katharine Passantino
35 RUSTIC MILL DR
SAINT AUGUSTINE, FL 32092-7940
United States

Item(s) Subtotal: \$124.96
Shipping & Handling: \$0.00

Total before tax: \$124.96
Sales Tax: \$8.11

Shipping Speed:

FREE Prime Delivery

Total for This Shipment: \$133.07

Shipped on October 18, 2024

Items Ordered

Price

1 of: Entisn 4 Pack Gold Satin Tablecloth 54 x 54 Inches Table Cloth, Square Silky Tablecloth Smooth Table Cover Decoration for Wedding Party Holiday Dinner \$19.79

Sold by: Fonbon ([seller profile](#))

Condition: New

1 of: Boao 85 x 197 Inch Halloween Cheesecloth Cheese Cloth Roll for Crafts Large White Cotton Muslin Gauze Fabric for Party Decorations \$9.99

Sold by: Maitys ([seller profile](#))

Condition: New

Shipping Address:

Katharine Passantino
35 RUSTIC MILL DR
SAINT AUGUSTINE, FL 32092-7940
United States

Item(s) Subtotal: \$29.78
Shipping & Handling: \$0.00

Total before tax: \$29.78
Sales Tax: \$1.94

Shipping Speed:

FREE Prime Delivery

Total for This Shipment: \$31.72

Shipped on October 18, 2024

Items Ordered	Price
<p>1 of: AGPTEK Smoke Machine, Fog Machine with 13 Colorful LED Lights Effect, 500W and 2000CFM Fog with 1 Wired Receiver and 2 Wireless Remote Controls, Perfect for Wedding, Halloween, Party and Stage Effect</p> <p>Sold by: Mambate USA (seller profile)</p> <p>Business Price</p> <p>Condition: New</p>	\$55.89
<p>2 of: Essential Values Fog Machine Liquid - Fluid for Smoke Machine Fog - Long-Lasting Fog Juice - Medium Density Smoke for Water-Based Foggers - For 400-1500 Watt Machines</p> <p>Sold by: Essential Values (seller profile)</p> <p>Condition: New</p>	\$18.99
<p>2 of: Command Medium Utility Hooks, 20 Hooks and 24 Command Strips, Damage Free Hanging Wall Hooks with Adhesive Strips, No Tools Adhesive Hooks for Hanging, Organization and Storage, Holds up to 3 lb</p> <p>Sold by: Amazon (seller profile)</p> <p>Business Price</p> <p>Condition: New</p>	\$16.02
<p>1 of: COCHIE Spooky Black Cat Halloween Table Decorations Indoor, Wooden Black Cats Tiered Tray Decor Set, Wood Black Cat Blocks with Ribbons Party Home Shelf Tabletop Decoration</p> <p>Sold by: COCHIE Direct (seller profile)</p> <p>Condition: New</p>	\$9.74
<p>1 of: suddus Led String Lights, 33FT 100 Led Fairy Lights Plug in, Christmas Lights for Bedroom, Home, Yard, Door, Room, Classroom Decorations Warm White</p> <p>Sold by: suddus (seller profile)</p> <p>Business Price</p> <p>Condition: New</p>	\$13.98

<p>Shipping Address: Katharine Passantino 35 RUSTIC MILL DR SAINT AUGUSTINE, FL 32092-7940 United States</p> <p>Shipping Speed: FREE Prime Delivery</p>	Item(s) Subtotal: \$149.63
	Shipping & Handling: \$0.00

	Total before tax: \$149.63
	Sales Tax: \$9.71
	Total for This Shipment: \$159.34

Shipped on October 18, 2024

Items Ordered	Price
<p>1 of: 5Pack Halloween Decorations Indoor Halloween Decor Black Lace Table Runner Fireplace Mantel Scarf Round Tablecloth Cobweb Lampshade with 32 Pcs 3D Bat Wall Stickers</p> <p>Sold by: Jenfall US (seller profile)</p> <p>Condition: New</p>	\$16.99

<p>Shipping Address: Katharine Passantino 35 RUSTIC MILL DR SAINT AUGUSTINE, FL 32092-7940 United States</p> <p>Shipping Speed: FREE Prime Delivery</p>	Item(s) Subtotal: \$16.99
	Shipping & Handling: \$0.00

	Total before tax: \$16.99
	Sales Tax: \$1.10
	Total for This Shipment: \$18.09

Shipped on October 18, 2024

Items Ordered

Price

1 Of: <i>Gaffer Power Proudly Made in The USA, Real Professional Grade Gaffer Tape, Heavy Duty Gaffers Tape, Non-Reflective, Multipurpose. 2 Inches x 30 Yards, Black</i> Sold by: Gaffer Power (seller profile) Business Price Condition: New	\$19.49
1 Of: <i>Homemory 24-Pack Melting Black Candles Battery Operated Tea Lights, Halloween Flameless Flickering Candles, Ideal for Holiday Decor, Theme Party, Dia 1-2/5" x H 1-1/4"</i> Sold by: AMAGIC-US (seller profile) Condition: New	\$12.99

Shipping Address:

Katharine Passantino
35 RUSTIC MILL DR
SAINT AUGUSTINE, FL 32092-7940
United States

Item(s) Subtotal:	\$32.48
Shipping & Handling:	\$0.00

Total before tax:	\$32.48
Sales Tax:	\$2.11

Shipping Speed:

FREE Prime Delivery

Total for This Shipment: \$34.59

Shipped on October 19, 2024

Items Ordered

Price

1 Of: <i>Mega-L Halloween Tinsel Garland Decorations, 26.25Ft Orange Purple and Black Color Bat Chunky Glittery Holiday Hanging Tinsel Decorations for Halloween Theme Birthday Party Supplies Home Decor</i> Sold by: Cherrystar Mall (seller profile) Business Price Condition: New	\$15.99
1 Of: <i>Enjoyedled DJ Disco Stage Party Lights - Northern Laser Light Effect RGB Led Sound Activated Strobe Lighting with Remote Control for Indoor Birthday Halloween Karaoke Club KTV</i> Sold by: Enjoyedled (seller profile) Condition: New	\$29.59
1 Of: <i>Winlyn 12 Pcs Assorted Artificial Black Pumpkins Small Fall Halloween Decorative Pumpkins Faux Foam Pumpkins for Autumn Home Thanksgiving Halloween Party Table Centerpiece Mantel Shelf Decorations</i> Sold by: Winlyn (seller profile) Condition: New	\$9.99

Shipping Address:

Katharine Passantino
35 RUSTIC MILL DR
SAINT AUGUSTINE, FL 32092-7940
United States

Item(s) Subtotal:	\$55.57
Shipping & Handling:	\$0.00

Total before tax:	\$55.57
Sales Tax:	\$3.61

Shipping Speed:

FREE Prime Delivery

Total for This Shipment: \$59.18

Shipped on October 19, 2024

Items Ordered

Price

1 of: *Runleo Halloween Pumpkin String Lights, 30 LED 16.4 FT 8 Modes Timer 3D Waterproof Orange Jack-O-Lantern Battery Operated Decorative Twinkle Lights for Indoor Bedroom Camper Decor Party Decorations*
Sold by: LINDALIN-US ([seller profile](#))
Condition: New

\$12.99

Shipping Address:

Katharine Passantino
35 RUSTIC MILL DR
SAINT AUGUSTINE, FL 32092-7940
United States

Item(s) Subtotal: \$12.99

Shipping & Handling: \$0.00

Total before tax: \$12.99

Sales Tax: \$0.84

Shipping Speed:

FREE Prime Delivery

Total for This Shipment: \$13.83

Shipped on October 19, 2024

Items Ordered

Price

1 of: *AnyDesign 80 Pack Halloween Pumpkin Paper Napkins Disposable Gold Orange Pumpkin Napkins Halloween Boo Decorative Dessert Dinner Hand Napkin for Halloween Party Supplies, 6.5 x 6.5 Inch*
Sold by: AnyDesign US ([seller profile](#))
Business Price
Condition: New

\$14.98

Shipping Address:

Katharine Passantino
35 RUSTIC MILL DR
SAINT AUGUSTINE, FL 32092-7940
United States

Item(s) Subtotal: \$14.98

Shipping & Handling: \$0.00

Total before tax: \$14.98

Sales Tax: \$0.97

Shipping Speed:

FREE Prime Delivery

Total for This Shipment: \$15.95

Shipped on October 19, 2024

Items Ordered

Price

1 of: *YNYLCHMX 18" Halloween Wreath for Front Door, Halloween Door Wreaths, Fall Autumn Farmhouse Wreath with Golden and Black Maple Leaves for Home Winsow Decorations Indoor Outdoor Party Decor*
Sold by: YNYLCHMX ([seller profile](#))
Business Price
Condition: New

\$11.99

Shipping Address:

Katharine Passantino
35 RUSTIC MILL DR
SAINT AUGUSTINE, FL 32092-7940
United States

Item(s) Subtotal: \$11.99

Shipping & Handling: \$0.00

Total before tax: \$11.99

Sales Tax: \$0.78

Shipping Speed:
FREE Prime Delivery

Total for This Shipment: \$12.77

Shipped on October 19, 2024

Items Ordered

Price

1 Of: *Balloon Arch Decorating Kit - 2 Rolls Tape Strips and Glue Dots for Garlands, Party and Wedding Decorations*
Sold by: SmellS ([seller profile](#))
Condition: New

\$3.89

Shipping Address:
Katharine Passantino
35 RUSTIC MILL DR
SAINT AUGUSTINE, FL 32092-7940
United States

Item(s) Subtotal: \$3.89
Shipping & Handling: \$0.00

Total before tax: \$3.89
Sales Tax: \$0.25

Shipping Speed:
FREE Prime Delivery

Total for This Shipment: \$4.14

Shipped on October 19, 2024

Items Ordered

Price

1 Of: *Entisn 4 Pack Gold Satin Tablecloth 54 x 54 Inches Table Cloth, Square Silky Tablecloth Smooth Table Cover Decoration for Wedding Party Holiday Dinner*
Sold by: Fonbon ([seller profile](#))
Condition: New

\$19.79

1 Of: *CANDWAX 10 Inch Taper Candles Set of 12 - Tall Candles Unscented - Orange Tapered Candle Sticks Perfect as Halloween Taper Candles - Orange Candles*
Sold by: Malanka Store ([seller profile](#))
Business Price
Condition: New

\$16.00

Shipping Address:
Katharine Passantino
35 RUSTIC MILL DR
SAINT AUGUSTINE, FL 32092-7940
United States

Item(s) Subtotal: \$35.79
Shipping & Handling: \$0.00

Total before tax: \$35.79
Sales Tax: \$2.33

Shipping Speed:
FREE Prime Delivery

Total for This Shipment: \$38.12

Shipped on October 19, 2024

Items Ordered

Price

1 Of: *SHYMERY Mini Lantern with Flickering LED Candles, Vintage Black Decorative Hanging Candle Lanterns for Halloween, Wedding Decorations, Christmas, Table Centerpiece, Battery Included Set of 6*
Sold by: ShymeryDirect ([seller profile](#))
Condition: New

\$16.98

Shipping Address: Katharine Passantino 35 RUSTIC MILL DR SAINT AUGUSTINE, FL 32092-7940 United States	Item(s) Subtotal: \$16.98 Shipping & Handling: \$0.00 ----- Total before tax: \$16.98 Sales Tax: \$1.10 -----
Shipping Speed: FREE Prime Delivery	Total for This Shipment: \$18.08 -----

Shipped on October 21, 2024

Items Ordered	Price
1 of: <i>Halatool 8 Pack Halloween Creepy Cloth - 30 x 75 Inch Creepy and Spooky Halloween Decorations for Halloween Party</i> <i>Supplies Outdoor Yard Home Wall Decor 2 Black, 2 White, 2 Purple, 2 Orange</i> Sold by: Halatool (seller profile) Condition: New	\$12.99

Shipping Address: Katharine Passantino 35 RUSTIC MILL DR SAINT AUGUSTINE, FL 32092-7940 United States	Item(s) Subtotal: \$12.99 Shipping & Handling: \$0.00 ----- Total before tax: \$12.99 Sales Tax: \$0.84 -----
Shipping Speed: FREE Prime Delivery	Total for This Shipment: \$13.83 -----

Payment Information

Payment Method: American Express I Last digits: 1284	Item(s) Subtotal: \$547.68 Shipping & Handling: \$0.00 Promotion applied: -\$1.50 -----
Billing address Katharine Passantino 6557 THE MASTERS AVE LAKEWOOD RANCH, FL 34202-2556 United States	Total before tax: \$546.18 Estimated Tax: \$35.46 -----
	Grand Total: \$581.64
Credit Card transactions	American Express ending in 1284: October 19, 2024: \$21.08

To view the status of your order, return to [Order Summary](#).

Publix

Cobblestone Plaza
125 Jenkins St.
St Augustine, FL 32086
Store Manager: Meredith Pearson
904-808-9929



0099 ALP 043 872

DUKES MAYO REAL SQ	5.69	F
DUKES MAYO REAL SQ	5.69	F
Promotion	-5.69	F
FRENCHS SQ MUSTARD	2.49	F
PBX SUB SELECT S	28.99	T F
PBX SUB SELECT L	69.99	T F
PUBLIX SPG 24-8OZ	4.19	F
PUBLIX SPG 24-8OZ	4.19	F
PBX WRAP VARIETY L	69.99	T F
DELI LEMONADE GAL	3.99	T F
DELI LEMONADE GAL	3.99	T F
PBX DELI TEA SWT G	3.99	T F

Order Total	197.50	
Sales Tax	11.76	
Grand Total	209.26	
Credit	Payment	209.26
Change	0.00	

Savings Summary

Special Price Savings 5.69

* Your Savings at Publix *

* 5.69 *

* IN THE MARKET *

* FOR \$1,000 IN GROCERIES? *

* *

* Use this receipt to complete a *

* survey at PublixSurvey.com for *

* a chance to win \$1000 in *

* Publix gift cards. *

* *

* NO PURCH NEC. You must be legal *

* age+. Other eligibility *

Michael's

Everything to create anything™

MICHAELS STORE #3717 (904)829-9664

310 CBL DR.

ST. AUGUSTINE, FL 32086

Rewards Number: LMR90724101168

8-9645-5955-0299-8240-5628-1183-1543-2843



4161396 SALE 7436 3717 040 10/22/24 12.11
ASH CRAFT PUMPKIN 195158171624 9.99
25 @ 3.99 99.75 P

YOU SAVED \$ 150.00

SUBTOTAL 99.75
Sales Tax 6.5% 6.48
TOTAL 106.23

ACCOUNT NUMBER *****1284

AMEX 106.23

APPROVAL: 826720 Contactless ONLINE

Application Label: AMERICAN EXPRESS

AID: A000000025010801

TVR: 0000008000

TSI: E800

This receipt expires at 60 days on 12/19/24

Previous Michaels Rewards Balance: \$0.00

Click Buy. Create. Shop michaels.com today!

Get Savings & Inspiration! Text* SIGNUP to 273283

To Sign Up for Email & Text Messages.

*Msg & Data Rates May Apply

You will receive 1 autodialed message
with a link to join Michaels alerts.

Now Hiring! Apply at michaels.com/jobs

THANK YOU FOR SHOPPING AT MICHAELS

Effective 11/27/2022 Clearance sales are considered
final, sold AS IS and are not
returnable for a refund or exchange.

Dear Valued Customer:

Michaels return and coupon policies are available
at michaels.com and in store at registers.

10/22/24 12:11

Party City®

NOBODY HAS MORE PARTY FOR LESS

440 CBL DRIVE, SUITE 101
SAINT AUGUSTINE, FL 32086
904-640-8151

192937347966 WNDW SILHOU	\$6.99	T
WNDW SILHOUETTE SELFIE SKELETN		
ORIG PRICE (\$6.99 ea)		
PROMO DISCOUN	\$4.54	-
192937337967 DOOR CURTAIN	\$9.99	T
DOOR CURTAIN VINTAGE HLLWN		
ORIG PRICE (\$9.99 ea)		
PROMO DISCOUN	\$4.99	-
192937347898 STAND SGN VN	\$10.00	T
SIAND SGN VNTG HLWN WHEEL/FATE		
ORIG PRICE (\$10.00 ea)		
PROMO DISCOUN	\$7.50	-

SUBTOTAL	\$9.95	
GEN MERCH TAX @ 6.500%	\$0.65	
TOTAL	\$10.60	
CR AMEX	\$10.60	
ITEMS = 3	YOU SAVED \$17.03	

XXXXXXXXXXXX1284 PROXIMITY
APPR: 838163
Application Label: AMERICAN EXPRESS
AC: A803A718F8FFF841
TVR: 0000008000
AID: A000000025010801
TS1: A800
ARC: 00

STORE 914 TRN 53 REG 4
10-22-2024 11:36:17 AM

1E2 1148 004 0251



1E211480040251

We will happily accept returns.

Party City®

NOBODY HAS MORE PARTY FOR LESS

440 CBL DRIVE, SUITE 101
SAINT AUGUSTINE, FL 32086
904-640-8151

048419948223 54X108IN WHI	\$11.92	T
54X108IN WHI TC PLSTC		
8 @ \$1.49		
4 FOR \$5 TC C	\$1.92	-
048419948193 54X108IN DRN	\$8.94	T
54X108IN DRNG TC PLSTC		
6 @ \$1.49		
4 FOR \$5 TC C	\$1.44	-

SUBTOTAL	\$17.50	
GEN MERCH TAX @ 6.500%	\$1.14	
TOTAL	\$18.64	
CR AMEX	\$18.64	
ITEMS = 14	YOU SAVED \$3.36	

XXXXXXXXXXXX1284 PROXIMITY
APPR: 864294
Application Label: AMERICAN EXPRESS
AC: D56226A75010AEOC
TVR: 0000008000
AID: A000000025010801
TS1: A800
ARC: 00

STORE 914 TRN 54 REG 4
10-22-2024 11:41:38 AM

1E2 1148 004 0262



1E211480040262

We will happily accept returns
and exchanges within 30 days
of purchase with original
receipt. All we ask is the
items are in new condition with
original packaging. All

Publix

Cobblestone Plaza
125 Jenkins St.
St. Augustine, FL 32086
Store Manager: Meredith Pearson
904-808-9929



0099 AMP 044 104

SPARKLE 2=4 WH TAS	3.49 T	
You Saved	0.50	
CLOROX DIS/WIPES	12.19 T	
Order Total	15.68	
Sales Tax	1.02	
Grand Total	16.70	
Credit	Payment	16.70
Change	0.00	

Savings Summary

Special Price Savings 0.50

* Your Savings at Publix *
* 0.50 *

* * * * *

* IN THE MARKET * * * * *

* FOR \$1,000 IN GROCERIES? * * * * *

* * * * *

* Use this receipt to complete a * * * * *

* survey at PublixSurvey.com for * * * * *

* a chance to win \$1000 in * * * * *

* Publix gift cards. * * * * *

* * * * *

* NO PURCH NEC. You must be legal * * * * *

* age+. Other eligibility * * * * *

* restrictions apply. See Official * * * * *

* Rules (publixsurvey.com) for * * * * *

* eligibility & prize info, odds, * * * * *

* free entry method & * * * * *

* other details. * * * * *

* * * * *

* ¿LE GUSTARÍAN \$1000 PARA SU * * * * *

* COMPRA DE SUPERMERCADO? * * * * *

* Use este comprobante y visite * * * * *

* publixsurvey.com * * * * *



Final Details for Order #112-3573626-1315416

Order Placed: October 22, 2024
Amazon.com order number: 112-3573626-1315416
Order Total: \$15.96

Business order information
Client purchasing for: Dream Finders Community purchasing for: Reverie at TrailMark

Shipped on October 23, 2024	
Items Ordered	Price
1 of: IDAODAN Electric Balloon Pump, Portable Electric Balloon Blower Machine Balloon Air Pump Dual Nozzle Rose Red 110V 600W Balloon Inflator for Party Decorations Sold by: ChanBasics (seller profile) Business Price Condition: New	\$14.99
Shipping Address: Katharine Passantino 35 RUSTIC MILL DR SAINT AUGUSTINE, FL 32092-7940 United States	Item(s) Subtotal: \$14.99 Shipping & Handling: \$0.00 ----- Total before tax: \$14.99 Sales Tax: \$0.97 -----
Shipping Speed: FREE Prime Delivery	Total for This Shipment: \$15.96 -----

Payment information	
Payment Method: American Express Last digits: 1284	Item(s) Subtotal: \$14.99 Shipping & Handling: \$0.00 -----
Billing address Katharine Passantino 6557 THE MASTERS AVE LAKEWOOD RANCH, FL 34202-2556 United States	Total before tax: \$14.99 Estimated Tax: \$0.97 ----- Grand Total: \$15.96
Credit Card transactions	American Express ending in 1284: October 23, 2024: \$15.96

To view the status of your order, return to [Order Summary](#).



Final Details for Order #112-8199740-8257867

Order Placed: October 21, 2024
Amazon.com order number: 112-8199740-8257867
Order Total: \$121.36

Business order information
Client purchasing for: Dream Finders Community purchasing for: Reverie at TrailMark

Shipped on October 22, 2024	
Items Ordered	Price
1 Of: 6 Pack Halloween Trophies Best Costume Skeleton Trophies for Halloween Party, Skeleton Costume Contest Awards, Plastic Gold Awards Prizes Trophies for kids adults Favor Party, Game Prizes Sold by: Tiny Whale Design (seller profile) Condition: New	\$21.99
Shipping Address: Katharine Passantino 35 RUSTIC MILL DR SAINT AUGUSTINE, FL 32092-7940 United States	Item(s) Subtotal: \$21.99 Shipping & Handling: \$0.00 ----- Total before tax: \$21.99 Sales Tax: \$1.43 -----
Shipping Speed: Delivery in fewer trips to your address	Total for This Shipment: \$23.42 -----

Shipped on October 23, 2024	
Items Ordered	Price
2 Of: Smiry 2 Pack Spandex Table Cloth 6FT, Elastic Fitted Stretch Tablecloths for Rectangle Tables, Washable Table Cover for Outdoor, Wedding, Banquet & Parties (Black, 72Lx30Wx30H Inch) Sold by: Smiry (seller profile) Business Price Condition: New	\$18.98
1 Of: Command 20 lb XL Heavyweight Picture Hanging Strips 16 Pairs (32 Command Strips), Damage Free Hanging Picture Hangers, Heavy Duty Wall Hanging Strips for Christmas Decorations Sold by: Amazon (seller profile) Business Price Condition: New	\$15.02
1 Of: OLUPP 325PCS Glow in the Dark Party Supplies, Glow Sticks Glasses Favors, 300 PCS Glow Sticks and 25 PCS LED Glasses, Neon Party Favors for Glow Party, Wedding, Concert, Raves, Birthday, New Year Sold by: OLUPP (seller profile) Condition: New	\$38.99
Shipping Address: Katharine Passantino 35 RUSTIC MILL DR	Item(s) Subtotal: \$91.97 Shipping & Handling: \$0.00

SAINT AUGUSTINE, FL 32092-7940
United States

Total before tax: \$91.97
Sales Tax: \$5.97

Shipping Speed:
Delivery in fewer trips to your address

Total for This Shipment: \$97.94

Payment information

Payment Method:
American Express | Last digits: 1284

Item(s) Subtotal: \$113.96
Shipping & Handling: \$0.00

Billing address
Katharine Passantino
6557 THE MASTERS AVE
LAKEWOOD RANCH, FL 34202-2556
United States

Total before tax: \$113.96
Estimated Tax: \$7.40

Grand Total: \$121.36

Credit Card transactions

American Express ending in 1284: October 24, 2024: \$121.36

To view the status of your order, return to [Order Summary](#).

[Conditions of Use](#) | [Privacy Notice](#) © 1996-2020, Amazon.com, Inc.

Shipping Address:
Katharine Passantino
35 RUSTIC MILL DR
SAINT AUGUSTINE, FL 32092-7940
United States

Item(s) Subtotal: \$12.99
Shipping & Handling: \$0.00

Total before tax: \$12.99
Sales Tax: \$0.84

Shipping Speed:
FREE Prime Delivery

Total for This Shipment: \$13.83

Shipped on October 26, 2024

Items Ordered

Price

1 of: *JMEXSUSS Connectable Orange Lights for Halloween, 33ft 100 LED Halloweem String Lights Outdoor with 8 Modes, Plug in Fall Lights Indoor Clear Wire, Halloween Decorations for Party Spooky Decoration*
Sold by: jmexsuss ([seller profile](#))
Condition: New

\$13.67

Shipping Address:
Katharine Passantino
35 RUSTIC MILL DR
SAINT AUGUSTINE, FL 32092-7940
United States

Item(s) Subtotal: \$13.67
Shipping & Handling: \$0.00

Total before tax: \$13.67
Sales Tax: \$0.89

Shipping Speed:
FREE Prime Delivery

Total for This Shipment: \$14.56

Payment information

Payment Method:
American Express | Last digits: 1284

Item(s) Subtotal: \$547.68
Shipping & Handling: \$0.00
Promotion applied: -\$1.50

Billing address
Katharine Passantino
6557 THE MASTERS AVE
LAKEWOOD RANCH, FL 34202-2556
United States

Total before tax: \$546.18
Estimated Tax: \$35.46

Grand Total: \$581.64

Credit Card transactions

American Express ending in 1284: October 26, 2024: \$14.56
American Express ending in 1284: October 19, 2024: \$21.08
American Express ending in 1284: October 21, 2024: \$546.00

To view the status of your order, return to [Order Summary](#).



1775 US Highway 1 South Suite 1781
St. Augustine, FL 32084
904-819-1256

Sale

Store: 1071 Register: 2
Date: 10/25/24 Time: 11:31 AM
Transaction: 78567 Cashier: 2051598

Qty	Item	Price	Amount
1	STPLS RCYCL 2 TIX 718103130172	29.99	29.99
1	SMGLN 545 FULLSIRI 074711545679	14.99	14.99
1	SCOTCH MGC TAPE 2P 021200523588	4.99	4.99
1	SCOTCH WALLSAFE TA 076308875534	6.79	6.79
1	SCOTCH DBLSIDED TA 021200523595	5.99	5.99
1	TR STANDARD STAPLE 718103424684	3.79	3.79

Subtotal 66.54
FLORIDA 6.5% 4.33

Total 70.87

AMERICAN EXPRESS USD\$70.87

Card No. : XXXXXXXXXXXX1284 [T]

Contactless

Auth No. : 893877

Mode.: Issuer

AID.: A000000025010801

TVR.: 0000008000

IAD.: 06650103A03002

TSI.: E800

ARC.: 3030

Party City®

NOBODY HAS MORE PARTY FOR LESS

440 CBL DRIVE, SUITE 101
SAINT AUGUSTINE, FL 32086
904-640-8151

831687046995 PNK PMPKN BC \$1.99 T
PNK PMPKN BCKT

FREE TRT BUCK \$1.99 -

078304550804 BLK CAULDRON \$29.94 T

BLK CAULDRON 8IN

6 @ \$4.99

192937245132 ORNG/BLK DEC \$15.00 T

ORNG/BLK DECO KIT HLLWN FAN

ORIG PRICE (\$15.00 ea)

PROMO DISCOUN \$7.50 -

192937402184 2CT DBL BNR \$10.00 T

2CT DBL BNR HPY HLLWN

ORIG PRICE (\$10.00 ea)

PROMO DISCOUN \$6.00 -

SUBTOTAL \$41.44

GEN MERCH TAX @ 6.500% \$2.69

TOTAL \$44.13

CR AMEX \$44.13

ITEMS = 9 YOU SAVED \$15.49

XXXXXXXXXXXX1284 PROXIMITY

APPR: 882841

Application Label: AMERICAN EXPRESS

AC: 3D8E7E7AB4FFC20F

TVR: 0000008000

AID: A000000025010801

TSI: A800

ARC: 00

Publix

Cobblestone Plaza
125 Jenkins St.
St. Augustine, FL 32086
Store Manager: Meredith Pearson
904-808-9929



0099 ARP 057 264

ICE 7 LB		
1 @ 2 FOR	5.00	2.50 T F
ICE 7 LB		
1 @ 2 FOR	5.00	2.50 T F
24CT ASSORTED CKIE		3.99 F
You Saved	1.00	
24CT CHOC CHIP CKI		3.99 F
You Saved	1.00	
24CT SUGAR COOKIES		3.99 F
You Saved	1.00	
BROWNIE ROUNDS		3.99 F
You Saved	0.60	
BROWNIE ROUNDS		3.99 F
You Saved	0.60	
CPCKE MINI 12CT VA		5.29 F
CPCKE 6CT BC ASST		4.99 F
You Saved	1.00	
CPCKE 6CT BC ASST		4.99 F
You Saved	1.00	
CPCKE 6CT BC ASST		4.99 F
You Saved	1.00	
MARS MIXED PARTY M		8.99 T F
You Saved	3.00	
HSY ASSTD HAL 65PC		19.99 T F
HSY ASSRTED MINIS		17.79 T F
CHINET C/CRSTL PLT		8.79 T
SPARKLE 6-12 PAS		8.63 T
PUBLIX SPG 24-80Z		
2 @ 4.19		8.38 F

Order Total	117.78	
Sales Tax	4.50	
Grand Total	122.28	
Credit	Payment	122.28
Change	0.00	

Savings Summary

Special Price Savings	10.20

* Your Savings at Publix *	
* 10.20 *	

Receipt ID: 0099 ARP 057 264

PRESTO!

Trace #: 058076

Reference #: 0977599593

Acct #: XXXXXXXXXXX1284

Purchase American Express

Amount: \$122.28

Auth #: 823640



Expense Report

ER-00452

Total

\$63.89

Reverie at TrailMark 11.05.2024

Submitted By
Cassie Passantino
kpassantino@onplace.life

Report To
Erin Steele
esteele@onplace.life

Submitted On
05 Nov 2024
Report Duration
05 Nov 2024 - 05 Nov 2024

EXPENSE SUMMARY

S.No	Expense Details	Category	Amount (USD)
1.	30 Oct 2024 Merchant : Publix Non Reimbursable Payment Mode : Credit Card Paid Through : Additional Business Expense Card on Business Platinum Customer : Dream Finders LLC (Non-Billable) Project : Reverie at Trailmark Homeowners Association, Inc. Invoice Client : Yes Event Name : BOO-ZE & Sip Event Date : 29 Oct 2024 Purchase Summary : Snacks for BOO-ZE & Sip	Event Expenses (6130)	\$63.89

Submitted By

Approved By

Cassle Passantino

Erin Steele

publix

Shoppes at Mirabella
84 Tuscan Way
Saint Augustine, FL 32092
Store Manager: Kevin Carine
904-940-2889



1239 AUP 076 312

LARGE VEG. PLATTER	15.99	F
FRUIT SALAD LARGE	19.01	F
13CT LMN MEYER CKI	5.99	F
24CT CHOC CHIP CKI	3.99	F
You Saved	1.00	
PR STY TRAY	2.99	T
PR STY TRAY	2.99	T
VANITY FAIR BEV NK	2.99	T
CHINET C/CRSTL PLT	8.79	T

Order Total	67.74	
Sales Tax	1.15	
Grand Total	63.89	
Credit	Payment	63.89
Change	0.00	

Savings Summary

Special Price Savings	1.00

* Your Savings at Publix *	
* 1.00 *	

Receipt ID: 1239 AUP 076 312

PRESTO!
Trace #: 078915
Reference #: 0982607250
Acct #: XXXXXXXXXXXX1264
Purchase American Express
Amount: \$63.89
Auth #: 893670

CREDIT CARD	PURCHASE
00000025010801	AMERICAN EXPRESS
Entry Method:	Cntct less
Mode:	Issuer

Your cashier was Karen H.

10/29/2024 15:33 S1239 R107 6312 C0225

Join the Publix family!
Apply today at apply.publix.jobs.
We're an equal opportunity employer.

Publix Super Markets, Inc.



Expense Report

ER-00606

Total
\$24.50

ONVIE REVERIE TRAILMARK EXP 11.5.24

Submitted By
Mackenzie Straley
mstraley@onplace.life

Report To
Erin Steele
esteele@onplace.life

Submitted On
06 Nov 2024

Report Duration
05 Nov 2024 - 05 Nov 2024

EXPENSE SUMMARY

S.No	Expense Details	Category	Amount (USD)
1.	06 Oct 2024 Merchant : EIG*CONSTANTCONTACT.CO Non Reimbursable Payment Mode : Credit Card Paid Through : Mackenzie - Cap1 - 3139 Project : OnVie Invoice Client : Yes Purchase Summary : Reverie TM monthly constant contact	Marketing (6140)	\$24.50

Submitted By

Approved By

Mackenzie Straley

Erin Steele



Print

Billing Activity - Invoices

Reverie TrailMark Lifestyle
Attn: Mackenzie Straley
50 Rustic Mill Dr. Street
St. Augustine FL 32092
US
P: 9415040852

Today's Date: 11/05/2024
User Name:

Invoices from 10/06/2024 to 11/05/2024

Date	Description	Charge Amount	Credit Amount
10/06/2024	Invoice #1728200134	\$24.50	

Billing questions? Contact Support

Constant Contact - 1601 Trapelo Road - Waltham, MA 02451 US



Expense Report

ER-00471

Total

\$55.00

Reverie at TrailMark 11.12.2024

Submitted By
Cassie Passantino
kpassantino@onplace.life

Report To
Erin Steele
esteele@onplace.life

Submitted On
12 Nov 2024

Report Duration
12 Nov 2024 - 12 Nov 2024

EXPENSE SUMMARY

S.No	Expense Details	Category	Amount (USD)
1.	10 Nov 2024 Merchant : Amazon Non Reimbursable Payment Mode : Credit Card Paid Through : Additional Business Expense Card on Business Platinum Customer : Dream Finders LLC [Non-Billable] Project : Reverie at Trailmark Homeowners Association, Inc. Invoice Client : Yes Event Name : Bingo Bash Event Date : 08 Nov 2024 Purchase Summary : Bingo Gift Cards	Event Expenses (6130)	\$55.00

Submitted By

Approved By

Cassie Passantino

Erin Steele

Final Details for Order #112-7705254-3869056

[Print this page for your records.](#)

Order Placed: November 10, 2024
Amazon.com order number: 112-7705254-3869056
Order Total: \$55.00

Gift Cards

Received	Amount
E-mail gift card to: Jambrosew62@gmail.com - From: Katharine Passantino - Message: Hope you enjoy this Amazon Gift Card!	\$10.00

Sent	Amount
E-mail gift card to: Joanw4life@hotmail.com - From: Katharine Passantino - Message: Hope you enjoy this Amazon Gift Card!	\$5.00

Sent	Amount
E-mail gift card to: jtcjr_2006@yahoo.com - From: Katharine Passantino - Message: Hope you enjoy this Amazon Gift Card!	\$5.00

Not yet sent	Amount
E-mail gift card to: sal.scavoa545@gmail.com - From: Katharine Passantino - Message: Hope you enjoy this Amazon Gift Card!	\$5.00

Received	Amount
E-mail gift card to: suem_stanfield@outlook.com - From: Katharine Passantino - Message: Hope you enjoy this Amazon Gift Card!	\$5.00

Sent	Amount
E-mail gift card to: carolb317@yahoo.com - From: Katharine Passantino - Message: Hope you enjoy this Amazon Gift Card!	\$5.00

Sent

E-mail gift card to: islandgirl60@aol.com

- **From:** Katharine Passantino

- **Message:**

Hope you enjoy this Amazon Gift Card!

Amount

\$5.00

Sent

E-mail gift card to: maxinebergman1963@yahoo.com

- **From:** Katharine Passantino

- **Message:**

Hope you enjoy this Amazon Gift Card!

Amount

\$5.00

Sent

E-mail gift card to: brez1249@gmail.com

- **From:** Katharine Passantino

- **Message:**

Hope you enjoy this Amazon Gift Card!

Amount

\$5.00

Sent

E-mail gift card to: snannyj1949@aol.com

- **From:** Katharine Passantino

- **Message:**

Hope you enjoy this Amazon Gift Card!

Amount

\$5.00

Payment information

Item(s) Subtotal: \$55.00

Total before tax: \$55.00

Estimated tax to be collected: \$0.00

Grand Total: \$55.00

Payment Method:

American Express | Last digits: 1284

To view the status of your order, return to Order Summary.

Please note: This is not a VAT invoice.

Conditions of Use | Privacy Notice © 1996-2024, Amazon.com, Inc. or its affiliates

Have an idea to help us improve? [Send feedback](#) ›

Get to Know Us

Careers

Blog

About Amazon

Let Us Help You

Customer Service

Shipping Rates &

Policies

Work with Amazon

Sell on Amazon Business

Sell on Amazon

Fulfillment By Amazon

Business Solutions

Amazon Business app

Amazon Business

Solutions

Buy For Your Business

Buy wholesale

Today's Deals

Buy Again

[Sustainability](#)

[Business FAQ](#)

[Advertise on Amazon](#)

[Manage Suppliers](#)

[PPE for Work](#)

[Press Center](#)

[Contact Us](#)

[Amazon Global Selling](#)

[Purchasing Systems](#)

[Request for quote](#)

[Investor Relations](#)

[Amazon Business Card](#)

[Amazon Devices](#)

[Pay by Invoice](#)

[Purchasing Line](#)

[Amazon Business Blog](#)



Scan the QR code to download the new Amazon Business app.



English

United States

[Alexa Actionable Analytics for the Web](#)

[Sell on Amazon Start a Selling Account](#)

[Amazon Marketing Services Self-service Advertising Solutions](#)

[Amazon Payments Login and Pay with Amazon](#)

[Amazon Web Services Scalable Cloud Computing Services](#)

[Mechanical Turk On-demand Scalable Workforce](#)

[Buy for Others Kindle eBook Bulk Buying Solution](#)

[Conditions of Use](#) [Privacy Notice](#) [Your Ads](#) [Privacy Choices](#)

© 1996-2024, Amazon.com, Inc. or its affiliates



Please Remit Payment to:
 23601 Laytonville Road
 Laytonville, MD 20882

INVOICE

Date	Invoice #
Nov 08,2024	683556

AP
 Six Mile Creek CDD
 6200 Lee Vista Boulevard
 Suite 300
 Orlando, FL 32822

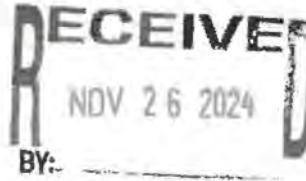

Agreement with:
 Six Mile Creek CDD
 6200 Lee Vista Boulevard
 Suite 300
 Orlando, FL 32822

Property Name	Terms	Due Date	Order Number
Six Mile Creek CDD /Reverie (261006)	Net30 Days	Dec 26 ,2024	3972005

QTY	Description	Price	Total
1	Reverie Bier Garden Install Pine straw from tree line to pond (800) bales Pine straw Delivery #SS 002-320-53800-46201 Received: 12/16/24 Approved: Matthew Reid CAM 	\$6,200.00	\$6,200.00

For billing questions contact Tel: 904-778-1030

For customer service contact Kyle Carasea Tel: 813-293-0587

Thank you for your business!

Subtotal:	\$6,200.00
Sales Tax:	\$0.00
Amount Due:	\$6,200.00

Payment by Check or ACH is preferred. Banking details supplied by request. Invoices paid by Credit Card will be subject to a 3% processing fee to cover incurred charges.



Please Remit Payment to:
 23601 Laytonville Road
 Laytonville, MD 20882

INVOICE

Date	Invoice #
Nov 08,2024	683557

AP
Six Mile Creek CDD
 6200 Lee Vista Boulevard
 Suite 300
 Orlando, FL 32822

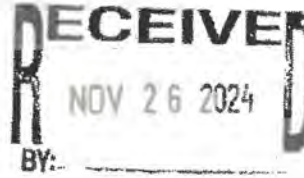

Agreement with:
Six Mile Creek CDD
 6200 Lee Vista Boulevard
 Suite 300
 Orlando, FL 32822

Property Name	Terms	Due Date	Order Number
Six Mile Creek CDD /Reverie (261006)	Net 30 Days	Dec 26,2024	3972008

QTY	Description	Price	Total
1	Reverie Bier Garden Landscape enhancement to clean out natural area from tree Line to Pond Labor Equipment \$\$\$ 002-320-53800-46200 Received: 12/16/24 Approved: Matthew Reid CAM	\$1,450.00	\$1,450.00



For billing questions contact Tel: 904-778-1030

For customer service contact Kyle Carasea Tel: 813-293-0587

Thank you for your business!

Subtotal:	\$1,450.00
Sales Tax:	\$0.00
Amount Due:	\$1,450.00

Payment by Check or ACH is preferred. Banking details supplied by request. Invoices paid by Credit Card will be subject to a 3% processing fee to cover incurred charges.



INVOICE

Please Remit Payment to:
 23601 Laytonsville Road
 Laytonsville, MD 20882

Date	Invoice #
Nov 08, 2024	683581

AP
 Six Mile Creek CDD
 6200 Lee Vista Boulevard
 Suite 300
 Orlando, FL 32822

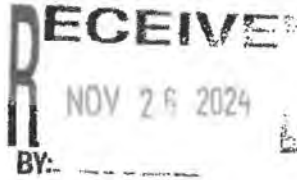

Agreement with:
 Six Mile Creek CDD
 6200 Lee Vista Boulevard
 Suite 300
 Orlando, FL 32822

Property Name	Terms	Due Date	Order Number
Reverie Amentiy Center (261008)	Net 30 Days	Dec 26, 2024	3989507

QTY	Description	Price	Total
1	Break at Amenity Center Zone 46 (1) 1" Zone line "T" (1) 12" Spray (1) Nozzle Labor \$\$\$ 002-320-53800-46300 Received: 12/16/24 Approved: Matthew Reid CAM	\$127.00	\$127.00



For billing questions contact Tel: 904-778-1030

For customer service contact Kyle Carasea Tel: 813-293-0587

Thank you for your business!

Subtotal:	\$127.00
Sales Tax:	\$0.00
Amount Due:	\$127.00

Payment by Check or ACH is preferred. Banking details supplied by request. Invoices paid by Credit Card will be subject to a 3% processing fee to cover incurred charges.



INVOICE

Date	Invoice #
Dec 20,2024	689409

Please Remit Payment to:
 23601 Laytonsville Road
 Laytonsville, MD 20882

AP
Six Mile Creek CDD
 6200 Lee Vista Boulevard
 Suite 300
 Orlando, FL 32822

#SS
 002-320-53800-46201
 Received: 12/23/24
 Approved: Matthew Reid CAM

Agreement with:
Six Mile Creek CDD
 6200 Lee Vista Boulevard
 Suite 300
 Orlando, FL 32822

Property Name	Terms	Due Date	Order Number
Six Mile Creek CDD /Reverie (261006)	Net 30 Days	Jan 20 2025	4016441

QTY	Description	Price	Total
1	Pull and plant New Annual Flowers at front entrance and Bier Garden (2286) 1 Qt Annual Flowers	\$6,515.00	\$6,515.00

For billing questions contact Tel: 904-778-1030

For customer service contact Kyle Carasea Tel: 813-293-0587

Thank you for your business!

Subtotal:	\$6,515.00
Sales Tax:	\$0.00
Amount Due:	\$6,515.00

Payment by Check or ACH is preferred. Banking details supplied by request. Invoices paid by Credit Card will be subject to a 3% processing fee to cover incurred charges.



INVOICE

Date	Invoice#
Dec 31,2024	690446

Please Remit Payment to:
 23601 Laytonsville Road
 Laytonsville, MD 20882



AP #55 2
 Six Mile Creek CDD 002-320-53800-46400
 6200 Lee Vista Boulevard Received: 12/30/24
 Suite 300 Approved: Matthew Reid CAM
 Orlando, FL 32822

Agreement with:
 Six Mile Creek CDD
 6200 Lee Vista Boulevard Suite 300
 Orlando, FL 32822

Property Name	Terms	Due Date	Order Number
Six Mile Creek CDD /Reverie (261006)	Net 30 Days	Jan 30,2025	

Description	Price	Total
Landscape Management For December As Per Contract, Due Jan 30, 2025	\$8,114.43	\$8,114.43

For billing questions contact Tel: 904-778-1030
 For customer service contact Kyle Carasea Tel: 813-293-0587

Subtotal:	\$8,114.43
Sales Tax:	\$0.00
Amount Due:	\$8,114.43

Thank you for your business!

Payment by Check or ACH is preferred. Banking details supplied by request. Invoices paid by Credit Card will be subject to a 3% processing fee to cover incurred charges.



INVOICE

Date	Invoice#
Dec 31,2024	690447

Please Remit Payment to:
23601 Laytonsville Road
Laytonsville, MD 20882

RECEIVED
 DEC 31 2024
 BY: _____

AP #SS 002-340-53800-46200
Six Mile Creek CDD Received: 12/30/24
 6200 Lee Vista Boulevard Approved: Matthew Reid CAM
 Suite 300
 Orlando, FL 32822

Agreement with:
Six Mile Creek CDD
 6200 Lee Vista Boulevard Suite 300
 Orlando, FL 32822

Property Name	Terms	Due Date	Order Number
Reverie <u>Amentiv</u> Center (261008)	Net 30 Days	Jan 30,2025	

Description	Price	Total
Landscape Management For December As Per Contract, Due Jan 30, 2025	\$2,737.07	\$2,737.07

For billing questions contact Tel: 904-778-1030
 For customer service contact Kyle Carasea Tel: 813-293-0587

Thank you for your business!

Subtotal:	\$2,737.07
Sales Tax:	\$0.00
Amount Due:	\$2,737.07

Payment by Check or ACH is preferred. Banking details supplied by request. Invoices paid by Credit Card will be subject to a 3% processing fee to cover incurred charges.



Pay by Phone (844) 752-8845
 Phone (904) 209-2700
 Fax (904) 209-2718
 Toll Free (877) 837-2311

PO Drawer 3006
 St. Augustine, FL 32085

Statement Date 12/19/2024	Current Charges Due Date 01/18/2025
-------------------------------------	---

Current Month Activity

Services Dates	Service Description	Units	Amount	Total
11/19/24	Amount of Your Last Statement			15.65
12/2/24	Payment - Thank You		-15.65	
	Past Due Balance			0.00
	Water Rates			
	Base Rate	15.45	1.00	15.45
Consumption Fees	0 - 5,000 Gallons	3.92	0.03	0.12
	Water Total		0.03	15.57
	Past Due Balance			0.00
	Current Charges			15.57
	Amount Now Due / Credits			15.57

SIX MILE CREEK CDD/TRAILMARK SUBDIVISION

Account Number:
556887-141819

Service Address:
255 RUSTIC MILL DR

Service Type:

Commercial

Days in Billing Cycle: 30

Deposit Amount: \$ 0.00

Deposit Date:

Geo Code: WGV

Meter Number: 89952575

Present Read Date: 12/19/2024

Previous Read Date: 11/19/2024

Current Reading: 635

Previous Reading: 632

Gallons Used: 30.00

#S
2-340-538431

Past Due Balances are subject to a Late Fee of 1.5% or \$5.00, whichever is greater and disconnection of service if not paid.

MESSAGE CENTER

In 2023, SJCUD detected 13 contaminants in the drinking water. All contaminants were at allowable levels & no health based violations were reported. Please go to www.sjcfi.us/WaterReport/NorthWest.pdf to view you report. This report contains important info about the source & quality of your water. To receive a hard copy of the report or if you have any questions please call 904-209-2700.

www.sjcutility.us

See reverse for monthly draft options or credit card payments.

Please detach and return with your payment.

FL29539F



ST JOHNS COUNTY UTILITY DEPARTMENT
 POST OFFICE DRAWER 3006
 ST AUGUSTINE FL 32085-3006

Account Number		Date Due	
556887-141819		01/18/2025	
Past Due Amount	Current Charges/Credits	Amount Now Due	After Due Date Pay
0.00	15.57	15.57	20.57
Please Enter Amount Paid \$		15.57	



Please write your account number on your check and remit to:

ST JOHNS COUNTY UTILITY DEPARTMENT
 POST OFFICE DRAWER 3006
 ST AUGUSTINE FL 32085-3006



SIX MILE CREEK CDD/TRAILMARK SUBDIVISION
 6200 LEE VISTA BLVD STE 300
 ORLANDO FL 32822-5149

000000141819000000556887000000001557000000002057

Check for Address Change



Pay by Phone (844) 752-8845
 Phone (904) 209-2700
 Fax (904) 209-2718
 Toll Free (877) 837-2311

PO Drawer 3006
 St. Augustine, FL 32085

SIX MILE CREEK CDD/TRAILMARK SUBDIVISION

Account Number:
 556887-144358

Service Address:
 35 RUSTIC MILL DR

Service Type:

Commercial

Days in Billing Cycle: 30

Deposit Amount: \$ 250.00

Deposit Date: 04/22/2022

Geo Code: WGV

Meter Number: 89442386

Present Read Date: 12/19/2024

Previous Read Date: 11/19/2024

Current Reading: 294359

Previous Reading: 271984

Gallons Used: 223,750.00

#S

2-340-528 431

Statement Date 12/19/2024	Current Charges Due Date 01/18/2025
-------------------------------------	---

Current Month Activity				
Services Dates	Service Description	Units	Amount	Total

11/19/24	Amount of Your Last Statement			4,135.52
12/2/24	Payment - Thank You		-4,135.52	
	Past Due Balance			0.00
	Water Rates			
	Meter Maintenance Charge	15.00	1.00	15.00
	Base Rate	231.61	1.00	231.61
Consumption Fees	0 - 75,000 Gallons	3.92	75.00	294.00
	75,001 - 150,000 Gallons	4.89	75.00	366.75
	150,001 - 300,000 Gallons	8.25	73.75	608.44
	Water Total		223.75	1,515.80
	Wastewater Rates			
	Base Rate	272.07	1.00	272.07
Consumption Fees	0 + Sewer Gallons	6.83	223.75	1,528.21
	Wastewater Total		223.75	1,800.28
	Past Due Balance			0.00
	Current Charges			3,316.08
	Amount Now Due / Credits			3,316.08

Past Due Balances are subject to a Late Fee of 1.5% or \$5.00, whichever is greater and disconnection of service if not paid.

MESSAGE CENTER

In 2023, SJCUD detected 13 contaminants in the drinking water. All contaminants were at allowable levels & no health based violations were reported. Please go to www.sjcfi.us/WaterReport/NorthWest.pdf to view you report. This report contains important info about the source & quality of your water. To receive a hard copy of the report or if you have any questions please call 904-209-2700.

www.sjcutility.us

See reverse for monthly draft options or credit card payments.

Please detach and return with your payment.

FL29539F



ST JOHNS COUNTY UTILITY DEPARTMENT
 POST OFFICE DRAWER 3006
 ST AUGUSTINE FL 32085-3006

Account Number		Date Due	
556887-144358		01/18/2025	
Past Due Amount	Current Charges/Credits	Amount Now Due	After Due Date Pay
0.00	3,316.08	3,316.08	3,365.82
Please Enter Amount Paid \$		3316.08	



Please write your account number on your check and remit to:

ST JOHNS COUNTY UTILITY DEPARTMENT
 POST OFFICE DRAWER 3006
 ST AUGUSTINE FL 32085-3006



SIX MILE CREEK CDD/TRAILMARK SUBDIVISION
 6200 LEE VISTA BLVD STE 300
 ORLANDO FL 32822-5149

000000144358000000556887000000331608000000336582

Check for Address Change

INVOICE

Sitex Aquatics, LLC
PO Box 917
Parrish, FL 34219

office@sitexaquatics.com
+1 (813) 564-2322



Bill to

Six Mile Creek c/o Reverie
6200 Lee Vista Boulevard,
Suite 300
Orlando, FL 32822

Ship to

Six Mile Creek c/o Reverie
6200 Lee Vista Boulevard,
Suite 300
Orlando, FL 32822

Invoice details

Invoice no.: 9410-B
Terms: Net 30
Invoice date: 01/01/2025
Due date: 01/31/2025



#	Date	Product or service	Description	Qty	Rate	Amount
1.		Aquatic Maintenance	<u>Monthly Lake Maintenance-Six Waterways</u>	1	\$1,164.00	\$1,164.00
Total						\$1,164.00

#13

002-320-53800-46400
Received: 1/2/25
Matthew Reid CAM



Staples
 ATTN: FSSC
 500 Staples Dr
 Framingham, MA 01702

Federal ID: 04-3390816



SIX MILE CREEK CDD
 Attention: TERESA VISCARRA
 475 W TOWN PLACE
 SUITE 114
 ST AUGUSTINE, FL 32092

Summary Number 7003566779

Invoice Number	Invoice Amount
6020753244	\$45.71
Invoice Date	Due Date
12/31/2024	01/30/2025
Order Number	Terms
7647344335-000-001	Net 30 Days
Bill To	Customer Account
@D24563	

Ordered By	Order Date
MATTHEW REID	12/06/2024
Deliver To	Approved By
MATTHEW REID	
Ship-to ID	
REVERIE	
Ship-to Name	
REVERIE AMENITY CENTER	

Detail Invoice

Budget Center BC Description

PO Number PO Description

PO Release PO Release Description

MATTHEW REID 12.6.24

Shipping Address

35 RUSTIC MILL DRIVE, ST. AUGUSTINE, FL, 32092

Line	Item Number	Description/LIBC	Cust SKU	UOM	Qty	Unit Price	Extended Price	Tax Amount	Total
1	897802	STAPLES COPY SELECT 20/94 CASE	897802	CT	1	\$45.71	\$45.71	\$0.00	\$45.71

#27

002-340-53800-51000
 Received: 1/1/25
 Approved: Matthew Reid CAM

Subtotal: \$45.71
Freight/Other: \$0.00
Tax (\$0.00%): \$0.00
Total: \$45.71

Please Remit All Payments To:	
ACH	Check
Wells Fargo Account: Routing: ARRemittance@Staples.com	Staples PO Box 70242 Philadelphia, PA 19176-0242



Staples
 ATTN: FSSC
 500 Staples Dr
 Framingham, MA 01702

Federal ID: 04-3390816

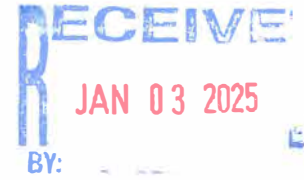

SIX MILE CREEK CDD
 Attention: TERESA VISCARRA
 475 W TOWN PLACE
 SUITE 114
 ST AUGUSTINE, FL 32092

Summary Number 7003566779

Invoice Number	Invoice Amount
6020753243	\$166.67
Invoice Date	Due Date
12/31/2024	01/30/2025
Order Number	Terms
7909327902-000-001	Net 30 Days
Bill To	Customer Account
@D24563	

Ordered By	Order Date
MATTHEW REID	12/09/2024
Deliver To	Approved By
MATTHEW REID	
Ship-to ID	
REVERIE	
Ship-to Name	
REVERIE AMENITY CENTER	

Detail Invoice

Budget Center	BC Description
PO Number	PO Description
PO Release	PO Release Description
MATTHEW REID 12.9.24	
Shipping Address	
35 RUSTIC MILL DRIVE,ST. AUGUSTINE,FL,32092	

Line	Item Number	Description/LIBC	Cust SKU	UOM	Qty	Unit Price	Extended Price	Tax Amount	Total
1	24398989	HP 414X HY BLACK LJ TNR CART	24398989	EA	1	\$166.67	\$166.67	\$0.00	\$166.67

#27
 002-340-53800-51000
 Received: 1/1/25
 Approved: Matthew Reid CAM

Subtotal: \$166.67
 Freight/Other: \$0.00
 Tax (\$0.00%): \$0.00
 Total: \$166.67

Please Remit All Payments To:	
ACH	Check
Wells Fargo Account: Routing: ARRemittance@Staples.com	Staples PO Box 70242 Philadelphia, PA 19176-0242

**TURNER WGV LLC
6205 STATE ROAD 16
ST. AUGUSTINE FL 32094**

PHONE: (904) 907-2424

CUST NO: 4055 JOB NO: 000 PURCHASE ORDER: REFERENCE: TERMS: NET 20TH CLERK: CSS DATE / TIME: 12/11/24 1:10

SOLD TO:
SIX MILE CREEK COMMUNITY
6200 Lee Vista Blvd, St 300

Orlando FL 32822
877-221-6919

SHIP TO:

DUE DATE: 1/20/25 TERMINAL: 405

TAX: WGV DEFAULT TAX CODE ST4

INVOICE: 9460 /4

SKU	MFG PART #	DESCRIPTION	SUGG	UNITS	PRICE /PER	EXTENSION
1590736	6200002	GORILLA WOOD GLUE 8OZ	6.99	1	6.99 EA	6.99 N
32886	MN1500B4Z	BATTERY ALKLN AA 4PK	6.99	2	6.99 EA	13.98 N

#30
002-340-53800-46000
Received: 12/16/24
Approved: Matthew Reid CAM

RECEIVED
JAN 03 2025
BY: _____

RECEIVED
DEC 11 2024
BY: _____

(BRIAN HYMAN)
** AMOUNT CHARGED TO STORE ACCOUNT **

TAXABLE 0.00
NON-TAXABLE 20.97
SUBTOTAL 20.97

TAX AMOUNT 0.00
TOTAL 20.97

TOT WT: 1.10

[Signature]
Received By

TURNER WGV LLC
 6205 STATE ROAD 16
 ST. AUGUSTINE FL 32094

PHONE: (904) 907-2424

CUST NO: 4055 JOB NO: 000 PURCHASE ORDER: REFERENCE: TERMS: NET 20TH CLERK: ACP DATE / TIME: 12/12/24 1:37

DUE DATE: 1/20/25 TERMINAL: 405

SOLD TO:
 SIX MILE CREEK COMMUNITY
 6200 Lee Vista Blvd, St 300

 Orlando FL 32822
 877-221-6919

SHIP TO:

TAX: WGV DEFAULT TAX CODE ST4

INVOICE: 9463 /4

SKU	MFG PART #	DESCRIPTION	SUGG	UNITS	PRICE /PER	EXTENSION
3011614	A1960CL927CAFL	FLMN LED A19 SW 9W 4PK #30 002-340-53800-46000 Received: 12/17/24 Approved: Matthew Reid CAM 	17.99	3	17.99 EA	53.97 N

TAXABLE 0.00
 NON-TAXABLE 53.97
 SUBTOTAL 53.97

(BRIAN HYMAN)
 ** AMOUNT CHARGED TO STORE ACCOUNT ** 53.97

TAX AMOUNT 0.00
TOTAL 53.97

TOT WT: 1.20

 Received By

#30

002-340-53800-47500
Received: 12/17/24
Approved: Matthew Reid CAM

TURNER WGV LLC
6205 STATE ROAD 16
ST. AUGUSTINE FL 32094

PAGE NO 1

PHONE: (904) 907-2424

CUST NO: 4055	JOB NO: 000	PURCHASE ORDER:	REFERENCE:	TERMS: NET 20TH	CLERK: ALH	DATE / TIME: 12/17/24 11:33
------------------	----------------	-----------------	------------	--------------------	---------------	--------------------------------

DUE DATE: 1/20/25 TERMINAL: 402

SOLD TO:
SIX MILE CREEK COMMUNITY
6200 Lee Vista Blvd, St 300

Orlando FL 32822
877-221-6919

SHIP TO:

TAX: ^{WGV} DEFAULT TAX CODE ST4

INVOICE: 9478 /4

SKU	MFG PART #	DESCRIPTION	SUGG	UNITS	PRICE /PER	EXTENSION
3004682	75S-200-8-UVC	CABLETIE 8"75# BLK 100PK	9.99	2	9.99 EA	19.98 N

RECEIVED
DEC 18 2024
BY: _____

(BRIAN HYMAN)
** AMOUNT CHARGED TO STORE ACCOUNT **

19.98

TAXABLE	0.00
NON-TAXABLE	19.98
SUBTOTAL	19.98

TAX AMOUNT 0.00

TOTAL	19.98
--------------	--------------

TOT WT: 0.60

x 

Received By

#30
 002-340-53800-46900
 Received: 12/20/24
 Approved: Matthew Reid CAM

TURNER WGV LLC
6205 STATE ROAD 16
ST. AUGUSTINE FL 32094

PHONE: (904) 907-2424

CUST NO: 4055 JOB NO: 000 PURCHASE ORDER: REFERENCE: TERMS: NET 20TH CLERK: APM DATE / TIME: 12/20/24 2:22

DUE DATE: 1/20/25 TERMINAL: 402

SOLD TO:
 SIX MILE CREEK COMMUNITY
 6200 Lee Vista Blvd, St 300

 Orlando FL 32822
 877-221-6919

SHIP TO:

TAX: WGV DEFAULT TAX CODE ST4

INVOICE: 9506 /4

SKU	MFG PART #	DESCRIPTION	SUGG	UNITS	PRICE /PER	EXTENSION
6038574	1652986	CONTRACTOR BAG 42G 20PK	16.99	2	16.99 EA	33.98 N

(BRIAN HYMAN)
 ** AMOUNT CHARGED TO STORE ACCOUNT **

33.98

TAXABLE 0.00
 NON-TAXABLE 33.98
 SUBTOTAL 33.98

TAX AMOUNT 0.00

TOTAL 33.98

TOT WT: 13.20

X 
 Received By

CommercialFitnessProducts

Invoice

5034 N Hiatus Road 954-747-5128 Phone
 Sunrise, FL 33351 954-747-5131 Fax

Date	Invoice #
1/6/2025	AC01057

Sold To	Ship To
---------	---------

Six Mile Creek CDD
 6200 Lee Vista Boulevard
 Suite 300
 Orlando, FL 32801

Reverie Amenity Center
 35 Rustic Mill Drive
 St Augustine, FL 32092

Rep	Account #	Sales Order No.	Ship Date	Purchase Order #	Terms	Due Date
MSM	SMC805	F09102474M	1/6/2025	Verbal	Net 30	2/5/2025
Qty	Item Code	Description		Price Each	Amount	
2	Athletix W	Equipment cleaning wipes - 4 rolls/case; 900 wipes/roll #8 002-340-53800-47500 Received: 1/13/25 Approved: Matthew Reid CAM		179.00	358.00	

Thank you for your business!

Total	\$358.00
Payments/Credits	\$0.00
Balance Due	\$358.00

www.commfitnessproducts.com



January 1, 2025
 Invoice No. 2501-RT

INVOICE

Prepared for Reverie at Trailmark
 50 Rustic Mill Dr. St Augustine FL 32092

DESCRIPTION OF WORK	STATIONS	VISITS	TOTAL
Servicing for - January <ul style="list-style-type: none"> • <u>Pet Waste Station Service</u> 	8 stations	1 X Week	\$482
#2 002-320-53800-47700 Received: 1/8/25 Approved: Matthew Reid			
		TOTAL	\$482
		PAID :	

Envera

8281 Blaikie Court
Sarasota, FL 34240
(941) 556-7066

002-340-53800-34500
Received: 1/7/25
Approved: Matthew Reid CAM



Invoice

Invoice Number 749657	Date 12/30/2024
Customer Number 300389	Due Date 02/01/2025

Page: 1

Customer Name	Customer Number	PO Number	Invoice Date	Due Date
Six Mile Creek CDD-The Reverie	300389		12/30/2024	02/01/2025

Quantity	Description	Months	Rate	Amount
1.00	Six Mile Creek CDD-The Reverie - Entrance, Pacetti Rd, Saint Augustine, FL Add Res as of 11/30/24 12/01/2024 - 01/31/2025	2.00	\$50.00	\$100.00
			Subtotal:	\$100.00
	Tax			\$0.00
	Payments/Credits Applied			\$0.00
			Invoice Balance Due:	\$100.00

MyEnvera Count as of 11/30/24. 5 additional homes @ \$10.00 each

Date	Invoice #	Description	Amount	Balance Due
12/30/2024	749657	Monitoring Services	\$100.00	\$100.00

Envera

8281 Blaikie Court
Sarasota, FL 34240
(941) 556-7066

Invoice

Invoice Number 749657	Date 12/30/2024
Customer Number 300389	Due Date 02/01/2025

Net Due: \$100.00
Amount Enclosed: \$100.00

Six Mile Creek CDD-The Reverie
6200 Lee Vista Blvd Ste 300
Orlando, FL 32822

REMIT TO: Envera
PO Box 2086
Hicksville, NY 11802

Envera

8281 Blaikie Court
Sarasota, FL 34240
(941) 556-7066
#4 2-300-155-1
002-340-53800-34500
Received: 1/7/25
Approved: Matthew Reid CAM



Invoice	
Invoice Number 750015	Date 01/02/2025
Customer Number 300389	Due Date 02/01/2025

Page: 1

Customer Name	Customer Number	PO Number	Invoice Date	Due Date
Six Mile Creek CDD-The Reverie	300389		01/02/2025	02/01/2025

Quantity	Description	Months	Rate	Amount
<i>2173 - Gate Access - Six Mile Creek CDD-The Reverie - Entrance, Pacetti Rd, Saint Augustine, FL</i>				
1.00	Service & Maintenance 02/01/2025 - 02/28/2025	1.00	\$321.62	\$321.62
1.00	Service & Maintenance 02/01/2025 - 02/28/2025	1.00	\$8.99	\$8.99
1.00	Envera Kiosk System 02/01/2025 - 02/28/2025	1.00	\$500.00	\$500.00
1.00	Data Management 02/01/2025 - 02/28/2025	1.00	\$200.00	\$200.00
1.00	Virtual Gate Guard Monitoring 02/01/2025 - 02/28/2025	1.00	\$2,700.00	\$2,700.00
Subtotal:				\$3730.61
Tax				\$0.00
Payments/Credits Applied				\$0.00
Invoice Balance Due:				\$3730.61

Date	Invoice #	Description	Amount	Balance Due
1/2/2025	750015	Monitoring Services	\$3730.61	\$3730.61

Envera

8281 Blaikie Court
Sarasota, FL 34240
(941) 556-7066

Invoice	
Invoice Number 750015	Date 01/02/2025
Customer Number 300389	Due Date 02/01/2025

Net Due: \$3,730.61

Amount Enclosed: \$3730.61

Six Mile Creek CDD-The Reverie
6200 Lee Vista Blvd Ste 300
Orlando, FL 32822

REMIT TO:
Envera
PO Box 2086
Hicksville, NY 11802

INVOICE

FASTJAXTRIVIA.com

Jacksonville's Best Trivia Shows!

REVERIE
JAN 16 2025

Show: Reverie At TrailMark, 35 Rustic Mill Drive, St. Augustine, FL 32092

Date of Service: Friday, January 10, 2025

Service Provided: Bingo Facilitator

Payment Due: \$275.00

#68
2-24058432

Mailing address:

Fast Jax Trivia

1119 Romaine Circle East

Jacksonville, FL 32225

(904) 233-7792

Billed To: Six Mile Creek CDD

Billing Address: 475 W. Town Place, Suite 114, St. Augustine, FL 32092

INVOICE

FASTJAXTRIVIA.com

Jacksonville's Best Trivia Shows!



Show: Reverie At TrailMark, 35 Rustic Mill Drive, St. Augustine, FL 32092

Date of Service: Friday, November 15, 2024

Service Provided: Trivia Facilitator

Payment Due: \$275.00

#68
2-340-538 LTR

Mailing address:

Fast Jax Trivia

1119 Romaine Circle East

Jacksonville, FL 32225

(904) 233-7792

Billed To: Six Mile Creek CDD

Billing Address: 475 W. Town Place, Suite 114, St. Augustine, FL 32092

INVOICE

FASTJAXTRIVIA.com

Jacksonville's Best Trivia Shows!



Show: Reverie At TrailMark, 35 Rustic Mill Drive, St. Augustine, FL 32092

Date of Service: Friday, December 13, 2024

Service Provided: Trivia Facilitator

Payment Due: \$285.00

#65
2-340-378-432

Mailing address:

Fast Jax Trivia

1119 Romaine Circle East

Jacksonville, FL 32225

(904) 233-7792

Billed To: Six Mile Creek CDD

Billing Address: 475 W. Town Place, Suite 114, St. Augustine, FL 32092

Gary Whitaker
131 Seasons Court
St Augustine FL 32092
914 - 443 - 9115
djgary22@hotmail.com



www.strictlyentertainmentdjs.com

This agreement shall cover the disc jockey performance at the following affair:

Date Of Event: Friday February 7, 2025

Type Of Event: Musical Bingo #33
2-200-1551

Hours Of Music: 7:00 - 8:30

Additional services: N/A

Location Of Event: Reverie at Trailmark

Client (s) Name: Six Mile Creek CDD / Reverie at Trailmark

Address: 475 W. Town Place, Suite 114, St Aug, FL, 32092

Phone number:

Email address: hello@reverietrailmarklife.com

Deposit: None - Non refundable and all personal checks or money orders are made payable to "Gary Whitaker" only.

Balance: \$200.00 —The Balance is due on February 7, 2025 and must be in the form of a check, US money order or cash and all checks or money orders are made payable to "Gary Whitaker".

Guest Total:

Overtime rate: - \$100.00 per hour (if available)

Additional Information:

D.J. Gary Whitaker

Date: 1/10/2025

Client: _____

Date: _____

Please return (1) copy of contract and deposit by the date of _____ to secure date*****

Municipal Asset Management, Inc.

25288 Foothills Drive North
Suite 225
Golden, CO 80401
(303) 273-9494

INVOICE

INVOICE NO: 0619402
DATE: 1/15/2025

To: Six Mile Creek Community Development Dist
Teresa Viscarra
475 West Town Place, Suite 114
St. Augustine, FL 32092



DUE DATE	RENTAL PERIOD
2/27/2025	

PMT NUMBER	DESCRIPTION	AMOUNT
25	Lease payment for Tax-Exempt Lease Purchase Agreement dated July 20, 2022 for the purchase of <u>fitness</u> equipment #31 310-517-71 - 81946182 310-517-72 - 523402	2,278.89

TOTAL DUE \$2,278.89

Please detach coupon and return with check payable to MUNICIPAL ASSET MANAGEMENT, INC. and remit to address above.

If you have any questions concerning this invoice,
call: Municipal Asset Management, Paul Collings, (303) 273-9494.

THANK YOU FOR YOUR BUSINESS!

Invoice #	Due Date	Total Due	Amount Enclosed
0619402	2/27/2025	\$2,278.89	\$2,278.89

Six Mile Creek Community Development Dist
Teresa Viscarra
475 West Town Place, Suite 114
St. Augustine, FL 32092

Municipal Asset Management, Inc.
25288 Foothills Drive North
Suite 225
Golden, CO 80401

Service Slip/Invoice



MCCALL SERVICE
 PO BOX 600730
 JACKSONVILLE, FL 32260-0730
 800-342-6948

INVOICE: 59420321
DATE: 01/09/2025
ORDER: 59420321

Bill To: [77002840]
 SIX MILE CREEK EAST PARCEL
 35 RUSTIC MILL DR
 ST. AUGUSTINE, FL 32092-7940

Work Location: [77002840] 904-504-5882
 SIX MILE CREEK EAST PARCEL
 35 RUSTIC MILL DR
 ST AUGUSTINE, FL 32092

Work Date	Time	Target Pest	Technician		Time In
01/09/2025	02:12 PM		ADDOYLE	Aaron Doyle	02:12 PM
Purchase Order	Terms	Last Service	Map Code		Time Out
	NET 30	01/09/2025			02:50 PM

Service	Description	Price
---------	-------------	-------

FL COMM PM	FL COMMERCIAL PEST MGMT	\$75.00
------------	-------------------------	---------

It was a pleasure speaking with you today! I checked in with Matt in the office, there was no pest issues at this time, I proceeded to treat the exterior of the building. I swept down all spiderwebs and wasp nests within reach, I then applied a liquid residual on the exterior structure including all entry points, I then applied a granular insect bait in the ornamental areas including the tennis courts to further fortify from occasional pests. If you have any questions please feel free to give us a call! Thank you for choosing McCall Service.
 Aaron Doyle

SUBTOTAL	\$75.00
TAX	\$0.00
AMT. PAID	\$0.00
TOTAL	\$75.00

#22
 002-340-53800-46800
 Received: 1/15/25
 Approved: Matthew Reid CAM



AMOUNT DUE \$75.00

AD

TECHNICIAN SIGNATURE

CUSTOMER SIGNATURE

Balance outstanding over 30 days from the date of service may be subject to a late fee of the lesser of 1.5% per month (18% per year) or the maximum allowed by law. Customer agrees to pay accrued expenses in the event of collection.

Flurry 24mm Insecticide satisfactory completion of all services required. Customer to pay for cost of services as specified above.

REVERIE

AT TRAILMARK

Service Address:
 Reverie at Trailmark
 35 Rustic Mill Drive
 St. Augustine, FL 32092

Invoice Number: 11026932
Invoice Date: 1/15/2025
Terms: Net 30
Period Begin: 11/30/2024
Period End: 12/13/2024
Reverie: 100-OSPU

BILLING ADDRESS:
 FS Residential
 1601 SW 80th Terrace, Plantation, FL, 33324
 GL CODE 41011-00

Customer:
 Six Mile Creek CDD - Reverie
 475 West Town Place, Ste 114
 St. Augustine, FL 32092



Staff Reverie (East Parcel) Total Amount Due: \$5,493.23

Position title # 23	Employee	Percentage	Type Hours	Hours Per Pay Period	Pay Rate	Amount
					Per hour	
Field Operations Mgmt 2-220538121	Matthew Reid	10%	REG	80	\$38.46	\$384.62
			Phone		\$70.00	\$70.00
				80.00		\$454.62
Administrator, On-Site Property 2-34058121	Paula Linge	100%	REG	78.95	\$20.60	\$2,032.98
			OT	1	\$30.90	\$38.63
				79.95		\$2,071.61
Field Mgmt/Admin 2-320578121	Brian Hyman	100%	REG	80	\$24.00	\$2,592.00
			AUTO		\$300.00	\$300.00
			PHONE		\$75.00	\$75.00
				80		\$2,967.00
	Subtotal					\$5,493.23
	Tax					\$0.00
	Total					\$5,493.23

Approved by CAM:

Matthew Reid

1/15/2025

REVERIE

AT TRAILMARK

Service Address:
 Reverie at Trailmark
 35 Rustic Mill Drive
 St. Augustine, FL 32092

Invoice Number: 11028635
Invoice Date: 1/16/2025
Terms: Net 30
Period Begin: 12/1/2024
Period End: 12/31/2024
Reverie: 100-OSPU

BILLING ADDRESS:
 FS Residential
 1601 SW 80th Terrace, Plantation, FL, 33324
 GL CODE 41011-00



Customer:
 Six Mile Creek CDD - Reverie
 475 West Town Place, Ste 114
 St. Augustine, FL 32092

Staff Reverie (East Parcel)

Total Amount Due: \$726.00

Medical Insurance

Position title	Employee	Percentage			Amount
Field Mgmt/Admin #23 2-320-51% 122	Brian Hyman	100%		December	\$726.00
					\$726.00
	Subtotal				\$726.00
	Tax				\$0.00
	Total				\$726.00

Approved by CAM:

Matthew Reid

1/16/2025

Reverie at Trailmark

INVOICE

Homeowners Association, Inc.

c/o FirstService Residential
1601 SW 80th Terrace
Plantation, FL 33324

DATE: 1/16/25
INVOICE # 1333PR-3

Bill To:
Six Mile Creek Community Development District
475 West Town Place, Suite 114
St. Augustine, FL 32092



DESCRIPTION	AMOUNT
Lifestyle Director Payroll Reimbursement Cassie Passantino Pre-Pay Passthrough Payroll (January - 3 Pay Periods, February - 2 Pay Periods) #23 2-340598.12	\$ 15,000.00
Terms: Net 30 Days	
TOTAL	\$ 15,000.00

THANK YOU FOR YOUR BUSINESS!

Dream Finders Reverie at Trailmark
Payroll Reconciliation
Gross Payroll + 30% Burden



10/25/2024	<u>\$3,000.40</u>	October 4 - October 18
	-\$3,000.40	Payroll Balance due
11/8/2024	<u>\$3,000.40</u>	October 19 - November 1
	-\$6,000.80	Payroll balance due
11/21/2024	<u>6000.00</u>	Payment (INV 1241)
	-\$0.80	Payroll balance due
11/22/2024	<u>\$3,450.5</u>	November 2 - November 15
	-\$3,451.31	Payroll balance due
12/6/2024	<u>\$3,037.91</u>	November 16 - November 29
	-\$6,489.22	Payroll Balance due
12/18/2024	<u>\$12,000.00</u>	Payment (INV 1306)
	\$5,510.78	Remaining Payroll Credit
12/18/2024	<u>\$15,000.00</u>	Payment (INV 1333)
	\$20,510.78	Remaining Payroll Credit
12/20/2024	<u>\$3,000.01</u>	November 30 - December 13
	\$17,510.77	Remaining Payroll Credit
1/3/2025	<u>\$3,000.01</u>	December 14 - December 27
	\$14,510.76	Remaining Payroll Credit
1/17/2025	<u>\$3,000.01</u>	December 28, 2024 - January 10, 2025
	\$11,510.75	Remaining Payroll Credit

Reverie at Trailmark Homeowners Association

c/o FirstService Residential
 1601 SW 80th Terrace
 Plantation, FL 33324



Invoice Number: 1413CCR-5
Date: 1/16/2025

Bill To:
 Six Mile Creek Community Development District
 475 West Town Place, Suite 114
 St. Augustine, FL 32092

Description	GL Code	Category	Store/vendor	Amount	
ER-00557					
12/24 Ornaments for The Retreat Christmas Tree	002-340-53800-47200	6130	Hobby Lobby	\$25.53	✓
Fruit for Break from the Grind	002-340-53800-47200	6130	Publix	\$19.83	✓
Food items for Break from the Grind	002-340-53800-47200	6130	Dunkin'	\$112.44	✓
Supplies for Deck the Tree Workshop	002-340-53800-47200	6130	Party City	\$5.07	✓
					\$162.87
ER-00576					
Gift Cards for trivia Tacky Trivia Bash	002-340-53800-47200	6130	Amazon	\$80.00	✓
Food items for New Resident Social	002-340-53800-47200	6130	Publix	\$94.76	✓
Decor for Coastal winter wonderland	002-340-53800-47200	6130	Amazon	\$143.59	✓
Food and Supplies for Wine Down Wednesday	002-340-53800-47200	6130	Publix	\$146.25	✓
Toast to the New Year items	002-340-53800-47200	6130	Amazon	\$243.49	✓
Toast to the New Year items	002-340-53800-47200	6130	Amazon	\$108.78	✓
Coastal Winter Wonderland items	002-340-53800-47200	6130	Target	\$154.59	✓
Items for minute to win it challenges	002-340-53800-47200	6130	Walmart	\$104.42	✓
					\$1,075.88
ER-00653					
Monthly constant contact fee	002-340-53800-54000	6140	OnPlace	\$35.00	✓
ER-00606					
Supplies for Coastal Winter Wonderland	002-340-53800-47200	6130	Party City	\$31.68	✓
Supplies for Coastal Winter Wonderland	002-340-53800-47200	6130	Publix	\$165.92	✓
To-go boxes for Holiday Sweet Swap	002-340-53800-47200	6130	Amazon	\$36.67	✓
Supplies for Holiday Sweet Swap	002-340-53800-47200	6130	Publix	\$44.47	✓
Party favors for A Toast to the New Year	002-340-53800-47200	6130	Party City	\$125.22	✓
Plastic bins for organization	002-340-53800-51000	6130	Walmart	\$72.10	✓
Cups, napkins, utensils, drinks for A Toast to the New Year	002-340-53800-47200	6130	Publix	\$190.21	✓
Duct Tape for Lifestyle	002-340-53800-51000	6130	Walgreens	\$17.02	✓
Decor for A Toast to the New Year	002-340-53800-47200	6130	Hobby Lobby	\$44.84	✓
Table decor for A Toast to the New Year	002-340-53800-47200	6130	Michaels	\$55.35	✓
Party decor for A Toast to the New Year	002-340-53800-47200	6130	Party City	\$54.50	✓
Food items for A Toast to the New Year	002-340-53800-47200	6130	Publix	\$309.34	✓
Vases for A Toast to the New Year	002-340-53800-47200	6130	Dollar Tree	\$11.98	✓
1/23 Coffee creamer for coffee station in The Retreat	002-340-53800-51000	6130	Amazon	\$27.98	✓
1 USB for Lifestyle Photos in Lobby	002-340-53800-51000	6130	Amazon	\$12.77	✓
					\$1,200.05
			Subtotal	\$2,473.80	
	2-740838.491	(Credit proc. fee)	10% fee	\$247.38	
			Grand Total:	\$2,721.18	

Terms: Net 30 Days

THANK YOU FOR YOUR BUSINESS!

INVOICE

OnVie LLC

6801 Energy Ct Ste 201
Lakewood Ranch, FL 34240

hello@onvie.life
+1 (941) 706-2637
www.onvie.life



Dream Finders LLC: The Reverie Homeowners' Association, Inc.

Bill to

THE REVERIE HOMEOWNERS'
ASSOCIATION, INC. (OSPU)

c/o FirstService Residential
P.O. Box 34769
Charlotte, NC 28234

Ship to

THE REVERIE HOMEOWNERS'
ASSOCIATION, INC. (OSPU)

c/o FirstService Residential
P.O. Box 34769
Charlotte, NC 28234

Invoice details

Invoice no.: 1413
Terms: Net 5
Invoice date: 01/14/2025
Due date: 01/19/2025

#	Date	Product or service	Description	Qty	Rate	Amount
1.	01/14/2025	Credit Card Processing Fee	10% Credit Processing Fee	1	\$247.38	\$247.38
2.	01/14/2025	Programming + Event Expenses	Event Programming (Dec - January)	1	\$2,473.80	\$2,473.80

Total

\$2,721.18

Contact OnVie to pay.



Expense Reimbursements

Client: THE REVERIE HOMEOWNERS' ASSOCIATION, INC.
Date: 1.14.25
Period: 12.12-01.14.25
Entity: 0SPU

ER-00557	\$	162.87
ER-00576	\$	1,075.88
ER-00653	\$	35.00
ER-00606	\$	1,200.05
Total	\$	2,473.80
10% Fee	\$	247.38
Total	\$	2,721.18



Expense Report

ER-00557

Total

\$162.87

Reverie at TrailMark 12.17.2024

Submitted By
Cassie Passantino
kpassantino@onplace.life

Report To
Erin Steele
esteele@onplace.life

Submitted On
17 Dec 2024

Report Duration
17 Dec 2024 - 17 Dec 2024

EXPENSE SUMMARY

S.No	Expense Details	Category	Amount (USD)
1.	10 Dec 2024 Merchant : Hobby Lobby Non Reimbursable Payment Mode : Credit Card Paid Through : Additional Business Expense Card on Business Platinum Customer : Dream Finders LLC (Non-Billable) Project : DreamFinders Invoice Client : Yes Event Name : Ornaments for The Retreat Christmas Tree Event Date : 17 Dec 2024 Purchase Summary : Ornaments for The Retreat Christmas Tree	Event Expenses (6130)	\$25.53

2.	<p>11 Dec 2024 Merchant : Publix Non Reimbursable</p> <p>Payment Mode : Credit Card Paid Through : Additional Business Expense Card on Business Platinum Customer : Dream Finders LLC (Non-Billable) Project : DreamFinders Invoice Client : Yes Event Name : Break from the Grind Event Date : 11 Dec 2024 Purchase Summary : Fruit for Break from the Grind</p>	Event Expenses (6130)	\$19.83
3.	<p>12 Dec 2024 Merchant : Dunkin' Non Reimbursable</p> <p>Payment Mode : Credit Card Paid Through : Additional Business Expense Card on Business Platinum Customer : Dream Finders LLC (Non-Billable) Project : DreamFinders Invoice Client : Yes Event Name : Break from the Grind Event Date : 11 Dec 2024 Purchase Summary : Food items for Break from the Grind</p>	Event Expenses (6130)	\$112.44
4.	<p>15 Dec 2024 Merchant : Party City Non Reimbursable</p> <p>Payment Mode : Credit Card Paid Through : Additional Business Expense Card on Business Platinum Customer : Dream Finders LLC (Non-Billable) Project : DreamFinders Invoice Client : Yes Event Name : Deck the Tree Workshop Event Date : 14 Dec 2024 Purchase Summary : Supplies for Deck the Tree Workshop</p>	Event Expenses (6130)	\$5.07

Submitted By

Approved By

Cassie Passantino

Erlin Steele

HOBBY LOBBY

Super Savings, Super Selection!

200 State Road 312

St. Augustine, FL 32086
Hobby Lobby Store #226 (904) 810-1001

S:226 R-1 I-3938 MADISON T. SALE

104000000	Christmas	9.99
Promo 50% Off (19.98-9.99)		
104000000	Christmas	12.99
Promo 50% Off (25.98-12.99)		
104000000	Christmas	0.99
Promo 50% Off (1.99-1.00)		

SUBTOTAL	23.97
TAX TOTAL	1.56
TOTAL	25.53

AMEX 25.53

ACCOUNT #: *****1284
AUTH#: 897870
ACCT: AMEX. INSERTED
CARD # *****1284 EXP **/**
REF # AUTH # RESP 00
175912091042 897870 ISO 00
AID: A00000025010801
TSI: E800 ARC: CUR: (840)
TVR: 0000008000
APP: AMERICAN EXPRESS
IAD: 06650103A03002

No Signature
CHANGE DUE 0.00

Number of Items Purchased: 3

Total savings: 23.98

Thank You. Please come again.
Become a fan on Facebook.
Sign up today for our Hobby Lobby App.

Visit our website at www.hobbylobby.com



0226001039381209248

12/9/24 05:57 PM

RETURN POLICY

Hobby Lobby values customer satisfaction,
with or without the receipt

WITH ORIGINAL SALES RECEIPT.
Within 90 days of purchase, we will gladly exchange the
merchandise, give a store credit, or issue a refund based on

Publix

Cobblestone Plaza
125 Jenkins St.
St. Augustine, FL 32086
Store Manager: Meredith Pearson
904-808-9929

FRUIT SALAD LARGE 19.83 F
You Saved 0.82
Order Total 19.83
Sales Tax 0.00
Grand Total 19.83
Credit Payment 19.83
Change 0.00

Savings Summary

Special Price Savings 0.82

* Your Savings at Publix *
* 0.82 *

Receipt ID: 0099 CAP 750 222

PREST01
Trace #: 753159
Reference #: 1092593518
Acct #: XXXXXXXXXXXX1284
Purchase American Express
Amount: \$19.83
Auth #: 836158

CREDIT CARD PURCHASE
A00000025010801 AMERICAN EXPRESS
Entry Method: Contactless
Mode: Issuer

Your cashier was Self-Checkout Lane 1
12/10/2024 17:27 S0099 R175 0222 00775

Join the Publix family!
Apply today at apply.publix.jobs.
We're an equal opportunity employer.

Publix Super Markets, Inc.



Welcome to Dunkin'
Store #: 364218
40 Epic Boulevard
Saint Augustine, FL 32084
654560 Dunkin'

CHK 3638
12/11/2024 8:21 AM

Eat In

1 50 Munchkins	13.99
2 12 Donuts	27.98
2 Box Hot Orig Cof	46.98
1 Box Hot Decaf Cof	23.49
American Express	\$112.44
*****1284	

Tran Type : Purchase
Entry Mode : INSERTED
Auth Code : 847654
AMERICAN EXPRESS
AID: A00000025010801
No Signature Required
I agree to pay the above total
amount according to the card
issuer
(merchant agreement if credit
voucher)

Subtotal	\$112.44
Payment	\$112.44
Change Due	\$0.00

----- Check Closed -----
12/11/2024 8:23 AM

Donut forget to tell us about
today's visit! Talk to us at
www.DunkinRunsOnYou.com
within 3 days and receive a
FREE CLASSIC DONUT
on your next visit when you
purchase a Medium or Larger Beverage
See restrictions on dunkindonuts.com

Survey Code: 63801-64218-0812-1146

Additional Discounts Will Not Be
Applied to Promotional Offers

Thank You. Come Back Again.
Additional Discounts Will Not Be
Applied to Promotional Offer

Check # 3638
Total Items: 6

Party City

NOBODY HAS MORE PARTY FOR LESS

440 CBL DRIVE, SUITE 101
SAINT AUGUSTINE, FL 32086
904-640-8151

048419497011 54X108IN RED	\$1.49	/
54x108IN RED TC PLSTC		
ORIG PRICE (\$1.49 ea)		
PROMO DISCOUNT	\$0.30	-
048419497011 54X108IN RED	\$1.49	/
54x108IN RED TC PLSTC		
ORIG PRICE (\$1.49 ea)		
PROMO DISCOUNT	\$0.30	-
048419497011 54X108IN RED	\$1.49	/
54x108IN RED TC PLSTC		
ORIG PRICE (\$1.49 ea)		
PROMO DISCOUNT	\$0.30	-
048419497011 54X108IN RED	\$1.49	/
54x108IN RED TC PLSTC		
ORIG PRICE (\$1.49 ea)		
PROMO DISCOUNT	\$0.30	-

SUBTOTAL	49.76
GEN MERCH TAX @ 5.00%	2.49
TOTAL	52.25
CR AMEX	52.25
ITEMS * 4	YOU SAVED \$1.20

XXXXXXXXXX1284 CHIP

APP# 872536

Application Label: AMERICAN EXPRESS

AC: 4388245A5C308800

TVR: 0000008000

AID: A00000025010801

TST: F800

ARC: 00

STORE 914 TRN 9 REG 3
12-14-2024 09:26:52 AM

1E2 116D 003 009M



1E2116D003009M

All returns & exchanges require
an original receipt dated within
30 days of purchase or email to
look up receipt & must be
in original packaging with all
components in unused condition
or have manufacturer defect
Seasonal items may be returned
up to 7 days prior to holiday.



Expense Report

ER-00576

Total

\$1,075.88

Reverie at TrailMark 12.23.2024

Submitted By
Cassle Passantino
kpassantino@onplace.life

Report To
Erin Steele
esteele@onplace.life

Submitted On
23 Dec 2024

Report Duration
23 Dec 2024 - 23 Dec 2024

EXPENSE SUMMARY

S.No	Expense Details	Category	Amount (USD)
1.	17 Dec 2024 Merchant : Amazon Non Reimbursable Payment Mode : Credit Card Paid Through : Additional Business Expense Card on Business Platinum Customer : Dream Finders LLC (Non-Billable) Project : DreamFinders Invoice Client : Yes Event Name : Tacky Trivia Bash Event Date : 13 Dec 2024 Purchase Summary : Gift Cards for trivia	Event Expenses (6130)	\$80.00

2.	<p>17 Dec 2024 Merchant : Publix Non Reimbursable</p> <p>Payment Mode : Credit Card Paid Through : Additional Business Expense Card on Business Platinum Customer : Dream Finders LLC (Non-Billable) Project : DreamFinders Invoice Client : Yes Event Name : New Resident Social Event Date : 16 Dec 2024 Purchase Summary : Food items for New Resident Social</p>	Event Expenses (6130)	\$94.76
3.	<p>18 Dec 2024 Merchant : Amazon Non Reimbursable</p> <p>Payment Mode : Credit Card Paid Through : Additional Business Expense Card on Business Platinum Customer : Dream Finders LLC (Non-Billable) Project : DreamFinders Invoice Client : Yes Event Name : Coastal Winter Wonderland Event Date : 21 Dec 2024 Purchase Summary : Decor for Coastal winter wonderland</p>	Event Expenses (6130)	\$143.59
4.	<p>19 Dec 2024 Merchant : Publix Non Reimbursable</p> <p>Payment Mode : Credit Card Paid Through : Additional Business Expense Card on Business Platinum Customer : Dream Finders LLC (Non-Billable) Project : DreamFinders Invoice Client : Yes Event Name : Wine Down Wednesday Event Date : 18 Dec 2024 Purchase Summary : Food and Supplies for Wine Down Wednesday</p>	Event Expenses (6130)	\$146.25
5.	<p>20 Dec 2024 Merchant : Amazon Non Reimbursable</p> <p>Payment Mode : Credit Card Paid Through : Additional Business Expense Card on Business Platinum Customer : Dream Finders LLC (Non-Billable) Project : DreamFinders Invoice Client : Yes Event Name : Toast to the New Year Event Date : 31 Dec 2024 Purchase Summary : Items for Toast to the New Year</p>	Event Expenses (6130)	\$243.49

6.	<p>21 Dec 2024 Merchant : Amazon Non Reimbursable</p> <p>Payment Mode : Credit Card Paid Through : Additional Business Expense Card on Business Platinum Customer : Dream Finders LLC (Non-Billable) Project : DreamFinders Invoice Client : Yes Event Name : Toast to the New Year Event Date : 31 Dec 2024 Purchase Summary : Items for Toast to the New Year</p>	Event Expenses (6130)	\$108.78
7.	<p>21 Dec 2024 Merchant : Target Non Reimbursable</p> <p>Payment Mode : Credit Card Paid Through : Additional Business Expense Card on Business Platinum Customer : Dream Finders LLC (Non-Billable) Project : DreamFinders Invoice Client : Yes Event Name : Coastal Winter Wonderland Event Date : 21 Dec 2024 Purchase Summary : Items for Coastal Winter Wonderland</p>	Event Expenses (6130)	\$154.59
8.	<p>21 Dec 2024 Merchant : Walmart Non Reimbursable</p> <p>Payment Mode : Credit Card Paid Through : Additional Business Expense Card on Business Platinum Customer : Dream Finders LLC (Non-Billable) Project : DreamFinders Invoice Client : Yes Event Name : Coastal Winter Wonderland Event Date : 21 Dec 2024 Purchase Summary : Items for minute to win it challenges</p>	Event Expenses (6130)	\$104.42

Submitted By

Approved By

Cassie Passantino

Erin Steele

Final Details for Order #112-3248056-3947449

[Print this page for your records.](#)

Order Placed: December 17, 2024
Amazon.com order number: 112-3248056-3947449
Order Total: \$80.00

Gift Cards

Received	Amount
E-mail gift card to: s.shannon148@comcast.net - From: Katharine Passantino - Message: Hope you enjoy this Amazon Gift Card!	\$10.00

Received	Amount
E-mail gift card to: nhall8286@gmail.com - From: Katharine Passantino - Message: Hope you enjoy this Amazon Gift Card!	\$10.00

Not yet sent	Amount
E-mail gift card to: jnicks2717@aol.com - From: Katharine Passantino - Message: Hope you enjoy this Amazon Gift Card!	\$10.00

Received	Amount
E-mail gift card to: jnicks2712@aol.com - From: Katharine Passantino - Message: Hope you enjoy this Amazon Gift Card!	\$10.00

Sent	Amount
E-mail gift card to: scottnami@gmail.com - From: Katharine Passantino - Message: Hope you enjoy this Amazon Gift Card!	\$10.00

Sent	Amount
E-mail gift card to: scottnami@gmail.com - From: Katharine Passantino - Message: Hope you enjoy this Amazon Gift Card!	\$10.00

Sent

E-mail gift card to: rodeo1974@comcast.net

- **From:** Katharine Passantino

- **Message:**

Hope you enjoy this Amazon Gift Card!

Amount

\$5.00

Sent

E-mail gift card to: catheyy@yahoo.com

- **From:** Katharine Passantino

- **Message:**

Hope you enjoy this Amazon Gift Card!

Amount

\$5.00

Sent

E-mail gift card to: catheyy@yahoo.com

- **From:** Katharine Passantino

- **Message:**

Hope you enjoy this Amazon Gift Card!

Amount

\$5.00

Not yet sent

E-mail gift card to: rodeo1974@comcast.com

- **From:** Katharine Passantino

- **Message:**

Hope you enjoy this Amazon Gift Card!

Amount

\$5.00

Payment information

Item(s) Subtotal: \$80.00

Total before tax: \$80.00

Estimated tax to be collected: \$0.00

Grand Total: \$80.00

Payment Method:

American Express | Last digits: 1284

To view the status of your order, return to Order Summary.

Please note: This is not a VAT invoice.

Conditions of Use | Privacy Notice © 1996-2024, Amazon.com, Inc. or its affiliates

Have an idea to help us improve? Send feedback

Get to Know Us

Careers

Blog

About Amazon

Let Us Help You

Customer Service

Shipping Rates & Policies

Work with Amazon

Sell on Amazon Business

Fulfillment By Amazon

Advertise on Amazon

Business Solutions

Amazon Business app

Amazon Business Solutions

Buy For Your Business

Buy wholesale

Today's Deals

Buy Again

[Sustainability](#)

[Business FAQ](#)

[Amazon Global Selling](#)

[Manage Suppliers](#)

[PPE for Work](#)

[Press Center](#)

[Contact Us](#)

[Purchasing Systems](#)

[Request for quote](#)

[Investor Relations](#)

[Amazon Business Card](#)

[Amazon Devices](#)

[Pay by Invoice](#)

[Purchasing Line](#)

[Amazon Business Blog](#)



Scan the QR code to download the new Amazon Business app



English

United States

[Alexa Actionable Analytics for the Web](#)

[Amazon Marketing Services Self-service Advertising Solutions](#)

[Amazon Payments Login and Pay with Amazon](#)

[Amazon Web Services Scalable Cloud Computing Services](#)

[Mechanical Turk On-demand Scalable Workforce](#)

[Buy for Others Kindle eBook Bulk Buying Solution](#)

[Conditions of Use](#) [Privacy Notice](#) [Your Ads Privacy Choices](#)

© 1996-2024, Amazon.com, Inc. or its affiliates

Publix

Cobblestone Plaza
125 Jenkins St.
St. Augustine, FL 32086
Store Manager: Meredith Pearson
904-608-9929



0099 COP 079 641

CHINET C/CRSL PLT	8.79	T
VANITY FAIR BEV NK	2.99	T
VANITY FAIR BEV NK	2.99	T
FRUIT SALAD MEDIUM	13.02	F
PBX PINWHEELS PLTR	39.99	F
GARDEN VEG PLTR S	21.99	F
You Saved	3.00	
Order Total	89.77	
Sales Tax	4.99	
Grand Total	94.76	
Credit	Payment	94.76
Change		0.00

Savings Summary

Special Price Savings	3.00

Your Savings at Publix	
3.00	

Receipt ID: 0099 COP 079 641

PRESTO!
Trace #: 078151
Reference #: 1097432774
Acct #: XXXXXXXXXXXX1284
Purchase American Express
Amount: \$94.76
Auth #: 853918

CREDIT CARD	PURCHASE
A00000025010801	AMERICAN EXPRESS
Entry Method:	Cardless
Mode:	Issuer

Your cashier was Linda B

12/16/2024 11:45 60099 R107 9641 00125

Join the Publix family!
Apply today at publix.jobs.
We're an equal opportunity employer.

Publix Super Markets, Inc.



Final Details for Order #112-9758538-4117842

Order Placed: December 15, 2024
Amazon.com order number: 112-9758538-4117842
Order Total: \$143.59

Business order information
Client purchasing for: Dream Finders Community purchasing for: Reverie at TrailMark

Shipped on December 16, 2024	
Items Ordered	Price
1 of: 40pcs Winter Napkins Decorations, Blue Winter Christmas Napkins, Christmas Tree Christmas Reindeer Napkins for Xmas Winter Holiday Party Christmas Birthday Party Supplies Sold by: Mbetray (seller profile) Condition: New	\$10.99
Shipping Address: Katharine Passantino 35 RUSTIC MILL DR SAINT AUGUSTINE, FL 32092-7940 United States	Item(s) Subtotal: \$10.99 Shipping & Handling: \$0.00 ----- Total before tax: \$10.99 Sales Tax: \$0.71 -----
Shipping Speed: FREE Prime Delivery	Total for This Shipment: \$11.70 -----

Shipped on December 16, 2024	
Items Ordered	Price
1 of: Rubtlamp 100Pcs Clear Plastic Plates, Heavy-Duty Party Plates, Clear Hammered Plastic Plates, Elegant Plastic Plates Inc Iude 50 Clear Dessert/Salad Plates, 50 Dinner Plates for Party Sold by: Pick Pick Us (seller profile) Condition: New	\$35.99
Shipping Address: Katharine Passantino 35 RUSTIC MILL DR SAINT AUGUSTINE, FL 32092-7940 United States	Item(s) Subtotal: \$35.99 Shipping & Handling: \$0.00 ----- Total before tax: \$35.99 Sales Tax: \$2.34 -----
Shipping Speed: FREE Prime Delivery	Total for This Shipment: \$38.33 -----

Shipped on December 16, 2024	
------------------------------	--

Items Ordered	Price
<p>1 of: <i>MOMO RUCCI Snowflake Balloons Arch Garland Kit,145Pc Winter Wonderland Decorations Blue White Silver Balloon for Christm</i> <i>as a Little Snowflake is on the Way Baby Shower Ice Snow Princess Birthday Party</i> Sold by: DivaDona (seller profile) Condition: New</p>	\$17.89
<hr/>	
<p>Shipping Address: Katharine Passantino 35 RUSTIC MILL DR SAINT AUGUSTINE, FL 32092-7940 United States</p>	Item(s) Subtotal: \$17.89 Shipping & Handling: \$0.00 ----- Total before tax: \$17.89 Sales Tax: \$1.16 -----
<p>Shipping Speed: FREE Prime Delivery</p>	Total for This Shipment: \$19.05 -----

Shipped on December 17, 2024

Items Ordered	Price
<p>1 of: <i>3D Hollow Christmas Winter Hanging Snowflakes Ornaments Decorations Glittery Large Snowflake Pendant Garlands for Winter</i> <i>Wonderland Party Home Decoration (Silver, Light Blue, Dark Blue,18 Pieces)</i> Sold by: Joinka (seller profile) Condition: New</p>	\$15.99
<hr/>	
<p>Shipping Address: Katharine Passantino 35 RUSTIC MILL DR SAINT AUGUSTINE, FL 32092-7940 United States</p>	Item(s) Subtotal: \$15.99 Shipping & Handling: \$0.00 ----- Total before tax: \$15.99 Sales Tax: \$1.04 -----
<p>Shipping Speed: FREE Prime Delivery</p>	Total for This Shipment: \$17.03 -----

Shipped on December 18, 2024

Items Ordered	Price
<p>2 of: <i>Max Fun 24 Pieces Christmas Glasses Frame and Headbands Set with 24 Cute Designs Exquisite Decoration Accessories for Ch</i> <i>ristmas Parties Holiday Favors and Photo Booth</i> Sold by: Woostasy (seller profile) Condition: New</p>	\$26.99
<hr/>	
<p>Shipping Address: Katharine Passantino 35 RUSTIC MILL DR SAINT AUGUSTINE, FL 32092-7940 United States</p>	Item(s) Subtotal: \$53.98 Shipping & Handling: \$0.00 ----- Total before tax: \$53.98 Sales Tax: \$3.50 -----
<p>Shipping Speed: FREE Prime Delivery</p>	Total for This Shipment: \$57.48 -----

Payment information

Payment Method:

American Express | Last digits: 1284

Item(s) Subtotal: \$134.84

Shipping & Handling: \$0.00

Billing address

Katharine Passantino
6557 THE MASTERS AVE
LAKEWOOD RANCH, FL 34202-2556
United States

Total before tax: \$134.84

Estimated Tax: \$8.75

Grand Total: \$143.59

Credit Card transactions

American Express ending in 1284: December 18, 2024: \$143.59

To view the status of your order, return to [Order Summary](#).

[Conditions of Use](#) | [Privacy Notice](#) © 1996-2020, Amazon.com, Inc.

Publix

Shoppes at Mirabella
84 Tuscan Way
Saint Augustine, FL 32092
Store Manager: Kevin Carline
904-940-2883



1239 CIF 077 201

CHINET C/CRSTL PLT	8.79 T
CHINET C/CRSTL PLT	8.79 T
VANITY FAIR BEV NR	2.99 T
VANITY FAIR BEV NR	2.99 T
CHINET C/CRSTL 902	8.79 T
CHOCOLATE HUMMUS M	21.99 T F
FRESH FRUIT/CHZ PLTR	44.99 T F
TASTE OF GREECE	37.99 T F

Order Total	137.32	
Sales Tax	8.93	
Grand Total	146.25	
Credit	Payment	146.25
Change	0.00	

Receipt ID: 1239 CIF 077 201

PRESID:

Trace #: 077142

Reference #: 1099576262

Acct #: XXXXXXXXXXXX1284

Purchase American Express

Amount: \$146.25

Auth #: 807620

CREDIT CARD

A00000025010801

Entry Method:

Mode:

PURCHASE
AMERICAN EXPRESS

Cardless

Issuer

Your cashier was Kathy

12/18/2024 16:29 S1239 R107-7201 1239

Join the Publix Team!
Apply today at apply.publix.com
We're an equal opportunity employer.

Publix Super Markets, Inc.



Final Details for Order #112-7269722-4822665

Order Placed: December 17, 2024
Amazon.com order number: 112-7269722-4822665
Order Total: \$243.49

Business order information
Client purchasing for: Dream Finders Community purchasing for: Reverie at TrailMark

Shipped on December 18, 2024	
Items Ordered	Price
1 of: <i>Plastic Balloon Bag w/Balloons Party Accessory (1 count)</i> Sold by: Amazon.com Condition: New	\$15.90
Shipping Address: Katharine Passantino 35 RUSTIC MILL DR SAINT AUGUSTINE, FL 32092-7940 United States	Item(s) Subtotal: \$15.90 Shipping & Handling: \$0.00 ----- Total before tax: \$15.90 Sales Tax: \$1.03 -----
Shipping Speed: FREE Prime Delivery	Total for This Shipment: \$16.93 -----

Shipped on December 18, 2024	
Items Ordered	Price
1 of: <i>FOCUSLINE 100 Pack Plastic Champagne Flutes, 4.5 Oz Gold Rim Glasses, Disposable Clear Toasting Glasses Recyclable Cups for Wedding Party</i> Sold by: MINH DING (seller profile) Business Price Condition: New	\$31.89
1 of: <i>Black Golden Balloons Photography Background Gold Champagne Bokeh Photo Backdrops for Graduation Prom Holiday Party Supp</i> <i>lies Father's Day Birthday Decoration Studio Props Banner 7X5ft</i> Sold by: QYYL (seller profile) Condition: New	\$9.60
1 of: <i>AULE Metallic Gold and Premium Latex Black White Balloons 60 Pack 12inches and Black Gold Confetti Balloons with Gold Ri</i> <i>bbons Set for Birthday Graduation Wedding Party Decorations</i> Sold by: COLORFUL ELVES (seller profile) Business Price Condition: New	\$9.29
Shipping Address:	Item(s) Subtotal: \$50.78

Katharine Passantino
35 RUSTIC MILL DR
SAINT AUGUSTINE, FL 32092-7940
United States

Shipping Speed:
FREE Prime Delivery

Shipping & Handling: \$0.00

Total before tax: \$50.78

Sales Tax: \$3.29

Total for This Shipment: \$54.07

Shipped on December 18, 2024

Items Ordered

Price

1 Of: *wellent 48 PCS LED Foam Glow Sticks, Bulk Glow Sticks, Glow in the Dark Party Supplies with 3 Modes Colorful Flashing, Neon Party Favors Supplies for Glow Party, Birthday, Wedding, Carnival, Concert* \$41.99

Sold by: Wellent Store ([seller profile](#))

Condition: New

1 Of: *OLUPP 325PCS Glow in the Dark Party Supplies, Glow Sticks Glasses Favors, 300 PCS Glow Sticks and 25 PCS LED Glasses, Neon Party Favors for Glow Party, Wedding, Concert, Raves, Birthday, New Year* \$39.99

Sold by: OLUPP ([seller profile](#))

Condition: New

Shipping Address:

Katharine Passantino
35 RUSTIC MILL DR
SAINT AUGUSTINE, FL 32092-7940
United States

Item(s) Subtotal: \$81.98

Shipping & Handling: \$0.00

Total before tax: \$81.98

Sales Tax: \$5.33

Shipping Speed:

FREE Prime Delivery

Total for This Shipment: \$87.31

Shipped on December 19, 2024

Items Ordered

Price

1 Of: *Newwiew 12 Pcs 72 Inch Satin Tablecloth Square Tablecloth Overlay Smooth Fabric Tablecloth Satin Table Cover for Party Wedding Banquet Table Decoration (Gold)* \$57.99

Sold by: Jananuy ([seller profile](#))

Condition: New

Shipping Address:

Katharine Passantino
35 RUSTIC MILL DR
SAINT AUGUSTINE, FL 32092-7940
United States

Item(s) Subtotal: \$57.99

Shipping & Handling: \$0.00

Total before tax: \$57.99

Sales Tax: \$3.77

Shipping Speed:

FREE Prime Delivery

Total for This Shipment: \$61.76

Shipped on December 20, 2024

Items Ordered	Price
1 Of: <i>Happy New Year Decorations 2025, New Years Eve Party Supplies with Black and Gold Garland Arch Kit New Year Balloon Boxe</i> <i>s 2025 Star Foil Balloons for Happy New Year Birthday Graduations Party Decòr</i> Sold by: Ouddy (seller profile) Condition: New	\$21.99
Shipping Address:	
Katharine Passantino 35 RUSTIC MILL DR SAINT AUGUSTINE, FL 32092-7940 United States	Item(s) Subtotal: \$21.99 Shipping & Handling: \$0.00 ----- Total before tax: \$21.99 Sales Tax: \$1.43 -----
Shipping Speed: FREE Prime Delivery	Total for This Shipment: \$23.42 -----

Payment information	
Payment Method: American Express Last digits: 1284	Item(s) Subtotal: \$228.64 Shipping & Handling: \$0.00 -----
Billing address Katharine Passantino 6557 THE MASTERS AVE LAKEWOOD RANCH, FL 34202-2556 United States	Total before tax: \$228.64 Estimated Tax: \$14.85 ----- Grand Total: \$243.49
Credit Card transactions	American Express ending in 1284: December 20, 2024: \$243.49

To view the status of your order, return to [Order Summary](#) .

Order Placed: December 20, 2024
 Amazon.com order number: 112-1242944-9034611
 Order Total: \$108.78

Business order information
Client purchasing for: Dream Finders Community purchasing for: Reverie at TrailMark

Shipped on December 21, 2024	
Items Ordered	Price
3 of: <i>Oojami 6 Oz Clear Plastic Champagne Glasses 24 Pack, Hard Disposable Plastic Champagne Flute Party Wedding Toasting Drink Champagne Flutes</i> Sold by: Oojami (seller profile) Business Price Condition: New	\$19.49
Shipping Address: Katharine Passantino 35 RUSTIC MILL DR SAINT AUGUSTINE, FL 32092-7940 United States	Item(s) Subtotal: \$58.47 Shipping & Handling: \$0.00 ----- Total before tax: \$58.47 Sales Tax: \$3.81 -----
Shipping Speed: Delivery in fewer trips to your address	Total for This Shipment: \$62.28 -----

Shipped on December 21, 2024	
Items Ordered	Price
1 of: <i>Oojami 6 Oz Clear Plastic Champagne Glasses 24 Pack, Hard Disposable Plastic Champagne Flute Party Wedding Toasting Drink Champagne Flutes</i> Sold by: Oojami (seller profile) Business Price Condition: New	\$19.49
1 of: <i>AULE Metallic Gold and Premium Latex Black White Balloons 60 Pack 12inches and Black Gold Confetti Balloons with Gold Ribbons Set for Birthday Graduation Wedding Party Decorations</i> Sold by: COLORFUL ELVES (seller profile) Business Price Condition: New	\$9.29
1 of: <i>Plastic Balloon Bag w/Balloons Party Accessory (1 count)</i> Sold by: Amazon.com Condition: New	\$14.88

Shipping Address:
Katharine Passantino
35 RUSTIC MILL DR
SAINT AUGUSTINE, FL 32092-7940
United States

Shipping Speed:
Delivery in fewer trips to your address

Item(s) Subtotal: \$43.66
Shipping & Handling: \$0.00

Total before tax: \$43.66
Sales Tax: \$2.84

Total for This Shipment: \$46.50

Payment information

Payment Method:
American Express I Last digits: 1284

Billing address
Katharine Passantino
6557 THE MASTERS AVE
LAKEWOOD RANCH, FL 34202-2556
United States

Item(s) Subtotal: \$102.13
Shipping & Handling: \$0.00

Total before tax: \$102.13
Estimated Tax: \$6.65

Grand Total: \$108.78

Credit Card transactions American Express ending in 1284: December 21, 2024: \$108.78

To view the status of your order, return to [Order Summary](#) .

[Conditions of Use](#) | [Privacy Notice](#) © 1996-2020, Amazon.com, Inc.



St Augustine - 904-810-2336
 1440 US Hwy 1 S
 Saint Augustine, Florida 32084-4211
 12/20/2024 07:03 PM



GROCERY
 071930002 OREG 1F \$2.19
 261060003 KRAFT 1F \$3.18
 2 @ \$1.59 ea
 076431319 FD DRINK BMB 1F \$30.00
 2 @ \$15.00 ea
 055001351 FD MUSHMLW 1F \$10.00
 2 @ \$5.00 ea
 055001440 FD MUSHMLW 1F \$10.00
 2 @ \$5.00 ea
 1795001256 FD COCOA 1F \$10.00
 HEALTH AND BEAUTY
 253070015 tp. & tp 1 \$2.58
 2 @ \$1.29 ea
 KITCHEN
 072000010 Chefman 1 \$59.98
 2 @ \$29.99 ea
 STATIONERY & OFFICE SUPPLIES
 053711307 AmercnDretnng 1 \$4.99
 051089528 ELF 1 \$5.00
 051021652 WONDERSHOP 1 \$10.00

SUBTOTAL \$147.92
 FL TAX 6.5000 on \$102.55 \$6.67
 TOTAL \$154.59
 *1284 AMEX CHARGE \$154.59
 AID: A00000025010801
 AMERICAN EXPRESS
 AUTH CODE: 867562

WHEN YOU RETURN ANY ITEM, YOUR
 RETURN CREDIT WILL NOT INCLUDE ANY
 PROMOTIONAL DISCOUNT OR COUPON
 APPLIED TO THE ORIGINAL ORDER.

REC#2-4355-1294-0073-0691-1

Help make your Target Run better.
 Take a 2 minute survey about today's trip

informtarget.com
 User ID: 7564 4870 6992
 Password: 691 089

CUENTENOS EN ESPAÑOL

Please take this survey within 7 days

You could win a \$1000 GiftCard!
Visit survey.walmart.com#77P4LY68/BV
For more details, see back of receipt



WM Supercenter
904-797-3309 Mer. SRINIVAS
2355 US HIGHWAY 1 S
ST AUGUSTINE FL 32086
ST# 00879 DP# 001381 TER 24 TR# 04206

8 ITEMS SOLD 18
TC# 6130 B481 4204 7046 0380 1



COTTON BALLS 048341003770	2.98 X
COTTON BALLS 048341003770	2.98 X
COTTON BALLS 048341003770	2.98 X
MS 3PK UTENS 016346902630	1.77 X
SLEEP MASK 769898881090	2.97 X
SLEEP MASK 769898881090	2.97 X
MS CHUNKY #01418241280	1.42 X
OVENMITTS #40525031930	8.88 X
16PK BALLS 022276700030	3.97 X
16PK BALLS 022276700030	3.97 X
OVENMITTS #40525031930	8.88 X
TT JAR MD 196587234620	11.98 X
TT JAR SM 196587234630	9.98 X
1Q PENNY CR 076440140160	7.22 X
DX 12OZ 4OCT 042000162660	8.12 X
GV SPRINKLES 078742348230 F	4.98 X
CHOC SPK TUB 078742199260 F	3.88 X
CHOCO SPRKLS 078742199270 F	2.12 X

SUBTOTAL 98.65
TAX1 \$ 5.00 X 6.87
TOTAL 104.42

AMEX TEND 104.42
CHANGE DUE 0.00

AMERICAN EXPRESS - 1284 1 0 APR8839316
104.42 TOTAL PURCHASE
REF # 435600289639
TRANS ID - 010183192782376
AID R00000025010801
TERMINL # 54800313
*No Signature Required
12/21/24 12:45:20



Low prices You Can Trust. Every Day
12/21/24 12:45:23



Expense Report

ER-00653

Total
\$35.00

ONVIE REVERIE TM 12.12.24

Submitted By
Mackenzie Straley
mstraley@onplace.life

Report To
Monaca Onstad
monstad@onplace.life

Submitted On
30 Dec 2024

Report Duration
12 Dec 2024 - 12 Dec 2024

EXPENSE SUMMARY

S.No	Expense Details	Category	Amount (USD)
1.	06 Dec 2024 Merchant : EIG*CONSTANTCONTACT.CO Non Reimbursable Payment Mode : Credit Card Paid Through : Mackenzie - Cap1 - 3139 Project : OnVie Invoice Client : Yes Purchase Summary : Monthly constant contact fee	Marketing (6140)	\$35.00

Submitted By

Approved By

Mackenzie Straley

Monaca Onstad (001)

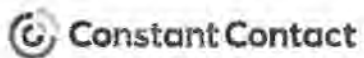

[Print](#)

Billing Activity

Reverie TrailMark Lifestyle

Attn: Mackenzie Straley

50 Rustic Mill Dr. Street

St. Augustine FL 32092

US

P.: 9415040852

Today's Date: 12/27/2024

User Name:

Billing Activity from 11/27/2024 to 12/27/2024

Date	Description	Charge Amount	Credit Amount
12-06-2024 03:33:40 AM	Payment - Credit Card (MasterCard) *****3139		\$35.00
12/06/2024	Invoice #1733474018	\$35.00	

Billing questions? [Contact Support](#)

Constant Contact - 1601 Trapelo Road - Waltham, MA 02451 US



Expense Report

ER-00606

Total

\$1,200.05

Reverie at TrailMark 01.07.2025

Submitted By
Cassie Passantino
kpassantino@onplace.life

Report To
Erin Steele
esteele@onplace.life

Submitted On
09 Jan 2025

Report Duration
07 Jan 2025 - 07 Jan 2025

EXPENSE SUMMARY

S.No	Expense Details	Category	Amount (USD)
1.	22 Dec 2024 Merchant : Party City Non Reimbursable Payment Mode : Credit Card Paid Through : Additional Business Expense Card on Business Platinum Customer : Dream Finders LLC [Non-Billable] Project : DreamFinders Invoice Client : Yes Event Name : Coastal Winter Wonderland Event Date : 21 Dec 2024 Purchase Summary : Supplies for Coastal Winter Wonderland	Event Expenses (6130)	\$31.68

2.	<p>22 Dec 2024 Merchant : Publix Non Reimbursable</p> <p>Payment Mode : Credit Card Paid Through : Additional Business Expense Card on Business Platinum Customer : Dream Finders LLC (Non-Billable) Project : DreamFinders Invoice Client : Yes Event Name : Coastal Winter Wonderland Event Date : 21 Dec 2024 Purchase Summary : Supplies for Coastal Winter Wonderland</p>	Event Expenses (6130)	\$165.92
3.	<p>23 Dec 2024 Merchant : Amazon Non Reimbursable</p> <p>Payment Mode : Credit Card Paid Through : Additional Business Expense Card on Business Platinum Customer : Dream Finders LLC (Non-Billable) Project : DreamFinders Invoice Client : Yes Event Name : Holiday Sweet Swap Event Date : 22 Dec 2024 Purchase Summary : To-go boxes for Holiday Sweet Swap</p>	Event Expenses (6130)	\$36.67
4.	<p>23 Dec 2024 Merchant : Publix Non Reimbursable</p> <p>Payment Mode : Credit Card Paid Through : Additional Business Expense Card on Business Platinum Customer : Dream Finders LLC (Non-Billable) Project : DreamFinders Invoice Client : Yes Event Name : Holiday Sweet Swap Event Date : 22 Dec 2024 Purchase Summary : Supplies for Holiday Sweet Swap</p>	Event Expenses (6130)	\$44.47
5.	<p>28 Dec 2024 Merchant : Party City Non Reimbursable</p> <p>Payment Mode : Credit Card Paid Through : Additional Business Expense Card on Business Platinum Customer : Dream Finders LLC (Non-Billable) Project : DreamFinders Invoice Client : Yes Event Name : A Toast to the New Year Event Date : 07 Jan 2025 Purchase Summary : Party favors for A Toast to the New Year</p>	Event Expenses (6130)	\$125.22

6.	<p>30 Dec 2024 Merchant : Walmart Non Reimbursable</p> <p>Payment Mode : Credit Card Paid Through : Additional Business Expense Card on Business Platinum Customer : Dream Finders LLC (Non-Billable) Project : DreamFinders Invoice Client : Yes Event Name : Plastic bins for organization Event Date : 07 Jan 2025 Purchase Summary : Plastic bins for organization</p>	Event Expenses (6130)	\$72.10
7.	<p>31 Dec 2024 Merchant : Publix Non Reimbursable</p> <p>Payment Mode : Credit Card Paid Through : Additional Business Expense Card on Business Platinum Customer : Dream Finders LLC (Non-Billable) Project : DreamFinders Invoice Client : Yes Event Name : A Toast to the New Year Event Date : 31 Dec 2024 Purchase Summary : Cups, napkins, utensils, drinks for A Toast to the New Year</p>	Event Expenses (6130)	\$190.21
8.	<p>31 Dec 2024 Merchant : Walgreens Non Reimbursable</p> <p>Payment Mode : Credit Card Paid Through : Additional Business Expense Card on Business Platinum Customer : Dream Finders LLC (Non-Billable) Project : DreamFinders Invoice Client : Yes Event Name : Duct Tape for Lifestyle Event Date : 01 Jan 2025 Purchase Summary : Duct Tape for Lifestyle</p>	Event Expenses (6130)	\$17.02
9.	<p>01 Jan 2025 Merchant : Hobby Lobby Non Reimbursable</p> <p>Payment Mode : Credit Card Paid Through : Additional Business Expense Card on Business Platinum Customer : Dream Finders LLC (Non-Billable) Project : DreamFinders Invoice Client : Yes Event Name : A Toast to the New Year Event Date : 31 Dec 2024 Purchase Summary : Decor for A Toast to the New Year</p>	Event Expenses (6130)	\$44.84

10.	01 Jan 2025 Merchant : Michaels Non Reimbursable Payment Mode : Credit Card Paid Through : Additional Business Expense Card on Business Platinum Customer : Dream Finders LLC (Non-Billable) Project : DreamFinders Invoice Client : Yes Event Name : A Toast to the New Year Event Date : 31 Dec 2024 Purchase Summary : Table decor for A Toast to the New Year	Event Expenses (6130)	\$55.35
11.	01 Jan 2025 Merchant : Party City Non Reimbursable Payment Mode : Credit Card Paid Through : Additional Business Expense Card on Business Platinum Customer : Dream Finders LLC (Non-Billable) Project : DreamFinders Invoice Client : Yes Event Name : A Toast to the New Year Event Date : 31 Dec 2024 Purchase Summary : Party decor for A Toast to the New Year	Event Expenses (6130)	\$54.50
12.	01 Jan 2025 Merchant : Publix Non Reimbursable Payment Mode : Credit Card Paid Through : Additional Business Expense Card on Business Platinum Customer : Dream Finders LLC (Non-Billable) Project : DreamFinders Invoice Client : Yes Event Name : A Toast to the New Year Event Date : 31 Dec 2024 Purchase Summary : Food items for A Toast to the New Year	Event Expenses (6130)	\$309.34
13.	02 Jan 2025 Merchant : Dollar Tree Non Reimbursable Payment Mode : Credit Card Paid Through : Additional Business Expense Card on Business Platinum Customer : Dream Finders LLC (Non-Billable) Project : DreamFinders Invoice Client : Yes Event Name : A Toast to the New Year Event Date : 31 Dec 2024 Purchase Summary : Vases for A Toast to the New Year	Event Expenses (6130)	\$11.98

14.	03 Jan 2025 Merchant : Amazon Non Reimbursable Payment Mode : Credit Card Paid Through : Additional Business Expense Card on Business Platinum Customer : Dream Finders LLC (Non-Billable) Project : DreamFinders Invoice Client : Yes Event Name : Coffee creamer for coffee station in The Retreat Event Date : 01 Jan 2025 Purchase Summary : Coffee creamer for coffee station in The Retreat	Event Expenses (6130)	\$27.98
-----	---	-----------------------	----------------

15.	04 Jan 2025 Merchant : Amazon Non Reimbursable Payment Mode : Credit Card Paid Through : Additional Business Expense Card on Business Platinum Customer : Dream Finders LLC (Non-Billable) Project : DreamFinders Invoice Client : Yes Event Name : USB for Lifestyle Photos in Lobby Event Date : 01 Jan 2025 Purchase Summary : USB for Lifestyle Photos in Lobby	Event Expenses (6130)	\$12.77
-----	--	-----------------------	----------------

Submitted By

Approved By

Cassle Passantino

Erin Steele

440 CAL DRIVE SUITE 101
SAINT AUGUSTINE, FL 32084
904-640-8151

01200164369 24CT NEON PD	\$8.00	T
24CT NEON PINK BALE		
ORIG PRICE (\$8.00 ea)		
PROMO DISCOUNT	\$0.80	-
048419-45692 81ET PXL GCU	\$6.00	T
81ET PXL BLU STRIP		
PROMO DISCOUNT	\$0.60	-
132937243428 100CT CRBN B	\$4.75	T
100CT CRBN BLU LN		
ORIG PRICE (\$4.75 ea)		
PROMO DISCOUNT	\$0.24	-
192937439715 11X18IN RTNG	\$7.00	T
11X18IN RTNG TARY GLD DOT		
ORIG PRICE (\$7.00 ea)		
PROMO DISCOUNT	\$0.70	-
192937439715 11X18IN RTNG	\$7.00	T
11X18IN RTNG TARY GLD DOT		
ORIG PRICE (\$7.00 ea)		
PROMO DISCOUNT	\$0.70	-

SUBTOTAL	\$29.75	
GEN MERCH TAX @ 6.500%	\$1.95	
TOTAL	\$31.68	
CR AMEX	\$31.68	
ITEMS - 10	YOU SAVED \$3.04	

XXXXXXXXXXXX1284 CHIP
RPPPE: 81730E
Application Label: AMERICAN EXPRESS
AC: 19852864088602
IWR: 0000008000
ATA: A00000025010801
TSI: FROO
ARC: 00

STORE 914 TRN 57 REG 4
12-21-2024 01:06:04 PM

1E2 116K 004 0294



1E2116K0040294

All returns & exchanges require
an original receipt dated within
30 days of purchase or email to
look up receipt & must be
in original packaging with all
components in unused condition
or have manufacturer defect.
Seasonal items may be returned
up to 7 days prior to holidays.

Happy Holidays

Publix

Shoppers at Publix
84 Tucker Way
Saint Augustine, FL 32092
Store Manager: Kevin Carline
904-940-2889

RY TOPPING CREAM	6.49	F	
RY TOPPING X CREAM	6.49	F	
Promotion	-6.49	F	
RY TOPPING CREAM	6.49	F	
RY TOPPING X CREAM	6.49	F	
Promotion	-6.49	F	
SWISS MISS COCOA			
1 # 2 FOR	8.00	4.00	F
SWISS MISS COCOA			
1 # 2 FOR	8.00	4.00	F
SWISS MISS COCOA			
1 # 2 FOR	8.00	4.00	F
SWISS MISS COCOA			
1 # 2 FOR	8.00	4.00	F
PUBLIX SFG 24-80Z		4.19	F
PUBLIX SFG 24-80Z		4.19	F
NAB FAN SIZE WEO			
1 # 2 FOR	8.00	4.00	F
You Saved	1.84		
DEVILED EGG PLTR M		29.99	T F
FRSH FRZ/CHZ PLTR		29.99	T F
You Saved	5.00		
BREAD BOMB PLATTER		24.99	T F
CHOCOLATE HUMMUS M		21.99	T F

Order Total	158.32	
Sales Tax	7.60	
Grand Total	165.92	
Credit	Payment	165.92
Change	0.00	

Savings Summary
Special Price Savings 19.82

* Your Savings at Publix *
* 19.82 *

Receipt ID: 1239 CLP 754 552

PRESTOT
Trace #: 759013
Reference #: 1102058620
Acct #: 0000000000001204
Purchase American Express
Amount: \$165.92
Auth #: 865906

CREDIT CARD	PUBMISC
000000020010801	AMERICAN EXPRESS
Entry Method:	Directless
Mode:	Issuer

Your cashier was Self-Checkout Lane 1
12/21/2024 17:00 51205 R175 4992 10775

Join the Publix Family!
Apply today at apply.publix.com.
We're an equal opportunity employer.

Publix Super Markets, Inc.





Final Details for Order #112-4726160-9949865

Order Placed: December 18, 2024
Amazon.com order number: 112-4726180-9949865
Order Total: \$36.67

Business order information
Client purchasing for: Dream Finders Community purchasing for: Reverie at TrailMark

Shipped on December 22, 2024	
Items Ordered	Price
2 of: MOORAY 24 Pack Christmas Bakery Treat Cookie Boxes with Window, Bakery XMAS Treat Boxes, Candy and Cookie Boxes for Gift Giving, Christmas Kraft Gift Boxes with Ribbons and DIY Gift Tags Sold by: Mooray (seller profile) Business Price Condition: New	\$17.39
Shipping Address: Katharine Passantino 35 RUSTIC MILL DR SAINT AUGUSTINE, FL 32092-7940 United States	Item(s) Subtotal: \$34.78 Shipping & Handling: \$0.00 Promotion Applied: -\$0.35 ----- Total before tax: \$34.43 Sales Tax: \$2.24 -----
Shipping Speed: FREE Prime Delivery	Total for This Shipment: \$36.67 -----

Payment information	
Payment Method: American Express Last digits: 1284	Item(s) Subtotal: \$34.78 Shipping & Handling: \$0.00 Promotion applied: -\$0.35 ----- Total before tax: \$34.43 Estimated Tax: \$2.24 -----
Billing address Katharine Passantino 6557 THE MASTERS AVE LAKEWOOD RANCH, FL 34202-2556 United States	Grand Total: \$36.67
Credit Card transactions	American Express ending in 1284: December 22, 2024: \$36.67

To view the status of your order, return to [Order Summary](#).

Publix.

Cobblestone Plaza
125 Jenkins St.
St Augustine, FL 32086
Store Manager: Meredith Pearson
904-808-9929

CHINET C/CRSTL PLT	8.79	T
CHINET C/CRSTL PLT	8.79	T
ZILOC SLDR STRGBG	6.79	T
ZILOC SLDR STRGBG	6.79	T
24CT SUGAR COOKIES	5.29	F
15CT RASPB BITES	5.99	F

Order Total	42.44	
Sales Tax	2.03	
Grand Total	44.47	
Credit	Payment	44.47
Change	0.00	

Receipt ID: 0099 CMP 731 435

PREST01
Trace #: 731376
Reference #: 1103218442
Acct #: XXXXXXXXXXXX1284
Purchase American Express
Amount: \$44.47
Auth #: 823568

CREDIT CARD	PURCHASE
A00000025010801	AMERICAN EXPRESS
Entry Method:	Cntctless
Mode:	Issuer

Your cashier was Self-Checkout Lane 1
12/22/2024 9:38 50099 R173 1435 C0773

Join the Publix family!
Apply today at apply.publix.jobs.
We're an equal opportunity employer.

Publix Super Markets, Inc.



PartyCity

NOBODY HAS MORE PARTY FOR LESS

440 CBL DRIVE, SUITE 101
SAINT AUGUSTINE, FL 32086
904-690-8151

192937277119 BSG PRY KIT	\$31.99	T
BSG PRY KIT/25 NY		
ORIG PRICE (\$31.99 ea)		
PROMO DISCOUNT	\$6.40	-
192937277126 BSG PRY KIT	\$114.99	T
BSG PRY KIT/100 NY		
ORIG PRICE (\$114.99 ea)		
PROMO DISCOUNT	\$23.00	-

SUBTOTAL	\$117.58	
GEN MERCH TAX @ 6.500%	\$7.64	
TOTAL	\$125.22	
CR AMEX	\$125.22	
ITEMS = 2	YOU SAVED \$29.40	

XXXXXXXXXXXX1284 CHIP
APPR 835705
Application Label AMERICAN EXPRESS
ac: F7510EEF6CA70548
TVR 000008000
AID 800000025010801
TSI F800
ARC 00

STORE 914 TRN 97 REG 4
12-27-2024 07:01:23 PM

1E2 1172 004 041A



1E21172004041A

ALL SALES ARE FINAL

Happy Holidays

You could win a \$1000 GiftCard!
Visit survey.walmart.com/#7TP5K368FGB
For more details, see back of receipt.

Walmart 

WM Supercenter
904-797-3309 Mgr. SRINIVAS
2355 US HIGHWAY 1 S
ST AUGUSTINE FL 32086
ST# 00579 OP# 009028 TE# 28 TR# 02391

ITEMS SOLD 4
TC# 8039 6914 4669 2738 5760



HFT720T	025947716380	15.83 X
HF1130T BAJA	025947716420	19.97 X
HF1130T BAJA	025947716420	19.97 X
BBL CUSHION	075353128260	11.93 X

	SUBTOTAL	67.70
TAX1	6.5000 %	4.40
	TOTAL	72.10
	AMEX TEND	72.10
	CHANGE DUE	0.00

AMERICAN EXPRESS- 1284 I 0 APPR#862728
72.10 TOTAL PURCHASE
REF # 436500746262
TRANS ID - 010332884785325
AID A000000025010801
TERMINAL # 21155409

*No Signature Required
12/30/24 09:13:07



Get free delivery
from this store
with Walmart+

Scan for 30-day free trial

Low prices You Can Trust. Every Day.
12/30/24 09:13:22

Walgreens

#1165 5445 STATE ROAD 16
SAINT AUGUSTINE, FL 32052
904-940-5555

202 9061 0021 12/30/2024 4:20 PM

DUCK SZ STRIP PKG TAPE 1.88"X1980"
0753507958 A 6.99
RETURN VALUE 6.99
SCOTCH PACKAGING TAPE 1.88"X1965"
05113185365 A 8.99
RETURN VALUE 8.99

SUBTOTAL 15.98
SALES TAX A=6.5% 1.04

TOTAL 17.02
AMEX ACCT 1284 17.02
AUTH CODE 605486
CHANGE .00

THANK YOU FOR SHOPPING AT WALGREENS

YOU COULD HAVE EARNED AN ADDITIONAL
WALGREENS CASH REWARDS BY USING YOUR
MYWALGREENS MEMBERSHIP TODAY.
RESTRICTIONS APPLY. FOR TERMS AND
CONDITIONS, VISIT MYWALGREENS.COM.

NOT A MEMBER? JOIN NOW AT ANY REGISTER
OR GO TO MYWALGREENS.COM. ENROLLING IS
QUICK, EASY AND FREE! REDEEM WALGREENS
CASH REWARDS OFF FUTURE PURCHASES.

RFN# 1116-5219-0614-2412-3000



myW

HUNDREDS OF PHARMACY PLANS STILL COVER
COVID-19 OTC TEST KITS. ASK THE PHARMACY
IF YOUR PLAN COVERS TODAY!

How are we doing?
Enter our monthly sweepstakes for
\$3,000 cash

Visit
WWW.WALGREENSLISTENS.COM
or scan this code with your mobile device



or call toll free

1-855-855-5905
within 72 hours to take a short
survey about this Walgreens visit

SURVEY#
1116-5219-061

PASSWORD
4241-2300-326

For contest rules, see store or
WWW.WALGREENSLISTENS.COM

HOBBY LOBBY

Super Savings, Super Selection!

200 State Road 312

St. Augustine, FL 32085
Hobby Lobby Store #226 (904) 810-1031

0226 R-4 1-2400 JELLYMAR M SALE
103100000
Promo 40% Off (1/29-1/30)
2 @ 2.09 ea
106500000
4 @ 5.99 ea Floral 23.96
105000000
4 @ 3.49 ea Crafts 13.96

SUBTOTAL 42.10
TAX TOTAL 2.74
TOTAL 44.84

AMEX
ACCOUNT #: *****1264
AUTH# 88806
ACCT: AMEX
CARD # AMERICAN EXPRESS INGESTED
REF # *****1264
122912311042 AUTH # EXP ****
ATD: A00000029010801 RESP 00
1ST EB00 ARC: CUR:1610
TRN: 000000000
APP: AMERICAN EXPRESS
IAC: 06650103402002

NO STORES W/
CHANGE DUE 0.00
Number of Items Purchased, 10
Total savings: 2.80

Thank You. Please come again.
Become a fan on Facebook.
Sign up today for our Hobby Lobby App
Visit our website at www.hobbylobby.com



12/31/24 12:25 PM

RETURN POLICY

Hobby Lobby values customer satisfaction,
with or without the receipt

WITH ORIGINAL SALES RECEIPT
Within 90 days of purchase, we will gladly exchange the
merchandise, give a store credit, or issue a refund
without days of payment. A
30-day

Michaels

MICHAELS STORE #3717 (904) 879-9664
310 CBL Dr
St. Augustine, FL 32086

8 9841 9165 2249 8151 1111 9163 1543 8733



100 SALE 7874 3717 052

12/31/24 11:52

ITEM INFORMATION

Order NO 8981817557587210

6ft Silver Disco Ball ... 03195159727147 47 98 C
Reg 29.99 4 @ 12.00

183592-Christmas ... 71.98-

REUSABLE TOTE B... 00191518374877 3.99
Reg 3.99 1 @ 3.99

YOU SAVED 71.98

PURCHASE SUMMARY

SUBTOTAL 51.97
SALES TAX 6.50% 3.38
TOTAL 55.35

ACCOUNT NUMBER *** 1284
American Express 55.35

APPROVAL: 824143 CHIP ONLINE
Application label: AMERICAN EXPRESS

AID: A000000025010801
TVR: 0000008000
TSI: EB00

This receipt expires at 60 days on 03/01/25

Click. Buy. Create. Shop michaels.com today!
Get Sayings & Inspiration! Text* SIGNUP to 273283

To Sign Up for Email & Text Messages.

*Msg & Data Rates May Apply

You will receive 1 autodialed message
with a link to join Michaels alerts.

Now Hiring! Apply at michaels.com/jobs

THANK YOU FOR SHOPPING AT MICHAELS

Effective 11/27/2022 Clearance sales are considered
final, sold AS IS and are not
returnable for a refund or exchange.

Dear Valued Customer:
Michaels return and coupon policies are available
at michaels.com and in store at registers.

12/31/24 11:52

Publix

Stores at Marabell
84 Tucuman Way
Saint Augustine, FL 32032
Store Manager: Kevin Carino
904-940-2889



1239 CNP 098 211

TCE 7 LB		
5 @ 2.99		14.95 T F
PUBLIX SPRG 24-BOZ		
4 @ 4.19		16.76 F
SP POPCORN 100 L		59.99 T
CHK TEN BOX L HOT		75.99 T
BREAD BOWL PLATTER		24.94 T F
GARDEN VEG PLTR-I		37.99 T F
EOD-FOIL ROASTER		5.99 T
EOD-FOIL ROASTER		5.99 T
Promotion		-5.99 T
SPARKL APL CIDER J		
1 @ 2 FOR 8.00		4.00 T F
You Saved	0.49	
SPARKL FLY JUICE		
1 @ 2 FOR 8.00		4.00 T F
You Saved	0.49	
SPARKL FLY JUICE		
1 @ 2 FOR 8.00		4.00 T F
You Saved	0.49	
WELCH RED GRAPE JU		
1 @ 2 FOR 8.00		4.00 T F
You Saved	0.49	
WELCH RED GRAPE JU		
1 @ 2 FOR 8.00		4.00 T F
You Saved	0.49	
MART SPARKL CIDER		5.75 T F
SBR BUF WING SAUCE		3.99 F
SPARKL APL CIDER J		
1 @ 2 FOR 8.00		4.00 T F
You Saved	0.49	
WELCH ROSE GRAP JU		
1 @ 2 FOR 8.00		4.00 T F
You Saved	0.49	
SMT BABY RAY'S BBQ		4.99 F
HUNT'S KETCHUP		2.99 F
WELCH ROSE GRAP JU		
1 @ 2 FOR 8.00		4.00 T F
You Saved	0.49	
MART SPARKL CIDER		5.79 T F

Order total	292.21	
Sales Tax	17.13	
Grand Total	309.34	
Credit	Payment	309.34
Change	0.00	

Savings Summary

Special Price Savings	9.91

* Your Savings at Publix	*
* 9.91	*

Receipt ID: 1239 CNP 098 211

PRESTO!

 **DOLLAR TREE**

(904) 201-2048

Store# 199
 1938 US Highway 1 South
 St Augustine Fl 32085-4233

DESCRIPTION	QTY	PRICE	TOTAL
CYLINDER WASE 6IN	1	1.25	1.25
CYLINDER WASE 6IN	1	1.25	1.25
CYLINDER WASE 6IN	1	1.25	1.25
CYLINDER WASE 6IN	1	1.25	1.25
CYLINDER WASE 6IN	1	1.25	1.25
CYLINDER WASE 6IN	1	1.25	1.25
CYLINDER WASE 6IN	1	1.25	1.25
CYLINDER WASE 6IN	1	1.25	1.25
CYLINDER WASE 6IN	1	1.25	1.25

Sub Total \$11.25
 SALES TAX \$0.73
 Total \$11.98
 AMERICAN EXPRESS \$11.98
 *****1284 Approved
 Purchase Chip
 Auth/Trace Number: 837143/010437
 Chip Card AID: A00000025010801
 Mode: Issuer

NOW SHOP ON-LINE AT DOLLARTREE.COM

6925 00199 01 041 21690261 12/31/24 11:24
 Sales Associate:Virginia





Final Details for Order #112-1258918-1123462

Order Placed: January 2, 2025
Amazon.com order number: 112-1258918-1123462
Order Total: \$27.98

Business order information
Client purchasing for: Dream Finders Community purchasing for: Reverie at TrailMark

Shipped on January 3, 2025	
Items Ordered	Price
1 Of: Nestle Coffee mate Coffee Creamer, French Vanilla, Liquid Creamer Singles, Non Dairy, No Refrigeration, 0.375 fl oz Tubs (Pack of 360) Sold by: Amazon (seller profile) Business Price Condition: New	\$27.98
Shipping Address: Katharine Passantino 35 RUSTIC MILL DR SAINT AUGUSTINE, FL 32092-7940 United States	Item(s) Subtotal: \$27.98 Shipping & Handling: \$0.00 ----- Total before tax: \$27.98 Sales Tax: \$0.00 -----
Shipping Speed: FREE Prime Delivery	Total for This Shipment: \$27.98 -----

Payment information	
Payment Method: American Express Last digits: 1284	Item(s) Subtotal: \$27.98 Shipping & Handling: \$0.00 -----
Billing address Katharine Passantino 6557 THE MASTERS AVE LAKEWOOD RANCH, FL 34202-2556 United States	Total before tax: \$27.98 Estimated Tax: \$0.00 ----- Grand Total: \$27.98
Credit Card transactions	American Express ending in 1284: January 3, 2025: \$27.98

To view the status of your order, return to [Order Summary](#)



Final Details for Order #112-5782575-5689812

Order Placed: January 3, 2025
Amazon.com order number: 112-5782575-5689812
Order Total: \$12.77

Business order information
Client purchasing for: Dream Finders Community purchasing for: Reverie at TrailMark

Shipped on January 4, 2025	
Items Ordered	Price
1 of: SanDisk 128GB Ultra Flair USB 3.0 Flash Drive - SDCZ73-128G-G46, black Sold by: Amazon.com Condition: New	\$11.99
Shipping Address: Katharine Passantino 35 RUSTIC MILL DR SAINT AUGUSTINE, FL 32092-7940 United States	Item(s) Subtotal: \$11.99 Shipping & Handling: \$0.00 ----- Total before tax: \$11.99 Sales Tax: \$0.78 -----
Shipping Speed: FREE Prime Delivery	Total for This Shipment: \$12.77 -----

Payment information	
Payment Method: American Express Last digits: 1284	Item(s) Subtotal: \$11.99 Shipping & Handling: \$0.00 -----
Billing address Katharine Passantino 6557 THE MASTERS AVE LAKEWOOD RANCH, FL 34202-2556 United States	Total before tax: \$11.99 Estimated Tax: \$0.78 ----- Grand Total: \$12.77
Credit Card transactions	American Express ending in 1284: January 4, 2025: \$12.77

To view the status of your order, return to [Order Summary](#) .

Reverie at Trailmark Homeowners Association

c/o FirstService Residential
 1601 SW 80th Terrace
 Plantation, FL 33324

2095CCR-1
 1/21/2025

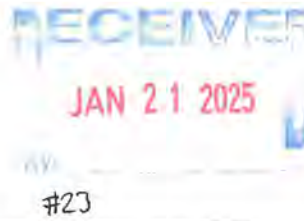

Bill To:
 Six Mile Creek Community Development District
 475 West Town Place, Suite 114
 St. Augustine, FL 32092

	Description	GL Code	Store/vendor	Amount	
10/24	Annual membership fee	002-340-53800-54000	Amazon	\$179.00	✓
9/24	Clear & Mild Foam Handwash, Push-Style Dispensers	002-340-53800-46900	Amazon	\$256.32	
10/24	Printer toner cartridges for lifestyle events, calendars	002-340-53800-51000	Amazon	\$296.99	✓
11/24	Roku remotes for Tavern TVs	002-340-53800-51000	Amazon	\$39.96	
↓	Roku remotes for Fintess Center TVs	002-340-53800-51000	Amazon	\$39.76	
			Subtotal	\$812.03	
			Tax	\$0.00	
			Grand Total:	\$812.03	

Terms: Net 30 Days

THANK YOU FOR YOUR BUSINESS!

Details for Order # D01-3059831-1459404

[Print this page for your records.](#)

Placed By: Six Mile Creek CDD - Reverie

Amazon.com order number: D01-3059831-1459404

Order Total: \$179.00

Digital Order: October 14, 2024	
Items Ordered	Price
Business Prime Annual Membership Fee - Essentials	\$179.00
Quantity: 1	
Sold By: Amazon.com Services LLC	
	Item(s) Subtotal: \$179.00

	Total Before Tax: \$179.00
	Tax Collected: \$0.00

	Total for this Order: \$179.00

Payment Information	
Payment method	Item(s) Subtotal: \$179.00
VISA Visa ending in 2603	Total Before Tax: \$179.00
Billing address	Tax Collected: \$0.00
Matthew Reid 475 West Town Place, Ste 114 SAINT AUGUSTINE, FL 32092 United States 9549262934	Grand Total: \$179.00

[Return to the Order Summary.](#)

Please note: This is not a VAT invoice.

Have an idea to help us improve? [Send feedback](#) >

Get to Know Us

- Careers
- Blog
- About Amazon
- Sustainability
- Press Center
- Investor Relations
- Amazon Devices

Let Us Help You

- Customer Service
- Shipping Rates & Policies
- Business FAQ
- Contact Us

Work with Amazon

- Sell on Amazon Business
- Fulfillment By Amazon
- Advertise on Amazon
- Amazon Global Selling

Business Solutions

- Amazon Business app
- Amazon Business Solutions
- Manage Suppliers
- Purchasing Systems
- Amazon Business Card
- Pay by Invoice
- Purchasing Line
- Amazon Business Blog

Business Settings

- Add people
- Simplify Your Reporting
- Billing & shipping
- Manage your Budgets (Blanket PO)
- Buying Policies & Approvals
- Tax Exemption & Licenses
- System integrations

Buy For Your Business

- Buy wholesale
- Today's Deals
- Buy Again
- PPE for Work
- Request for quote



Scan the QR code to download the new Amazon Business app



English

United States

Alexa
Actionable
Analytics
for the
Web

Amazon
Marketing
Services
Self-
service
Advertising
Solutions

Amazon
Payments
Login
and Pay
with
Amazon

Amazon
Web
Services
Scalable
Cloud
Computing
Services

Mechanical
Turk
On-
demand
Scalable
Workforce

Buy for
Others
Kindle
eBook
Bulk
Buying
Solution

[Conditions of Use](#) [Privacy Notice](#) [Your Ads Privacy Choices](#)

© 1996-2025, Amazon.com, Inc. or its affiliates



Final Details for Order #111-2646481-2064226

Order Placed: September 14, 2024

PO number : OSPU

Amazon.com order number: 111-2646481-2064226

Order Total: \$256.32

Shipped on September 15, 2024

Items Ordered	Price
4 of: GOJO Clear & Mild Foam Handwash, EcoLogo Certified, 700 mL Hand Soap Refill ADX-7 Push-Style Dispenser (Pack of 4) - 8711-04 Sold by: Amazon.com Condition: New	\$42.72

Shipping Address: Matthew Reid 35 RUSTIC MILL DR ST AUGUSTINE, FL 32092-7940 United States	Item(s) Subtotal: \$170.88 Shipping & Handling: \$0.00 ----- Total before tax: \$170.88 Sales Tax: \$0.00 -----
Shipping Speed: FREE Prime Delivery	Total for This Shipment: \$170.88 -----

Shipped on September 16, 2024

Items Ordered	Price
1 of: GOJO Clear & Mild Foam Handwash, EcoLogo Certified, 700 mL Hand Soap Refill ADX-7 Push-Style Dispenser (Pack of 4) - 8711-04 Sold by: Amazon.com Condition: New	\$42.72

Shipping Address: Matthew Reid 35 RUSTIC MILL DR ST AUGUSTINE, FL 32092-7940 United States	Item(s) Subtotal: \$42.72 Shipping & Handling: \$0.00 ----- Total before tax: \$42.72 Sales Tax: \$0.00 -----
Shipping Speed: FREE Prime Delivery	Total for This Shipment: \$42.72 -----

Shipped on September 16, 2024

Items Ordered	Price
1 of: GOJO Clear & Mild Foam Handwash, EcoLogo Certified, 700 mL Hand Soap Refill ADX-7 Push-Style Dispenser (Pack of 4) - 8711-04 Sold by: Amazon.com Condition: New	\$42.72

Shipping Address: Matthew Reid 35 RUSTIC MILL DR ST AUGUSTINE, FL 32092-7940 United States	Item(s) Subtotal: \$42.72 Shipping & Handling: \$0.00 ----- Total before tax: \$42.72 Sales Tax: \$0.00 -----
Shipping Speed: FREE Prime Delivery	Total for This Shipment: \$42.72 -----

Payment information	
Payment Method: Visa Last digits: 2603	Item(s) Subtotal: \$256.32 Shipping & Handling: \$0.00 -----
Billing address Matthew Reid 475 West Town Place, Ste 114 SAINT AUGUSTINE, FL 32092 United States	Total before tax: \$256.32 Estimated Tax: \$0.00 ----- Grand Total: \$256.32
Credit Card transactions	Visa ending in 2603: September 16, 2024: \$256.32

To view the status of your order, return to [Order Summary](#).

[Conditions of Use](#) | [Privacy Notice](#) © 1996-2020, Amazon.com, Inc.



Final Details for Order #112-4161848-9209802

Order Placed: October 22, 2024
PO number : 0SPU
Amazon.com order number: 112-4161848-9209802
Order Total: \$296.99

Shipped on October 23, 2024	
Items Ordered 1 of: 414A 414X High Yield Toner Cartridges 4 Pack/ Replacement for 414A W2020A W2020X Work for Color Pro MFP M479fdn M479fdw M454dw M454dn M454 M479 Printer Ink/ Black Cyan Yellow Magenta (with Chip) Sold by: Getonereal (seller profile) Condition: New	Price \$296.99
Shipping Address: Matthew Reid 35 RUSTIC MILL DR ST AUGUSTINE, FL 32092-7940 United States	Item(s) Subtotal: \$296.99 Shipping & Handling: \$0.00 ----- Total before tax: \$296.99 Sales Tax: \$0.00 ----- Total for This Shipment: \$296.99 -----
Shipping Speed: Standard Shipping	

Payment information	
Payment Method: Visa Last digits: 2603	Item(s) Subtotal: \$296.99 Shipping & Handling: \$0.00 -----
Billing address Matthew Reid 475 West Town Place, Ste 114 SAINT AUGUSTINE, FL 32092 United States	Total before tax: \$296.99 Estimated Tax: \$0.00 ----- Grand Total: \$296.99
Credit Card transactions	Visa ending in 2603: October 23, 2024: \$296.99

To view the status of your order, return to [Order Summary](#) .



Final Details for Order #113-2376700-9053869

Order Placed: November 4, 2024
PO number : OSPU
Amazon.com order number: 113-2376700-9053869
Order Total: \$39.96

Shipped on November 4, 2024	
Items Ordered	Price
4 Of: Roku Remote (Official Manufacturer Product) TV Remote Control with TV Controls, Simple Setup, & Pre-Set App Shortcuts - Replacement Remote Compatible with Roku TV Models ONLY (Not Roku Players)	\$9.99
Sold by: Amazon.com Condition: New	
Shipping Address: Matthew Reid 35 RUSTIC MILL DR ST AUGUSTINE, FL 32092-7940 United States	Item(s) Subtotal: \$39.96 Shipping & Handling: \$0.00 ----- Total before tax: \$39.96 Sales Tax: \$0.00 -----
Shipping Speed: FREE Prime Delivery	Total for This Shipment: \$39.96 -----

Payment information	
Payment Method: Visa Last digits: 2603	Item(s) Subtotal: \$39.96 Shipping & Handling: \$0.00 -----
Billing address Matthew Reid 475 West Town Place, Ste 114 SAINT AUGUSTINE, FL 32092 United States	Total before tax: \$39.96 Estimated Tax: \$0.00 ----- Grand Total: \$39.96
Credit Card transactions	Visa ending in 2603: November 4, 2024: \$39.96

To view the status of your order, return to [Order Summary](#).



Final Details for Order #113-4063671-9190618

Order Placed: November 6, 2024
PO number : OSPU
Amazon.com order number: 113-4063671-9190618
Order Total: \$39.76

Shipped on November 6, 2024	
Items Ordered	Price
2 of: Roku Voice Remote / TV Remote Control with Voice Control, TV Controls, Simple Setup, & Pre-Set App Shortcuts - Replacement Remote Compatible with Roku TV, Roku Players, & Roku Audio Sold by: Amazon.com Condition: New	\$19.88
Shipping Address: Matthew Reid 35 RUSTIC MILL DR ST AUGUSTINE, FL 32092-7940 United States	Item(s) Subtotal: \$39.76 Shipping & Handling: \$0.00 ----- Total before tax: \$39.76 Sales Tax: \$0.00 -----
Shipping Speed: FREE Prime Delivery	Total for This Shipment: \$39.76 -----

Payment information	
Payment Method: Visa Last digits: 2603	Item(s) Subtotal: \$39.76 Shipping & Handling: \$0.00 -----
Billing address Matthew Reid 475 West Town Place, Ste 114 SAINT AUGUSTINE, FL 32092 United States	Total before tax: \$39.76 Estimated Tax: \$0.00 ----- Grand Total: \$39.76
Credit Card transactions	Visa ending in 2603: November 6, 2024: \$39.76

To view the status of your order, return to [Order Summary](#) .

TURNER WGV LLC
 6205 STATE ROAD 16
 ST. AUGUSTINE FL 32094

PHONE: (904) 907-2424

CUST NO: 4055 JOB NO: 000 PURCHASE ORDER: REFERENCE: TERMS: NET 20TH CLERK: CSS DATE / TIME: 1/14/25 2:43

DUE DATE: 2/20/25 TERMINAL: 402

SOLD TO:
 SIX MILE CREEK COMMUNITY
 6200 Lee Vista Blvd, St 300
 Orlando FL 32822
 877-221-6919

SHIP TO:

TAX: WGV DEFAULT TAX CODE ST4

INVOICE: 9672 /4

SKU	MFG PART #	DESCRIPTION	SUGG	UNITS	PRICE /PER	EXTENSION
42904	241571	DUCT TAPE 60YDS GRAY ACE	8.99	1	8.99 EA	8.99 N
53330	ACE53330	ACE FINISH 3D 1.25 1#	6.99	1	6.99 EA	6.99 N
		#30 002-340-53800-47500 Received: 1/15/25 Approved: Matthew Reid CAM				

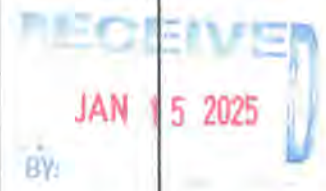

(BRIAN HYMAN)
 ** AMOUNT CHARGED TO STORE ACCOUNT ** 15.98

TAXABLE 0.00
 NON-TAXABLE 15.98
 SUBTOTAL 15.98

TAX AMOUNT 0.00
TOTAL 15.98

TOT WT: 2.70

X 
 Received By



Air-Max Heating & Cooling, Inc.
 Lic# CAC048100
 449 College Dr.
 Middleburg, Florida 32068-6508
 (904) 276-4340

Invoice 33335640
 Invoice Date 1/24/2025
 Completed Date 1/24/2025
 Customer PO
 Due Date 1/24/2025

#5)
 002-340-53800-47500
 Received: 1/27/25
 Approved: Matthew Reid CAM



Billing Address
 Six Mile Creek CDD
 6200 Lee Vista Boulevard #Ste. 300
 Orlando, FL 32801 USA

Job Address
 Reverie Amenity Center
 35 Rustic Mill Drive
 St. Augustine, FL 32092 USA

Description of Work

Customer advises us that Aerobics & Fitness room does not have any heat. Found condenser locked out on low pressure - reset and cycled power. After resetting checked over refrigerant pressures, amps, capacitor and motors, and units running operations. Ran unit through a few cycles -never showed any issues after resetting. Everything looks good and is running good at this time. Showed maintenance person where filter goes in.

***A 3% credit card fee has been added to this invoice. If paying by check, please make out for \$255.

Task #	Description	Quantity	Your Price	Your Total
SCF - AH WK LD FED HOL	Service Call Fee - After-Hours, Weekend Rate, Long Distance (between the hours of 8AM - 5PM) or Federal Holiday. Long Distance Cities Include but are not limited to: Amelia Island, Atlantic Beach, Baldwin, Fernandina Beach, Hawthorne, Keystone Heights, Macclenny, . Melrose, Neptune Beach, Palatka, Ponte Vedra, Ponte Vedra Beach, St. Augustine, Starke and Yulee. Effective January 01, 2025 - a convenience fee of 3% will be applied to all credit card transactions. Customers may avoid this extra fee by paying with cash or check.	1.50	\$170.00	\$255.00

#	Description	Total
Credit Card Convenience Fee	3% Credit Card Convenience Fee will be applied to all credit card transactions. Customers may avoid this extra fee by paying with cash or check.	\$7.65

Sub-Total	\$262.65
Tax	\$0.00
Total Due	\$262.65
Balance Due	\$262.65

Thank you for choosing Air-Max Heating & Cooling, Inc.

This invoice is agreed and acknowledged. Payment is due upon receipt. A service fee will be charged for any returned checks, and a financing charge of 1.5% per month shall be applied for overdue amounts. Effective January 01, 2025 - a convenience fee of 3% will be applied to all credit card transactions. Customers may avoid this extra fee by paying with cash or check.
 Technician: Wiest, Hunter

1/24/2025

I find and agree that all work performed by Air-Max Heating & Cooling, Inc. has been completed in a satisfactory and workmanlike manner. I have been given the opportunity to address concerns and/or discrepancies in the work provided, and I either have no such concerns or have found no discrepancies or they have been addressed to my satisfaction. My signature here signifies my full and final acceptance of all work performed by the contractor.
 Technician: Wiest, Hunter



Remit To:
 JANI-KING OF JACKSONVILLE
 5700 ST. AUGUSTINE ROAD
 JACKSONVILLE FL 32207
 (904) 346-3000

Invoice	
Date 01/23/2025	Number JAK01250550
Due Date Upon Receipt	Cust # 480046
Invoice Amount \$ 525.00	Amount Remitted

Sold To:
 SIX MILE CREEK CDD

 6200 LEE VISTA BLVD
 STE 300
 ORLANDO FL 32801

For:
 THE REVERIE AT TRAILMARK

 35 RUSTIC MILL DR
 ST AUGUSTINE FL 32092

Make All Checks Payable To: JANI-KING OF JACKSONVILLE
 RETURN THIS PORTION WITH YOUR PAYMENT

JANI-KING OF JACKSONVILLE
 Commercial Cleaning Services
 (904) 346-3000



Sold To:
 SIX MILE CREEK CDD
 6200 LEE VISTA BLVD
 STE 300
 ORLANDO FL 32801

For:
 THE REVERIE AT TRAILMARK
 35 RUSTIC MILL DR
 ST AUGUSTINE FL 32092

Invoice No	Date	Cust No	Slsmn No	PO Number	Franchisee	Due Date
JAK01250550	01/23/2025	480046	MINI PEREZ		PRO-FRESH TEAM, INC	Upon Receipt

Quantity	Description	Unit Price	Extended Price
1	DEEP IMPACT CLEAN AS OUTLINED IN SCOPE OF WORK INCLUDING MACHINE SCRUB, INTERIOR/EXTERIOR WINDOW CLEANING #50 002-340-53800-46700 Received: 1/24/25 Approved: Matthew Reid CAM	525.00	525.00
Amount of Sale			\$ 525.00
Sales Tax			\$ 0.00
Total			\$ 525.00

Make All Checks Payable To:
 JANI-KING OF JACKSONVILLE

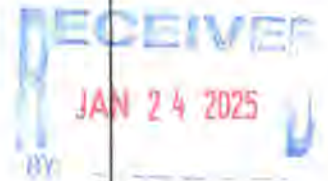

REVERIE

AT TRAILMARK

 RECEIVED
 JAN 24 2025
 BY:

Service Address:
 Reverie at Trailmark
 35 Rustic Mill Drive
 St. Augustine, FL 32092

Invoice Number: 11030847
Invoice Date: 1/24/2025
Terms: Net 30
Period Begin: 12/14/2024
Period End: 12/27/2024
Reverie: 100-OSPU

BILLING ADDRESS:
 FS Residential
 1601 SW 80th Terrace, Plantation, FL, 33324
 GL CODE 41011-00

Customer:
 Six Mile Creek CDD - Reverie
 475 West Town Place, Ste 114
 St. Augustine, FL 32092

Staff Reverie (East Parcel) Total Amount Due: \$4,993.37

Position title	Employee	Percentage	Type Hours	Hours Per Pay Period	Pay Rate	Amount
					Per hour	
#23 <u>Field Operations Mgmt</u> 2-320-338-122	Matthew Reid	10%	HOL	8.00	\$38.46	\$38.46
			REG	72.00	\$38.46	\$346.16
				80.00		\$384.62
<u>Administrator, On-Site Property</u> 2-340-828-121	Paula Linge	100%	HOL	8.00	\$20.60	\$206.00
			VAC	8.00	\$20.60	\$1,604.75
			REG	62.32	\$20.60	\$206.00
				78.32		\$2,016.75
<u>Field Mgmt/Admin</u> 2-320-538-122	Brian Hyman	100%	HOL	8.00	\$24.00	\$259.20
			REG	72.00	\$24.00	\$2,332.80
				80.00		\$2,592.00
	Subtotal					\$4,993.37
	Tax					\$0.00
	Total					\$4,993.37

Approved by CAM:

Matthew Reid

1/24/2025



Pay by Phone (844) 752-8845
 Phone (904) 209-2700
 Fax (904) 209-2718
 Toll Free (877) 837-2311

PO Drawer 3006
 St. Augustine, FL 32085

Statement Date 01/19/2025	Current Charges Due Date 02/18/2025
-------------------------------------	---

Current Month Activity				
Services Dates	Service Description	Units	Amount	Total
12/19/24	Amount of Your Last Statement			15.57
1/14/25	Payment - Thank You		-15.57	
	Past Due Balance			0.00
	Water Rates			
	Base Rate	15.45	1.00	15.45
Consumption Fees	0 - 5,000 Gallons	3.92	0.06	0.24
	Water Total		0.06	15.69
	Past Due Balance			0.00
	Current Charges			15.69
	Amount Now Due / Credits			15.69

SIX MILE CREEK CDD/TRAILMARK SUBDIVISION

Account Number:
556887-141819

Service Address:
255 RUSTIC MILL DR

Service Type:
Commercial

Days in Billing Cycle: 31

Deposit Amount: \$ 0.00

Deposit Date:

Geo Code: WGV

Meter Number: 89952575

Present Read Date: 01/19/2025

Previous Read Date: 12/19/2024

Current Reading: 641

Previous Reading: 635

Gallons Used: 60.00

#5

2 200-578 431



Past Due Balances are subject to a Late Fee of 1.5% or \$5.00, whichever is greater and disconnection of service if not paid.

MESSAGE CENTER

In 2023, SJCUD detected 13 contaminants in the drinking water. All contaminants were at allowable levels & no health based violations were reported. Please go to www.sjcf.us/WaterReport/NorthWest.pdf to view you report. This report contains important info about the source & quality of your water. To receive a hard copy of the report or if you have any questions please call 904-209-2700.

www.sjcutility.us

See reverse for monthly draft options or credit card payments.

Please detach and return with your payment.

FL29539F



ST JOHNS COUNTY UTILITY DEPARTMENT
 POST OFFICE DRAWER 3006
 ST AUGUSTINE FL 32085-3006

Account Number 556887-141819		Date Due 02/18/2025	
Past Due Amount	Current Charges/Credits	Amount Now Due	After Due Date Pay
0.00	15.69	15.69	20.69
Please Enter Amount Paid \$		15.69	



Please write your account number on your check and remit to:

ST JOHNS COUNTY UTILITY DEPARTMENT
 POST OFFICE DRAWER 3006
 ST AUGUSTINE FL 32085-3006



SIX MILE CREEK CDD/TRAILMARK SUBDIVISION
 6200 LEE VISTA BLVD STE 300
 ORLANDO FL 32822-5149

000000141819000000556887000000001569000000002069

Check for Address Change



Pay by Phone (844) 752-8845
 Phone (904) 209-2700
 Fax (904) 209-2718
 Toll Free (877) 837-2311

PO Drawer 3006
 St. Augustine, FL 32085

SIX MILE CREEK CDD/TRAILMARK SUBDIVISION

Account Number:
 556887-144358

Service Address:
 35 RUSTIC MILL DR

Service Type:

Commercial

Days in Billing Cycle: 31

Deposit Amount: \$ 250.00

Deposit Date: 04/22/2022

Geo Code: WGV

Meter Number: 89442386

Present Read Date: 01/19/2025

Previous Read Date: 12/19/2024

Current Reading: 313898

Previous Reading: 294359

Gallons Used: 195,390.00

#5
 2340536431

Statement Date

01/19/2025

Current Charges Due Date

02/18/2025

Current Month Activity

Services Dates	Service Description	Units	Amount	Total
12/19/24	Amount of Your Last Statement			3,316.08
1/14/25	Payment - Thank You		-3,316.08	
	Past Due Balance			0.00
	Water Rates			
	Meter Maintenance Charge	15.00	1.00	15.00
	Base Rate	231.61	1.00	231.61
Consumption Fees	0 - 75,000 Gallons	3.92	75.00	294.00
	75,001 - 150,000 Gallons	4.89	75.00	366.75
	150,001 - 300,000 Gallons	8.25	45.39	374.47
	Water Total		195.39	1,281.83
	Wastewater Rates			
	Base Rate	272.07	1.00	272.07
Consumption Fees	0 + Sewer Gallons	6.83	195.39	1,334.51
	Wastewater Total		195.39	1,606.58
	Past Due Balance			0.00
	Current Charges			2,888.41
	Amount Now Due / Credits			2,888.41

RECEIVED
 JAN 28 2025
 BY:

Past Due Balances are subject to a Late Fee of 1.5% or \$5.00, whichever is greater and disconnection of service if not paid.

MESSAGE CENTER

In 2023, SJCUD detected 13 contaminants in the drinking water. All contaminants were at allowable levels & no health based violations were reported. Please go to www.sjcll.us/WaterReport/NorthWest.pdf to view you report. This report contains important info about the source & quality of your water. To receive a hard copy of the report or if you have any questions please call 904-209-2700.

www.sjcutility.us

See reverse for monthly draft options or credit card payments.

Please detach and return with your payment.

FL29539F



ST JOHNS COUNTY UTILITY DEPARTMENT
 POST OFFICE DRAWER 3006
 ST AUGUSTINE FL 32085-3006

Account Number		Date Due	
556887-144358		02/18/2025	
Past Due Amount	Current Charges/Credits	Amount Now Due	After Due Date Pay
0.00	2,888.41	2,888.41	2,931.74
Please Enter Amount Paid \$		2888.41	



Please write your account number on your check and remit to:

ST JOHNS COUNTY UTILITY DEPARTMENT
 POST OFFICE DRAWER 3006
 ST AUGUSTINE FL 32085-3006



SIX MILE CREEK CDD/TRAILMARK SUBDIVISION
 6200 LEE VISTA BLVD STE 300
 ORLANDO FL 32822-5149

000000144358000000556887000000288841000000293174

Check for Address Change

**TURNER WGV LLC
6205 STATE ROAD 16
ST. AUGUSTINE FL 32094**

PHONE: (904) 907-2424

CUST NO: 4055	JOB NO: 000	PURCHASE ORDER:	REFERENCE:	TERMS: NET 20TH	CLERK: MAD	DATE / TIME: 1/27/25 12:22
-------------------------	-----------------------	------------------------	-------------------	---------------------------	----------------------	--------------------------------------

DUE DATE: 2/20/25 **TERMINAL:** 405

SOLD TO:
SIX MILE CREEK COMMUNITY
6200 Lee Vista Blvd, St 300

Orlando FL 32822

877-221-6919

SHIP TO:

TAX: ^{wgv} DEFAULT TAX CODE ST4

INVOICE: 9735 /4

SKU	MFG PART #	DESCRIPTION	SUGG	UNITS	PRICE /PER	EXTENSION
6013320	FH14000V	SPOT CLEANER CRPT&UPHOLS	139.99	1	139.99 EA	139.99 N
1549427	HG-R65341	WOOD&FURNTR REP MRKR 6PK	8.99	1	8.99 EA	8.99 N
1206622	K-1206622	CLEANING CLOTH TERRY 6PK	7.59	1	7.59 EA	7.59 N
87486	2710000613014	CLEANR SIMPLE GRN 67.6OZ	9.99	1	9.99 EA	9.99 N
		#30 002-340-53800-47500 Received: 1/27/25 Approved: Matthew Reid CAM				



(BRIAN HYMAN)
** AMOUNT CHARGED TO STORE ACCOUNT **

TAXABLE	0.00
NON-TAXABLE	166.56
SUBTOTAL	166.56

TAX AMOUNT	0.00
TOTAL	166.56

TOT WT: 19.50

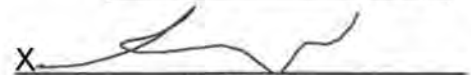
X 
Received By

SIXTH ORDER OF BUSINESS

Reverie Proposals Landscape & Irrigation Maintenance

Vendor	Year 1	Year 2	Year 3	Flowers	Mulch per Cubic Yard	Pin Straw per Bale	Three Year Total
Bland Landscaping Co	\$ 143,820.00	\$ 143,820.00	\$ 143,820.00	\$ 14,475.00	\$ 60.00	\$ 8.50	\$ 431,460.00
Brightview	\$ 136,200.00	\$ 139,605.00	\$ 143,095.00	\$ 9,760.50	\$ 65.00	\$ 8.78	\$ 418,900.00
Down to Earth	\$ 118,719.00	\$ 123,468.00	\$ 128,400.00	\$ 11,930.00	\$ 122.13	\$ 8.50	\$ 370,587.00
Duval Landscape	\$ 107,287.00	\$ 110,506.00	\$ 113,821.00	\$ 13,077.00	\$ 65.00	\$ 8.00	\$ 331,614.00
*Rupert Landscaping	\$ 87,515.70	\$ 87,515.70	\$ 87,515.70	Not Provided	Not Provided	Not Provided	\$ 262,547.10
The Greenery	\$ 116,376.00	\$ 116,376.00	\$ 119,876.00	\$ 8,762.76	\$ 74.25	\$ 7.08	\$ 352,628.00
United Land Services	\$ 113,760.00	\$ 113,760.00	\$ 119,448.00	\$ 9,327.00	\$ 82.49	\$ 9.00	\$ 346,968.00
Verdego Landscape	\$ 122,400.00	\$ 126,072.00	\$ 129,855.00	\$ 10,411.20	\$ 65.00	\$ 8.00	\$ 378,327.00
Yellowstone Landscape	\$ 106,896.00	\$ 110,102.00	\$ 113,405.00	\$ 2,964.30	\$ 62.00	\$ 9.00	\$ 330,403.00

*Rupert Landsacpe gave prices for Year 4 (\$92,845.41) and Year 5 (\$95,630.77)

SEVENTH ORDER OF BUSINESS



Amenity Policies

Revised/Approved 09.11.2024

Contents

- 1. Introduction4
- 2. Informed and Consent Agreement4
- 3. Code of Conduct5
- 4. Access Fobs6
 - 4.1 Member Access Fobs6
 - 4.2 Guest ID Badges7
 - 4.3 Care Giver ID Badge7
- 5. Service Animal Policy7
- 6. Alcohol8
- 7. Dress Code9
- 8. Amenity Facilities9
 - 8.1 Rules for Use of Amenity Facilities10
 - 8.1.1 Tavern 11
 - 8.1.2 Functional Rooms 11
 - 8.2 Swimming Pool and Spa 11
 - 8.2.1 General Pool and Spa Safety 11
 - 8.2.2 Health and Sanitation 12
 - 8.3 Fitness Facilities Etiquette 12
 - 8.3.1 Using equipment and others are waiting 13
 - 8.3.2 When you are finished with a piece of equipment 13
 - 8.3.3 Be aware of exercise area 13
 - 8.3.4 Avoid making too much noise 13
 - 8.3.5 Outside Trainers 13
 - 8.4 Fitness Class Etiquette 14
 - 8.5 Locker Rooms 14
 - 8.6 Outdoor Recreational Courts 15
 - 8.6.1 Pickleball Court Policies 16
- 9. Registered Resident Clubs 17
- 10. Community Postings 17
- 11. Fund Raising Events 17
- 12. Burning/Dumping/Littering 17

13. Golf Carts/Mopeds/Electric Bikes	17
14. Bicycles	17
15. Suspension and Termination of Privileges	18
15.1 Introduction	16
15.2 General Rule	18
15.3 Suspension and Termination of Rights	18
15.4 Administrative Reimbursement	19
15.5 Property Damage Reimbursement	19
15.6 Removal from Amenities	19
15.7 Initial Suspension from Amenities	19
15.8 Hearing by the Board; Administrative Reimbursement; Property Damage Reimbursement	20
15.9 Suspension by the Board	20
15.10 Automatic Extension of Suspension for Non-Payment	20
15.11 Appeal Board Suspension	21
15.12 Legal Action; Criminal Prosecution; Trespass	21
15.13 Severability	21
16. Non-Resident Annual User Fee	21

1. Introduction

The Amenity Center Policies of Reverie at Trailmark are established by the Board of Supervisors of the Six Mile Creek Community Development District (the “District”). These policies may be expanded, amended, or repealed by the Board of Supervisors, at a duly-noticed meeting of the District’s Board of Supervisors. However, in order to change or modify rates or fees beyond any increases that may be specifically allowed for by the District’s rules and regulations, the Board must hold a duly-noticed public hearing on said rates and fees.

All Reverie residents have the right to enjoy the use of the Amenity Facilities. Guests are welcome and accommodated as set forth in more detail herein. The Board, the Lifestyles Director, and its staff shall apply and enforce these policies. However, the Lifestyles Director shall have the authority to waive strict application of any of these Policies when prudent, necessary or in the best interest of the District and its residents. Such a temporary waiver of any policy by the Lifestyles Director shall not constitute a continuous, ongoing waiver of said policy, and the Lifestyles Director reserves the right to enforce all of these policies at any time he or she sees fit.

Hereafter the below titles will be identified as Residents or Paid Users:

- *Owners* are residents of Reverie who own their home, and family members living in the home.
- *Tenants* are individuals renting property from owners and use of the Amenity Facilities is only good during lease terms and upon written consent of the owners.
- *Paid User* is someone who pays the annual rate adopted by the District, which entitles such person to all the same rights to use the Amenity Facilities as an owner, as set forth in more detail herein.
- Owners, Tenants, and Paid Users shall collectively be referred to herein as *Patrons*.
- “Guest” – shall mean any individual who is invited to use the Amenity Facilities by a Resident, Non-Resident Member or Renter and possesses a valid guest pass issued by the Facility Staff.

2. Informed and Consent Agreement

All use of the Reverie Amenity Facilities and all participation in the Lifestyles program in Reverie are voluntary. Correspondingly, the recreational nature of the activities and programs potentially involves some personal and physical risk on the part of the participants. Program participation by Patrons is, therefore, interpreted as tacit acknowledgement and acceptance of the inherent risks. An Informed and Consent Agreement is attached and must be signed by every Patron before use of the Amenity Facilities.

3. Code of Conduct

The following outlines the Code of Conduct that shall be adhered to within the Amenity Facilities. Comments and complaints are to be civilly directed to the Lifestyles Director.

- Patrons and guests must conduct themselves so as not to jeopardize or interfere with the rights, privileges, and enjoyment of others.
- Patrons are responsible for the conduct of their guests. Guests will be held to the same standards of conduct as set herein for Patrons.
- Patrons and guests will refrain from loud, profane or indecent language.
- Patrons and guests will not harass or accost any other individual.
- Patrons and guests will not compromise the safety of others.
- Patrons and guests will not conduct loud entertainment as to disrupt the ability for staff to perform their work tasks or the peaceful enjoyment of other Patrons.
- Patrons will be held responsible for any damage to District property caused by the Patron and/or the Patron's guests.
- Patrons and guests shall not interfere with the management of the Amenity Facilities, nor reprimand or discipline any District, HOA, or Developer's employee. Comments and complaints are to be civilly directed to the Lifestyles Director.
- Patrons are not allowed to profit from the use of the Amenity Facilities. No solicitation of businesses and/or of services permitted in or around Amenity Facilities. Unless-vendor has been approved and has signed a vendor contract through the Lifestyles Director.
- Any Patron who violates the code of conduct or who violates any Amenity Policy is subject to disciplinary action, which may include suspension of the Patron's amenity privileges as set forth in more detail herein.
- Safety is paramount and any Patron or guest not adhering to the Amenity Policies stated herein and/or posted, will be asked to leave any Amenity Facilities or program. The district's staff's judgment will prevail in all instances.
- Loitering (the offense of standing idly or prowling in a place, at a time or in a manner not usual for law-abiding individuals, under circumstances that warrant a justifiable and reasonable alarm or immediate concern for the safety of persons or property in the vicinity) is not permitted at the Amenity Facilities.
- Firearms or any other weapons are prohibited in the Amenity Facilities during any governmental meetings or functions, including those of the district, and as otherwise prohibited in the Amenity Facilities in accordance with Florida law.
- All members and guests shall abide by and comply with any and all federal, state and local laws and ordinances while present at or utilizing the Amenity Facilities and shall ensure that any minor for whom they are responsible also complies with the same.

All District, HOA staff, Developer staff and contract labor are required to adhere to applicable CDD policies.

4. Access Fobs

- Access Fobs are solely for the use of the individual who is requisitioned the access fob.
- Patrons that have been placed in a state of suspension by the District are not eligible for replacement access fobs. They are also not eligible to purchase access fobs for renewal or allow guest(s) to use the facilities.
- The Lifestyles Department may complete access fob checks in order to determine validity of resident and guest identification. It is the responsibility of the Patron or guest to have access fob or guest badge on them at all times and available for compliance checks.
- Lost, stolen or damaged access fobs should be reported immediately and can be replaced for a fee.
- Any Patron or guest without a valid guest badge or access fob will be asked to leave the Amenity Facilities.

4.1 Member Access Fobs

- Patron access fobs are non-transferable and are not to be loaned or given to guests or other residents for entry. Patron access fobs are issued at no charge to each Patron with maximum of two per residence. Additional fobs may be purchased only for use by residents who live in the home.
- It is the responsibility of the Patron to keep all Patron information current and up to date with the Lifestyles Department.
- Any owner who transfers occupancy of their home is transferring their rights to use the Amenity Facilities with their access fobs. Upon transfer of occupancy, Patron access fobs will be deactivated.
- Any owner who leases or otherwise transfers occupancy of their home is not allowed to use the Amenity Facilities or member access fobs during the time a tenant occupying their home, unless they own and occupy another home in Reverie.
- Member access fobs for tenants shall terminate at the end of the Lease Term and must be returned to the Lifestyles Department. If a lease is renewed, the new lease must be submitted. Once this is completed, the member's ID will be updated with a new expiration date.
- Owners shall be responsible for all charges incurred by their tenants which remain unpaid after the customary billing and collection procedure established by the District. Owners are responsible for the department of their respective tenant.

4.2 Guest ID Badges

- Guest Badges are only necessary if guests use any of the Amenity Facilities. The only exception to this rule is if a guest is purchasing a ticket for an event.
- Each household may bring up to five guests to the Amenity Facilities. Patrons must accompany their guest(s) at all times. There is no limit on the number of times a Patron may bring a guest or guests to the Amenity Facilities. The Lifestyles Director shall have the authority to permit variations from the specific numbers in the guest policies as long as such variations are reasonable and consistent with the intent to not allow guests to become regular or excessive users of the District's facilities.
- Guest badges are required for all guests 3 years of age & older.
- A maximum of five guests are allowed at a time per household, per day unless approved in advance by the Lifestyles Director.
- Patrons must present their Patron access fob to obtain the guest badges.
- Guests who use the Amenity Facilities must report to and sign in at the front desk.
- Guest ID badges must be returned to the Lifestyles Department located in the Amenity Center.

4.3 Care Giver ID Badge

A caregiver or other person who provides care to a Patron while utilizing the Amenity Facilities is deemed to be a guest.

- A Patron must obtain a caregiver ID badge for the caregiver for use of the Amenity Facilities. Only one caregiver ID badge is permitted per household.
- Persons utilizing such caregiver ID badge are not permitted to utilize the Amenity Facilities other than to accompany the member under their care.
- The District shall set the fee of the caregiver ID badge and it will be non-transferable.
- Care Givers will have to establish eligibility with the Lifestyle Director.

5. Service Animal Policy

Dogs or other pets (with the exception of "Service Animal(s)" trained to do work or perform tasks for an individual with a disability, including a physical, sensory, psychiatric, intellectual, or other mental disability) are not permitted within any District-owned public accommodations including, but not limited to, the Amenity Facilities. A Service Animal must be kept under the control of its handler by leash or harness, unless doing so interferes with the Service Animal's work or tasks or the individual's disability prevents doing so. The District may remove the Service Animal under the following conditions:

- If the Service Animal is out of control and the handler does not take effective measures to control it;
- If the Service Animal is not housebroken; or,

- If the Service Animal's behavior poses a direct threat to the health & safety of others.

The District is prohibited from asking about the nature or extent of an individual's disability in order to determine whether an animal is a Service Animal or pet. However, the District may ask whether an animal is a Service Animal required because of a disability and what work or tasks the animal has been trained to perform.

6. Alcohol

- All Patrons must abide by the laws of the state of Florida governing alcohol and alcohol use and further agree to indemnify and hold harmless the District, its Board of Supervisors, officers, directors, consultants and staff from any and all liability, claims, actions, suits, or demands by any person, corporation or other entity, for injuries, death property damage of any nature, arising out of, or in connection with, the consumption of alcohol. Patrons and their guests agree that such indemnification shall not constitute or be construed as a waiver of the District's sovereign immunity granted pursuant to Section 768.28, Fla. Stat.
- Use of alcohol is not permitted when using the Amenity Facilities unless approved in writing in advance by the Lifestyles Department.
- Registered Resident Clubs may have BYOB events with alcoholic beverages for their personal consumption. Alcoholic beverages are not permitted at a Patron's private event or a Resident Clubs event unless a contract from an established catering company and license and liability insurance is provided to the Lifestyles Director in advance and approval is granted.
- Only catering companies, individuals or establishments licensed in the state of Florida and who carry at least \$1,000,000 liability insurance, are permitted to provide and sell alcoholic beverages during any event using the Amenity Facilities.
- If a Patron chooses to contract a vendor to provide or sell alcohol at an event using the Amenity Facilities, the Patron must provide a copy of the business license and their liability insurance to the Lifestyles Department before any event can take place.
- Individuals assume sole responsibility for any liability that may arise from alcohol consumption.

7. Dress Code

- Proper dress is required in all Amenity Facilities at all times.
- Shirts or coveralls and shoes must be worn when entering Amenity Facilities.
- Appropriate swimwear and/or bathing attire are required. No cutoffs or tethered swimwear allowed.
- Dry clothing is required at all times inside the Amenity Facilities. Wet swimsuits may only be worn in pool areas.
- Workout clothing such as shorts, t-shirts, warm-up suits, leotards and other exercise apparel that does not restrict movement or run the risk of getting caught in the equipment's moving parts are permitted.
- Closed toe and closed heel athletic shoes must be worn at all times in the fitness amenities. Aqua shoes may be worn in pool areas only.

8. Amenity Facilities

The District has the right, in its sole discretion and prior approval by an amendment to these policies, to rent or lease any portion of the Amenity Facilities on a short-term basis to any Patron or District sanctioned group for their exclusive use, including the right to include guests.

The Amenity Center Hours of Operation:

7 days per week

Lounge, game room, tavern, pools, bocci

8 am – 9 pm (fob access) closes at 10 pm

Fitness Center/Group Exercise: 5:00 am – 10 pm

Pickleball Courts: Dawn until 10 pm (lights go out).

All use of District Amenity Facilities is managed by the Lifestyles Director, requires completion and submission of a Resident Event Request Form and may be charged a fee as set forth in more detail herein. Patrons and guests are free to use any amenity without scheduling as long as the area is not reserved. Check for availability in advance with the Lifestyles Department before using any rooms. Amenity center is not available to rent for private resident parties/functions.

In scheduling space, the following hierarchy will be followed:

- District Lifestyles Department
- Registered Resident Clubs
- Patron special functions

8.1 Rules for Use of Amenity Facilities

- A Resident Event Request Form must be processed in advance and granted approval by the Lifestyles Department before use of any Amenity Facilities.
- After use of the facilities, it is the Patron and/or club's responsibility to leave area as was found.
- The number of people at the event cannot exceed posted room and bathing/occupancy capacity.
- Music for the event is allowed but the volume level must not interfere with the peaceful enjoyment of other Patrons using the Amenity Facilities or Patrons in the adjacent neighborhood.
- Smoking, including electronic cigarettes or cigars, is only permitted in the designated smoking areas away from entrances to Amenity Facilities. Smoking is also not allowed on any of the pool decks.
- Maximum hours Patrons are allowed to schedule an event is six hours, which includes time to set up and clean up.
- Additional provisions may be made by the Lifestyles Department or the District for special center events or club activities, provided the same is in compliance with applicable law.
- The District reserves the right to deny, adjust, cancel, reschedule, or move meeting space as deemed necessary. The District's Board of Supervisors may set reasonable limits on the number of times facilities may be booked by any club.
- Guests must be 18 years or older to use the indoor Amenity Facilities during hours of operation and must be able to present a valid guest pass while using the Amenity Facilities.
- Children under the age of 18 may tour the Amenity Facilities but are not allowed to visit or use the indoor Amenity Facilities. They may use the outdoor recreation areas and lounge pool only between the hours of 1pm-5pm, seven days a week and must be accompanied by a Patron.
- The spa and lap lanes are for adult use only.
- It is everyone's responsibility to report any maintenance or housekeeping concerns to the Lifestyles Department.
- Restrooms are available for use by Patrons and their guests and are located at the outdoor recreation area, inside the Lodge and at the pool deck.
- Patrons, vendors and guests are not permitted to solicit work or distribute flyers and other advertising material.

Patrons cannot profit from the use of the facilities. If someone wishes to be able to sell a product or service, they will need to be set up as a vendor through the Lifestyle Director. Vendors may only sell items during sanctioned events or as approved by the Lifestyle Director.

- Only animals that are considered Service Animals pursuant to Section 5 will be permitted in the Amenity Facilities.

8.1.1 Tavern

Use of the Tavern is for Patrons and their guests. No outside private functions other than those approved by the District will be allowed.

- To schedule use of the Tavern, a Resident Event Request Form must be completed at least four weeks prior to event date. Final approval by the Lifestyles Department must be granted.
- There is no charge for registered resident club functions.
- Review 8.1 of the Amenity Policies, Resident Event Request Form and Resident Club guidelines for Tavern use.
- Children are permitted in the Tavern for Patron functions or Patron club events but must be supervised by Patrons at all times.
- Events scheduled in the Tavern are not allowed to extend to the pool area or lobby.
- Catering kitchen and bar area can be scheduled for use during events but must be reserved in advance.

8.1.2 Functional Rooms

The Functional rooms are spaces that may be used by Patrons for a variety of activities, card and board games, as well as crafts. Room usage must be scheduled in advance through the Lifestyles Department. No special set up will be arranged in these rooms.

8.2 Swimming Pool and Spa

- Pool hours are based on Florida Department of Health and Environmental Control (DHEC) guidelines to include seasonal demand. Hours of operation are dawn to dusk.
- Children under the age of 18 are allowed to use the lounge pool from 1pm-5pm, seven days a week. Children in diapers (unless wearing swim diapers) and those not toilet trained are not permitted in the pool at any time.
- The spa and lap lane pool are for adult (18 years and older) use only.
- Appropriate swimming attire is required at all times.
- Chemicals used in the pool may affect certain hair or fabric colors. The District is not responsible for these effects.
- The District is not responsible for lost or stolen items.

8.2.1 General Pool and Spa Safety

- Only small flotation devices (like foam noodles) are allowed in the pool. Anyone bringing in oversized flotation devices will be asked to remove them.
- Lifeguards are not provided and facilities are designated as “Swim at Your Own Risk”. “Life buoys” and “shepherd’s crooks” are available at poolside for emergency use only.

- Individuals with hypertension, heart conditions or those on medication for any reason, should not use the spa without first consulting a physician.
- Individuals who have recently consumed alcoholic beverages should avoid using the spa and pool altogether.
- Children under the age of 18 are not permitted to use the spa.
- No outside fitness or physical therapy trainers are allowed in the pool/pool deck, unless previously set up as a vendor by the Lifestyle Director.
- Running, horseplay, profanity and disruptive conduct on pool deck area are not permitted. Diving into the pool is also not permitted.
- Any time lightning is observed, all swimmers must immediately vacate the pool and adjacent deck area until a safe environment is restored for a minimum of 30 minutes.
- The pool may be closed with no advance notice for certain activities, maintenance, repair, or inclement weather.
- Personal music devices may only be used on the deck and lounge areas and only with earphones. However, instructors may use portable radios for Lifestyle activities.
- Pool furniture is provided on a first-come, first-served basis and may not be reserved; personal items may not be left unattended. Furniture must be used on the deck and cannot be placed in the pool or removed from the pool area. If pool furniture is moved, it must be returned to its original position by the resident or guest. Association management must arrange for the removal and storage of pool furniture in the case of hurricanes and other severe storm warnings.

8.2.2 Health and Sanitation

- Showers must be taken before entering the pool.
- Food and beverages are allowed only at tables. Trash must be disposed of in appropriate containers. Glass containers and sharp objects are not permitted in the pool area.
- Only animals that are considered Service Animals pursuant to Section 5 will be permitted in the pool areas.
- Incontinent persons of any age are not allowed to use the pool or spa at any time. Children in diapers (unless in swim diapers) and those not toilet trained are not permitted in the pool at any time. Non-compliance could result in the pool and/or spa being closed for cleaning or draining because of a potential health hazard. The cost for cleaning/draining will be levied upon the Patron for non-compliance, including the non-compliance of the Patron's guest.
- Any person with a health problem that may be contagious to others is prohibited from using the pool and spa.
- No open wounds, even when covered with bandages, will be allowed in pool.

8.3 Fitness Facilities Etiquette

8.3.1 Using equipment and others are waiting

- Allow others to work in between your sets.
- Do not rest on exercise equipment - recovery is accelerated by light muscular activity such as walking about between sets rather than sitting.

- On cardio equipment, abide by the time limit (30 minutes) when others are waiting.
- Wipe equipment with a disinfecting “Gym Wipe” after each machine use to ensure a sanitary environment.

8.3.2 When you are finished with a piece of equipment

- Return equipment to its proper place when you have completed an exercise. Dumbbells should be placed in order on the rack and benches, mats and other equipment should be returned to their designated storage areas.
- Return weight on all machines to “0” to prevent the next user from injuring themselves.

8.3.3 Be aware of exercise area

- Stay clear of areas or stations that require space for your safety. Examples of such areas include weightlifting platform, cable crossover machine, and the weight trees. Do not crowd other exercisers.
- Do not exercise in a walking path, i.e.: in front of water cooler.
- Do not stand in front of the dumbbell rack as others will need clearance to get and put away their dumbbells.
- People vary widely in the ability to tolerate increases in body temperature associated with exercise. Exercise-induced heat stress can be extremely dangerous and/or life-threatening. Please be considerate of others’ needs for increased air circulation via ceiling fan use. Please show respect for other exercisers’ safety and comfort by asking before turning fans off or on, and approach differing individual physiological needs with a spirit of cooperation and compromise.

8.3.4 Avoid making too much noise

- Keep in mind an exercise facility is a public place where many participants are trying to concentrate on performing their exercises. Loud and constant noises can annoy other members.
- Do not initiate conversation with someone while they are engaging in weight training.
- Cell phones should be silent at all times in the fitness amenities. If you must take a call, please move out of the workout area to do so.
- Avoid dropping weights.

8.3.5 Outside Trainers

- No outside fitness or physical therapy trainers are allowed in the Gym. unless previously set up as a vendor by the Lifestyle Director.

8.4 Fitness Class Etiquette

- Classes are meant to be led by an instructor with as little distraction as possible to ensure safety for everyone attending the class.
- Do not enter a class once it has started. Arrive 10 min. early to set up your area.
 - To ensure your own safety, do not enter a class if you miss the warm up portion. Do not enter a class while arms or weights are swinging to avoid injury.
 - It is very distracting to your instructor and other Patrons when you arrive late or leave early.
- Do not disrupt a class by leaving early.
 - Proper cool down time and stretching is essential for your own safety and to prevent injury.
- Show your instructor respect by limiting chatter and focusing on their direction.
- Put your equipment (steps, dumbbells) away after class.
- Holding space for others is not allowed. Space is first-come, first-serve.

8.5 Locker Rooms

- Locker rooms and showers are provided for Patrons and guests.
- Lockers are available on a first-come, first-served basis. Clothing or personal effects may not be left unattended or unsecured in these areas, and safekeeping is the responsibility of the user. Lockers are to be used only when the Patron or guest is using the recreation areas of the Lodge.
- Lockers are for daily use only. Long term use is not allowed.
- Shower rules:
 - Turn off water when finished.
 - Minimize shower time so others are not waiting for long periods of time.
 - Be respectful of other people's personal space and belonging.
 - Cell phone usage is not permitted in locker rooms to protect the privacy of all Patrons and guests.

8.6 Outdoor Recreational Courts

Outdoor recreation, bocce and pickleball courts are available for Patrons and their guests.

- The District is responsible for maintaining the courts.
- Operational management rests with the District Management.
- The Lifestyles Department will maintain a reservation policy to ensure that registered Patron clubs for each sport has priority play.
- Open play will be available when registered Patron recreation clubs are not using the courts. Reservations to use the courts must be made through the Lifestyles Department in advance.
- All court users must wear the appropriate footwear to avoid damage to the playing surface.
- The Lifestyles Director will control whether bocce and pickleball is permitted in inclement weather, and the bocce and pickleball courts may be closed or opened at their discretion.

8.6.1 Pickleball Court Policies

As a courtesy to other Patrons, we ask that all players please recognize and abide by these rules and guidelines. Remember, not only is pickleball a lifetime sport, it is also a game of sportsmanship, proper etiquette and fair play.

- Proper pickleball etiquette shall be adhered to at all times. The use of profanity or disruptive behavior is prohibited.
- Proper shoes and attire, as determined by the Lifestyles Director, are required at all times while on the courts. Shirts must be worn at all times.
- Pickleball lights shut off at 10:00 PM.
- Pickleball courts are for Patrons only. The limit is three (3) Guests to a single court.
- No jumping over nets.
- Players must clean up after play. This includes “dead” balls, Styrofoam cups, plastic bottles, etc. The goal is to show common courtesy by leaving the court ready for play for Patrons who follow you.
- Court hazards or damages, such as popped line nails, need to be reported to the Lifestyles Director for repair.
- Persons using the pickleball facility must supply their own equipment (rackets, balls, etc.).
- The pickleball facility is for the play of pickleball only. Pets, roller blades, bikes, skates, skateboards and scooters are prohibited at the pickleball facility.
- Beverages are permitted at the pickleball facility if they are contained in non-breakable containers with screw top or sealed lids. No food or glass containers are permitted on the pickleball courts.
- No chairs, other than those provided by the District, are permitted on the pickleball courts.

- Lights, if any, at the pickleball facility must be turned off after use.
- Guests under the age of eighteen (18) are not allowed to use the pickleball facility unless accompanied by an adult Patron.
- The pickleball courts may be reserved by the District for District-sponsored events or functions.
- If you find it necessary to “bump” other players when it is your turn to play:
 - Never attempt to enter someone else’s court before your reservation time.
 - Never enter the court or distract players while others are in the middle of a point or game.
 - Wait outside the entrance gate and politely inform the players that you have a reservation time.
 - Allow players to finish out one more point, and then begin the player changeover for the court.
 - If you are bumped from a court and wish to continue play, please notify staff and they will do their best to get you on the next available court.

9. Registered Resident Clubs

Registered Resident Clubs are organizations approved by the District to foster and promote opportunities to pursue a hobby, recreational or cultural interests. They are the operational nucleus for the District’s recreation program and provide both structure and vitality in its mission.

- Any group of Patrons interested in pursuing a particular hobby, vocation or special field of interest may join together as a club and subsequently petition for District approval.
- Authority to grant approval rests with the Lifestyle Director and at times may require review by the District’s Board.
- Clubs are granted based on Patron’s need for a specific program, Patron interest, and the availability of the amenities and equipment.
- Governance for Resident Clubs is more specifically detailed in the Guidelines for Forming a Resident Club packet published by the Lifestyles Department.
- No Club events can be open to the public unless approved in advance by the Lifestyles Director.

10. Community Postings

- The Lifestyle Director will approve and post all Registered Resident Club fliers on the Reverie lifestyles newsletter. The decisions of District staff with respect to decorum will prevail at all times.
- Only Registered Resident Club announcements will be advertised on the newsletter and other community boards. Individual announcement must be approved by the Lifestyles Department.
- Commercial materials may be posted under certain circumstances as approved by the Lifestyles Director.

11. Fund Raising Events

- Resident Clubs are permitted to hold fundraising events as outlined in the Guidelines and Rules for Club packet. The Lifestyles Director must approve all fundraising events in advance.
- The Lifestyles Director may deny approval of any fundraising events that are inconsistent with the policies of the District.
- District guest policies apply to all functions.

12. Burning/Dumping/Littering

Patrons and guests are prohibited from burning and or dumping any items, including lawn/garden waste on common areas or in construction areas.

Littering is prohibited and Patrons can be fined. Using the District or construction dumpsters to dispose of personal/household material is strictly prohibited and residents may face fines or lose their Patron privileges.

13. Golf Carts/Mopeds/Electric Bikes

- All residents must abide by Florida laws governing the use of golf carts and mopeds.
- Please refer to applicable Florida law and the CC&R for full guidelines for golf cart use.

14. Bicycles

- The sidewalks/paths throughout Reverie are for both walkers and cyclists. A cyclist yields to a walker; however, a walker is not permitted to take up the entire walkway. The walker must allow the cyclist adequate room to pass safely. Residents walking in groups should walk single file when a cyclist is approaching.
- Patrons and guests operating bicycles on Reverie property must do so in a safe manner.
- Riders should limit their speeds to assure that they maintain control of their bicycles.
- Bicycles must be placed in or adjacent to the bike rack at The Retreat.

- The District does not accept any responsibility for lost or damaged bicycles.

15. Suspension and Termination of Privileges

15.1 Introduction

This rule addresses disciplinary and enforcement matters relating to the use of the District amenity facilities, and other District Property (together, the “Amenities”).

15.2 General Rule

All persons using or entering the Amenities are responsible for compliance with the rules and policies established for the safe operations of the District’s Amenities.

15.3 Suspension and Termination of Rights

The District shall have the right to restrict, suspend, or terminate access to the Amenities of any person and members of their household to use all or a portion of the Amenities for any of the following acts (each, a “Violation”):

- a. Submitting false information on any application for use of the Amenities, including but not limited to facility rental applications;
- b. Failing to abide by the terms of rental applications;
- c. Permitting the unauthorized use of a key fob or Access Card or otherwise facilitates or allows unauthorized use of the Amenities;
- d. Exhibiting inappropriate behavior or repeatedly wearing inappropriate attire;
- e. Failing to pay amounts owed to the District in a proper and timely manner (with the exception of special assessments);
- f. Failing to abide by any District rules or policies (e.g., Policies and Procedures);
- g. Treating the District’s staff, contractors, representatives, residents, landowners, Patrons, or guests, in a harassing or abusive manner;
- h. Damaging, destroying, rendering inoperable or interfering with the operation of District property, or other property located on District property;
- i. Failing to reimburse the District for property damaged by such person, or a minor for whom the person has charge, or a guest;
- j. Engaging in conduct that is likely to endanger the health, safety, or welfare of the District, its staff, contractors, representatives, residents, landowners, Patrons, or guests;
- k. Committing or is alleged, in good faith, to have committed a crime on or off District property that leads the District to reasonably believe the health, safety or welfare of the District, its staff, contractors, representatives, residents, landowners, [Patrons, or guests is likely endangered;
- l. Engaging in another Violation after a verbal warning has been given by staff (which verbal warning is not required); or
- m. Such person’s guest or a member of their household commits any of the above Violations.

Termination of Amenities access shall only be considered and implemented by the Board in situations that pose a long term or continuing threat to the health, safety and/or welfare of the District, its staff, contractors, representatives, residents, landowners, Patrons, or guests. The Board, in its sole discretion and upon motion of any Board member, may vote to rescind a termination of Amenities access.

15.4 Administrative Reimbursement

The Board may in its discretion require payment of an administrative reimbursement of up to Five Hundred Dollars (\$500) in order to offset the legal and/or administrative expenses incurred by the District as a result of a Violation (“Administrative Reimbursement”). Such Administrative Reimbursement shall be in addition to any suspension or termination of Amenities access, any applicable legal action warranted by the circumstances, and/or any Property Damage Reimbursement (defined below).

15.5 Property Damage Reimbursement

If damage to District property occurred in connection with a Violation, the person or persons who caused the damage, or the person whose guest caused the damage, or the person who has charge of a minor that caused the damage, shall reimburse the District for the costs of cleaning, repairing, and/or replacing the property (“Property Damage Reimbursement”). Such Property Damage Reimbursement shall be in addition to any suspension or termination of Amenities access, any applicable legal action warranted by the circumstances, and/or any Administrative Reimbursement.

15.6 Removal from Amenities

The District Manager, General Manager, Amenity Manager, Lifestyles Director, and onsite staff each have the independent ability to remove any person from the Amenities if a Violation occurs, or if in his or her discretion, it is in the District’s best interest to do so.

15.7 Initial Suspension from Amenities

The District Manager, General Manager, Amenity Manager, Lifestyles Director, or his or her designee may at any time restrict or suspend for cause or causes, including but not limited to a Violation, any person’s access to the Amenities until a date not later than the next regularly scheduled meeting date of the Board that is scheduled to occur at least twenty-one (21) days after the date of initial suspension. In the event of such a suspension, the District Manager or his or her designee shall mail a letter to the person suspended referencing the conduct at issue, the sections of the District’s rules and policies violated, the time, date, and location of the next regular Board meeting where the person’s suspension will be presented to the Board, and a statement that the person has a right to appear before the Board and offer testimony and evidence why the suspension should be lifted. If the person is a minor, the letter shall be sent to the adults at the address within the community where the minor resides.

15.8 Hearing by the Board; Administrative Reimbursement; Property Damage Reimbursement

- a. At the Board meeting referenced in the letter sent under Section 8 above, or as soon thereafter as a Board meeting is held if the meeting referenced in the letter is canceled, a hearing shall be held at which both District staff and the person subject to the suspension shall be given the opportunity to appear, present testimony and evidence, cross examine witnesses present, and make arguments. The Board may also ask questions of District staff, the person subject to the suspension, and witnesses present. All persons are entitled to be represented by a licensed Florida attorney at such hearing.
- b. After the presentations by District staff and the person subject to the suspension, the Board shall consider the facts and circumstances and determine whether to lift or extend the suspension or impose a termination. In determining the length of any suspension, or a termination, the Board shall consider the nature of the conduct, the circumstances of the conduct, the number of rules or policies violated, the person's escalation or de-escalation of the situation, and any prior Violations and/or suspensions
- c. The Board shall also determine whether an Administrative Reimbursement is warranted and, if so, set the amount of such Administrative Reimbursement.
- d. The Board shall also determine whether a Property Damage Reimbursement is warranted and, if so, set the amount of such Property Damage Reimbursement. If the cost to clean, repair and/or replace the property is not yet available, the Property Damage Reimbursement shall be fixed at the next regularly scheduled Board meeting after the cost to clean, repair, and/or replace the property is known.
- e. After the conclusion of the hearing, the District Manager shall mail a letter to the person suspended identifying the Board's determination at such hearing.

15.9 Suspension by the Board

The Board on its own initiative acting at a noticed public meeting may elect to consider a suspension of a person's access for committing any of the Violations outlined in Section 4. In such circumstance, a letter shall be sent to the person suspended which contains all the information required by Section 8, and the hearing shall be conducted in accordance with Section 9.

15.10 Automatic Extension of Suspension for Non-Payment

Unless there is an affirmative vote of the Board otherwise, no suspension or termination will be lifted or expire until all Administrative Reimbursements and Property Damage Reimbursements have been paid to the District. If an Administrative Reimbursement or Property Damage Reimbursement is not paid by its due date, the District reserves the right to request surrender of, or deactivate, all Access Cards or key fobs associated with an address within the District until such time as the outstanding amounts are paid.

15.11 Appeal Board Suspension

After the hearing held by the Board required by Section 9, a person subject to a suspension or termination may appeal the suspension or termination, or the assessment or amount of an Administrative Reimbursement or Property Damage Reimbursement, to the Board by filing a written request for an appeal (“Appeal Request”). The filing of an Appeal Request shall not result in the stay of the suspension or termination. The Appeal Request shall be filed within thirty (30) calendar days after mailing of the notice of the Board’s determination as required by Section 9(e), above. For purposes of this Rule, wherever applicable, filing will be perfected and deemed to have occurred upon receipt by the District. Failure to file an Appeal Request shall constitute a waiver of all rights to protest the District’s suspension or termination, and shall constitute a failure to exhaust administrative remedies. The District shall consider the appeal at a Board meeting and shall provide reasonable notice to the person of the Board meeting where the appeal will be considered. At the appeal stage, no new evidence shall be offered or considered. Instead, the appeal is an opportunity for the person subject to the suspension or termination to argue, based on the evidence elicited at the hearing, why the suspension or termination should be reduced or vacated. The Board may take any action deemed by it in its sole discretion to be appropriate under the circumstances, including affirming, overturning, or otherwise modifying the suspension or termination. The Board’s decision on appeal shall be final.

15.12 Legal Action; Criminal Prosecution; Trespass

If any person is found to have committed a Violation, such person may additionally be subject to arrest for trespassing or other applicable legal action, civil or criminal in nature. If a person subject to a suspension or termination is found at the Amenities, such Person will be subject to arrest for trespassing. If a trespass warrant is issued to a person by a law enforcement agency, the District has no obligation to seek a withdrawal or termination of the trespass warrant even though the issuance of the trespass warrant may effectively prevent a person from using the District’s Amenities after expiration of a suspension imposed by the District.

15.13 Severability

If any section, paragraph, clause or provision of this rule shall be held to be invalid or ineffective for any reason, the remainder of this rule shall continue in full force and effect, it being expressly hereby found and declared that the remainder of this rule would have been adopted despite the invalidity or ineffectiveness of such section.

16. Non-Resident Annual User Fee

- The Non-Resident Annual User Fee for any person not owning or renting real property within the District is \$4,000. This payment must be paid in full at the time of completion of the Non-Resident application and the corresponding agreement. This fee will cover membership to the Amenity Facilities for one (1) calendar year from the date it is purchased. Such fee may be increased by action of the Board of Supervisors. This membership is not available for commercial purposes.

Every member of a Reverie household will be required to sign the Amenity Center Guidelines before privilege to use the facilities will be granted.

SPECIAL EVENT RATES

Type	Rate
Event Ticket Prices	\$5.00 - \$35.00*/person
*For events that exceed \$35/person, such overage shall be paid directly to the vendor	

I hereby acknowledge I have read and understand these guidelines set by the Association and I agree to abide by these guidelines.

Reverie Address: _____

Primary Member Print Name: _____

Signature: _____ Date: _____

Secondary Member Print Name: _____

Signature: _____ Date: _____

Other Member of Household: _____

Signature: _____ Date: _____

Other Member of Household: _____

Signature: _____ Date: _____

EIGHTH ORDER OF BUSINESS

C.

From: Joe Durkin <Joe.Durkin@brightview.com>
Subject: Six Mile Creek CDD - Common Areas & Residential Pond Banks
Date: February 3, 2025 at 3:05:46 PM EST
To: Jim Oliver <joliver@gmsnf.com>
Cc: Steve McAvoy <Steve.McAvoy@brightview.com>

Jim,

Hope all is well

COMMON AREAS: We have added the following into our landscape maintenance estimate for Six Mile Creek CDD:

- Common Areas: Goldenrod, which we have serviced for the last two months
- Common Areas: Farmfield & Birdwatch Ct. Cut Through (Maintenance to be required starting this month)

*These are not large areas, but with the current price sensitivity of our audience, we felt it best to fold them in at no additional cost to the CDD, so they will be added to the service exhibit with no impact on the community price.

FPL (South End): We are not currently maintaining the area but were asked to price it for the prior RFP. Therefore, we have calculated and can provide a credit for the estimated number of occurrences per month considering the season. It's not a lot of money, but it will cover some minor tasks.

Residential Pond Banks: We've included pond banks abutting residential property per the attached map. This represents a significant increase in service to the district and we estimate the cost will be either:

- Option A: Mow and line trim from pond bank edge to approximately 6-12" from residential lot lines: \$37,000 annually.
- Option B: Leave 3-5 foot low maintenance buffer zone from pond bank edge and mow to appx 6-12" from residential lot lines, line trim to shape buffer 12 times per year: \$23,000 annually.
 - Better for environment
 - Better for safety
 - Better for finances
 - Better for erosion
 - Aesthetically Appealing (see attached images of low maintenance cuffs at one customer)

All My best,

Joe Durkin
Branch Manager
904.826.5798 call/text
joe.durkin@brightview.com



Exhibit B. Evergreen Management Map



D.

From: Megan Brown Maldonado <mbmaldonado@greenpointllc.com>
Subject: Re: Plans for the welcome center
Date: February 3, 2025 at 11:19:56 AM EST
To: Michelle Sutton <michelle.sixmilecreek@gmail.com>, Sarah Sweeting <:ssweeting@gmsnf.com>

Good Morning Michelle,
I hope you had a great weekend!

We met with an interior decorator and discussed a concept for redecorating the interior of the welcome center. We have no plans to redesign the space other than with furniture, paint and decor.

Attached is a rough sketch that the decorator brought to our initial in person meeting after visiting the community. Their idea was to repurpose the cabinets that are currently behind Stephanie's desk and place a large granite slab on top to create a large workstation with pop-up electrical outlets for residents to use. Barstools would be placed around the counter. In the cabinet's current place, a sitting area would be created out of built-ins with storage and upholstered chairs. According to this sketch, the existing tables and chairs would remain, while new artwork, wall decor and heavy drapery would be added to help with acoustics.

My concern with this proposed sketch, and what I've asked them to go back to the drawing board with, is that keeping the large cabinets and adding a granite countertop limits the use of the space. The same with the built-in seating. I feel as though the community would want to be able to rearrange the furniture easily to be able to suit the need for whatever event or party or meeting is happening, instead of having to set up around the bulky furniture.

The kitchen area won't change, so I think that being able to make the rest of the room as flexible as possible, with durable yet comfortable furniture, is key.

I've asked them to source new tables and chairs, possibly square tables instead of round, so that the tables could be put together to create longer, larger community tables if needed. I also think that keeping a sitting area is nice, however it should be focused near the television and still be able to be moved easily (so whether on sliders or on a rug), for community events.

Please let me know your feedback and the community's feedback after the meeting. Again, this sketch was an initial drawing by the interior decorator that we don't necessarily align with, but I wanted to share at least what has been provided to us.

We can certainly plan to have the decorator attend a meeting or workshop with the Board in the future once you all have received some input from the community.

Thanks,

Megan Maldonado | DRE Manager

GreenPointe Holdings, LLC
7807 Baymeadows Road East | Ste 205
Jacksonville, FL 32256

O: (904)299-6122 ext 5024
mbmaldonado@GreenPointeLLC.com

www.GreenPointeLLC.com

4 ottomans

2 New
Wooden
Live edge
Coffee tables
w/ metal bases

Plinth
for
Statue

New
Wishbone
Guest chairs

Table Desk.
Ex.

New Counter

New Indoor/outdoor
rug with bound
Edge.

Island
Ex.

Sink
Ex.

Restrooms

Ex

Ex

Ex

TV

Drapery Panels

New Art panels.

Trailmark Clubhouse

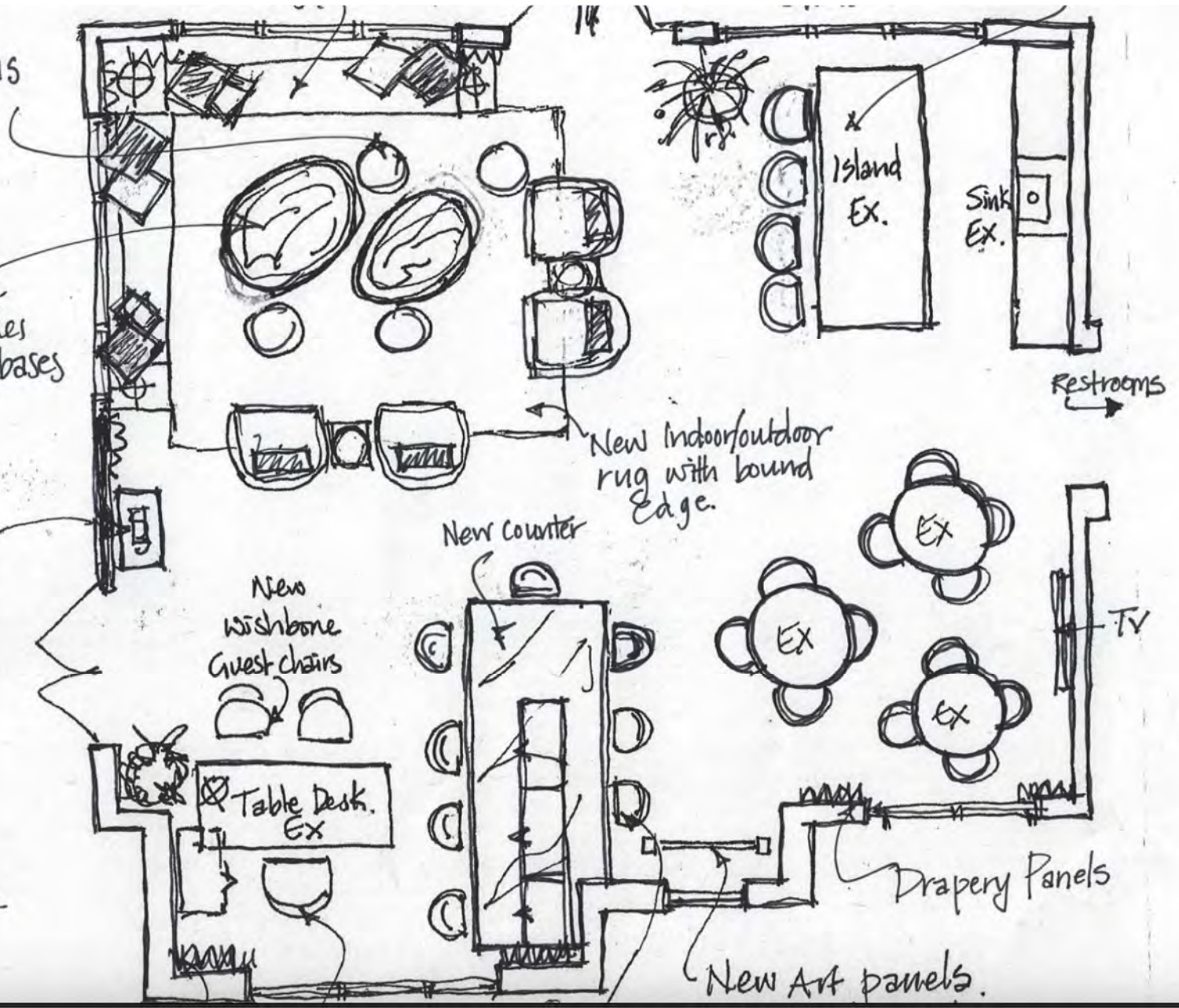

NINTH ORDER OF BUSINESS

***SIX MILE CREEK COMMUNITY
DEVELOPMENT DISTRICT***

REQUEST FOR PROPOSALS

FOR

AMENITY MANAGEMENT, FIELD OPERATIONS, AND MAINTENANCE SERVICES

February __, 2025

TABLE OF CONTENTS

1. *General Information for Proposers and Published Notice*
2. *General Description of District Facilities to be Managed*
3. *Scope of Services Needed/Job Descriptions*
 - Amenity Manager
 - Field Operations Manager
 - Maintenance Technician
 - Assistant Amenity Manager/Lifestyle Director
 - Guest Services Attendants (part time)
 - Pool/Deck Monitors
4. *Proposal Forms*
 - A. General Proposer Information
 - B. Experience
 - C. Pricing
5. *Alternative Proposal*
6. *Site Plan*

1. GENERAL INFORMATION FOR PROPOSERS

SIX MILE CREEK COMMUNITY DEVELOPMENT DISTRICT
REQUEST FOR PROPOSALS FOR AMENITY MANAGEMENT, FIELD OPERATIONS, AND
MAINTENANCE SERVICES

The Six Mile Creek Community Development District (the “District”) is seeking proposals from qualified firms interested in providing amenity management, field operations, and maintenance services for the District’s facilities. These services are considered contractual services under Florida law and are not required to be competitively bid. In order to submit a proposal, each Proposer must be authorized to do business in Florida, hold all required state and federal licenses in good standing, and otherwise meet any applicable requirements set forth by the District.

All proposals should include the following information, among other things described herein:

- A. Completed proposal forms as set forth herein.
- B. At least three references from projects of similar size and scope. The Proposer should include information relating to the work it conducted for each reference as well as a name, address, and phone number of a contact person(s).
- C. Complete pricing showing the total cost of providing the services, broken down as set forth on the following price proposal form. For any subcontractor being proposed, the total amount proposed to be paid by the District for these services shall be segregated between the actual funds being paid to the subcontractor and the mark up being charged by Proposer. Pricing for the months of October through September 2025, October 2025 through September 2026, and October 2026 through September 2027 SHALL be included by the Proposer.

All wishing to respond to the RFP are encouraged to attend an optional self guided onsite tour on XX/XX/XXXX @ XX:XX. Please check in with the front desk of the amenity center located at XXXX to receive an access fob and facility map.

Firms desiring to provide a proposal should submit a copy of the proposal via e-mail no later than [REDACTED], 2025 at 5:00 p.m. (EST) to Wesley Haber at Kutak Rock, e-mail wesley.haber@kutakrock.com.

Price will be one factor used in determining the proposal that is in the best interest of the District, but the District explicitly reserves the right to make such award to other than the lowest price proposal or to make no award at all. The District has the right to reject any and all proposals and waive any technical errors, informalities, or irregularities if it determines in its discretion it is in the best interest of the District to do so.

Nothing herein shall be construed as or constitute a waiver of District’s limitations on liability contained in Section 768.28, *Florida Statutes*, or other statute or law.

Any and all questions relative to this project shall be directed in writing by e-mail only to Wesley Haber at wesley.haber@kutakrock.com.

Published Notice

**REQUEST FOR PROPOSALS
AMENITY MANAGEMENT, FIELD OPERATIONS, AND MAINTENANCE SERVICES**

SIX MILE CREEK COMMUNITY DEVELOPMENT DISTRICT
St. Augustine, Florida

Notice is hereby given that the Six Mile Creek Community Development District (“District”) will accept proposals from qualified firms interested in providing amenity management, field operations, and maintenance services, all as more specifically set forth in the Request for Proposal Package (“RFP”). The RFP will be available beginning [REDACTED], 2025, at 12:00 p.m. (EST) and may be requested by e-mailing District Counsel, Wesley S. Haber, at Wesley.Haber@Kutakrock.com.

These services are considered contractual services under Florida law and are not required to be competitively bid. In order to submit a proposal, each Proposer must be authorized to do business in Florida, hold all required state and federal licenses in good standing, and otherwise meet any applicable requirements set forth by the District. Proposals, including the pricing information as set forth in the RFP, must be received by [REDACTED], 2025 at [REDACTED] .m. via electronic transmission to Wesley.Haber@Kutakrock.com

The District’s Board is expected to consider all proposals at their regularly scheduled meeting on [REDACTED], 2025, and/or at a later scheduled regular or special meeting. Price will be one factor used in determining the proposal that is in the best interest of the District, but the District explicitly reserves the right to make such award to other than the lowest price proposal or to make no award at all. The District has the right to reject any and all proposals and waive any technical errors, informalities, or irregularities if it determines in its discretion it is in the best interest of the District to do so.

Nothing herein shall be construed as or constitute a waiver of District’s limitations on liability contained in Section 768.28, Florida Statutes, or other statute or law.

Any and all questions relative to this project shall be directed in writing by e-mail no later than [REDACTED], 2025 by 5:00 p.m. to Wes Haber, e-mail Wesley.Haber@Kutakrock.com.

2. **GENERAL DESCRIPTION OF DISTRICT FACILITIES TO BE MANAGED**

The Six Mile Creek Community Development District is located within St. Johns County, Florida. The District owns, operates, and maintains various common areas, including ponds, landscape tracts, and conservation areas, and amenity facilities generally consisting of a club house, pools, fitness center, tennis courts, pickleball courts, kayak launch, trail system, basketball court and dog parks. Please participate in the self-guided tour for a detailed review of all of the District's amenity facilities. This RFP does not apply to Reverie at TrailMark.

3. SCOPE OF SERVICES NEEDED/JOB DESCRIPTIONS

Amenity Manager – This position directs and coordinates all activities of the Field Operations, Facility, and Lifestyle teams. Responsibilities and duties include:

- Create an atmosphere of First Class Service to residents through exemplary customer service experiences, engaging events, and maintenance of a “resort ready” Amenity Center.
 - Hire, train, support and coach Management and Clubhouse Personnel
 - Resolve escalated customer service challenges or issues
 - Ensure appropriate execution of District Amenity Policies
- Manage P&L including:
 - Proper monthly billing to the District for contracted and non-contracted services
 - Oversight for revenue collection and sharing with the District
 - Expense control for Programming and sponsored events
 - Review Invoices
- Manage District budget, including:
 - Operational expenses, special events, Holiday decorations
 - Capital Reserve projects
- Facilitate consistent communications with Field Operations Manager and Maintenance team to assist in priority setting and direction of key projects, maintenance and repairs.
 - Track times to completion, cost, and other pertinent information for projects completed in house
 - Ensure adherence to contracted services, time to completion, and any other pertinent information for projects requiring outside vendors
 - Assist in strategic planning of capital projects
 - Receive all proposals and monthly board report documents to compile and submit to the District
- Facilitate consistent communications with the Assistant Amenity Manager/Lifestyle Director to assist with priority setting and direction of key projects, events, and programming
 - Support seasonal hiring efforts via internet recruitment, job fair, and referrals for
 - Maintain strong relationships with programming department and third party vendors (fitness, swim lessons, swim team)
 - Provide any necessary follow-up with residents and/or the Board on incident reports, security breaches, or violation of rules or policy
 - Oversee yearly Resident Access Fob audit
 - Receive all monthly board report documents to compile and submit to the District
- Maintain positive relationships and communications with the District Manager and Board of Supervisors
 - Monthly reporting/presenting at Board meetings and workshops
 - Providing necessary information to Board in between meetings regarding project updates, major equipment failures or anything resulting in Amenity closure, security breaches or acts of vandalism, briefings on any resident brought before the Board for suspension of privileges, etc.
 - Individual project partnerships with appointed board members providing oversight

- Deliver effective presentations/public speaking in Board meetings, at community events, and in staff trainings and meetings
- Assist the Board in creating pertinent and effective Amenity Center policy
- Execute regular facility walk through/inspections with Field Operations and Amenity Managers and creating a priority list of repairs/maintenance based on those walk throughs
- Create and implement regular resident surveys to gain feedback on all aspects of the Amenity center, including policy, event/private rental satisfaction, fitness center and offerings, facility maintenance, etc.
- Create positive and effective resident communications via Eblast and social media regarding emergent issues like inclement weather closures, water main break procedures, or other situations that require a specific operating procedure
- Provide support to Clubhouse staff for large scale events
- Host seasonal New Resident Meetups to meet newly registered residents and answer all of their questions
- Bring funds collected on behalf of the CDD to the District Manager's office twice monthly in the summertime, monthly in the off season

Field Operations Manager – Provides day to day oversight of all District common areas and assets.

- Administer contract execution/compliance of all District contractors on both a project based or ongoing basis
 - Landscape
 - Pond Maintenance
 - Stormwater Management
 - Pool Service
- With Amenity Manager, manage District maintenance and repair budgets and Capital Improvement costs
- Submit monthly board reports and proposals to District Management 7 days prior to District submission deadline
- Write detailed scope of work for projects requiring outsourcing. Acquire appropriate work estimates and present to the Board as necessary
- Ensure all outside contractors meet all terms and conditions as written
- Provide timely responses to resident requests for service and complete as expeditiously as possible
- Working with Amenity Manager, remain fully aware of all safety and security issues or hazards within the community, communicating with appropriate District personnel and recommending or implementing appropriate corrective action or recommendations accordingly
- Maintain full knowledge of community landscaping, lake and wetland management
- Have advanced knowledge of electrical, plumbing, carpentry, painting, pools and other recreational management skills
- Assist in negotiating, purchasing and bidding of contracted services
- Monitor conservation areas
- Coordinate major repairs through District management
- Survey and maintain all community lighting
- Ensure debris does not collect and is removed from outfall structures to prevent flooding issues

- Along with Amenity Manager, implement District-approved capital projects and acquire a minimum of 3 bids on any recommended capital improvements
- Advise the District of necessary repairs, extraordinary cleaning, or replacement of items due to normal wear and tear, acts of God, or vandalism and secure cost estimates
- Maintain inventory of maintenance items and system of preventative maintenance
- Complete repairs and projects in house when able

Maintenance Technician – Full time support for Field Operations Manager in Maintenance and Repair Projects

- Is able to complete a variety of light plumbing, electrical, carpentry and paint work
- Assists with pools including vacuuming and filtration systems
- Maintains chemical balance of pools
- Routinely walks the grounds and reports any landscape, irrigation or security issues to management
- Assists Field Operations Manager with any key projects to be completed in house that would provide potential savings to the District versus outsourcing
- Blows off entire pool deck, removes debris from pool
- Maintains pet waste stations
- Pressure washes bathroom facility as needed
- Removes trash and debris from facility as needed
- Pressure washes when necessary
- Blows off tennis/pickleball court
- Brushes down cobwebs/spider nests, cleans bugs out of light fixtures
- Other duties as assigned by Field Operations Manager or Amenity Manager
- Maintaining Kayak Launch

Assistant Amenity Manager/Lifestyle Director – Maintains daily operations of the Amenity Center while creating and executing engaging events and programming for residents.

- Welcome residents and registered guests into the facility, giving tours, and otherwise providing positive Guest Services experiences
- Ensure proper registration of new residents in accordance with District policy
- Conduct regular walk throughs of facility to ensure opening, closing and cleaning checklist items are being completed and cleanliness maintained
- Communicate maintenance issues, irregular pool chemicals, needed fitness equipment repairs, janitorial issues, pests/rodents, etc, to Field Operations Manager
- Create/Plan/Execute fun and engaging events year-round for a variety of the demographics living at Six Mile Creek
- Manage Special Events budget
- Create staff schedules for Clubhouse, Seasonal, Private Rental, and Special Event staff
- Provide continued training opportunities for Clubhouse and Seasonal staff
- Supervise room setup for events and private rentals in the Camp House
- Ensure residents are following District Policy for utilizing the Amenities, provide guidance and information to residents who are not following policy, and provide thorough incident reports to Amenity Manager for situations that require escalation

- Provide additional Pool Deck supervision during peak hours of the summer season

Guest Services Attendants – The primary resident experience employee in the front office who welcomes patrons to the Amenity Center and assists with their needs

- Guest Service Attendant new employee training
- Private Rental Booking/Supervision
- Yearly Audit Management
- Weekly Update/Monthly Newsletter
- Create and send issue-specific eblasts when necessary
- Website Update/Maintenance
- Supply Inventory/Purchasing
- Greet residents and their guests as they enter the facility
- Monitor the key fob system as residents enter to ensure they are current, enforce age policy if young people come in without adults
- Answer new resident inquiries about how to register for access, collect all necessary paperwork and assign access fobs
- Perform light cleaning duties in the opening and closing checklists, including things like changing out garbage bags, refilling the soap/paper towel/toilet paper dispensers, Windex mirrors, dust in the gym, clean and arrange the Camp House for private rentals or special events. Unlocking bathrooms, the Camp House in the mornings. Picking up trash around the outside perimeter of the Amenity Center and parking lot.
- Doing regular walk-throughs of the facility to check supplies in the restroom and fitness center and to monitor activity
- Informing residents of CDD Amenity Center policy when necessary
- Assisting residents with private rental information and scheduling, accepting payments and signed agreements, and providing information about all rental policy
- Checking out private rentals at the end of the night by going through the cleaning checklist with them and noting any damages or incomplete checklist items for management
- Helping residents register for Tennis/Pickleball/Volleyball courts or make reservations for special events
- Assist pool deck staff with inclement weather closure confirmations, Code Brown documentation, incident/first aid reports
- Accept payments for access fobs, guest passes, any special event that requires a fee
- Answer phones, direct calls, take detailed messages when necessary
- Light computer work including resident registration into the database, answering email, checking weather radar

Pool/Deck Monitors – Provides an added layer of customer service and safety monitoring on the pool deck. Does not need to be a lifeguard.

- Greets all patrons
- Assists staff in informing and enforcing CDD Pool Deck policy
- Help office staff/management identify non-residents or non-authorized users of the pool deck area
- Monitor Camp House parties to ensure compliance with rental agreement and CDD policy

- Maintain a neat and presentable pool deck, arranging furniture, cleaning off surfaces, removing trash as necessary

4. **PROPOSAL FORMS**

4.A.
GENERAL PROPOSER INFORMATION

• *Proposer General Information:*

Proposer Name _____

Street Address _____

P. O. Box (if any) _____

City _____ State _____ Zip Code _____

Telephone _____ Fax no. _____

1st Contact Name _____

Title _____

2nd Contact Name _____

Title _____

Parent Company Name (if any) _____

Street Address _____

P. O. Box (if any) _____

City _____ State _____ Zip Code _____

Telephone _____ Fax no. _____

1st Contact Name _____

Title _____

2nd Contact Name _____

Title _____

- *Company Standing:*

Proposer's Corporate Form: _____
(e.g., individual, corporation, partnership, limited liability company, etc.)

In what State was the Proposer organized? _____ Date _____

Is the Proposer in good standing with that State? Yes ___ No ___

If no, please explain _____

Is the Proposer registered with the State of Florida, Division of Corporations and authorized to do business in Florida? Yes ___ No ___

If no, please explain _____

- *What are the Proposer's current insurance limits?*

General Liability \$ _____

Automobile Liability \$ _____

Workers Compensation \$ _____

Expiration Date _____

- *Licensure* – Please list all applicable state and federal licenses, and state whether such licenses are presently in good standing:

On a separate document to be included with your submittal, please provide responses to the following:

Provide details regarding the benefits you provide your employees (please differentiate between PT and FT)

Describe and provide examples of your approach to resident engagement: (eblasts, mobile apps, website, surveying, social media, newsletters, etc.)

Provide examples of recent Board Reporting for similar sized communities. (Amenity Manager Report, Lifestyle Report, Event Recap, Project Trackers, etc.)

Describe training provided to employees (HR, job specific, certifications, etc.).

Describe your approach to quality assurance with respect to the services you are proposing: What processes/tools do you use to ensure the quality of services you provide?

Describe what support onsite personnel get from corporate? (Operational Management, Payroll Support, HR, IT, Accounts Payable, etc.)

Do you offer a website platform for resident engagement that includes payment processing capabilities? If so, please provide the pricing details and if you're able to provide a demonstration?

Do you offer a maintenance website to help manage requests, repairs, and track repair status? If so, are residents able to report issues and receive status updates about the community?

- Please provide the following information for each project that is similar to this project, and that you are currently undertaking, or have undertaken, in the past five years. Attach additional sheets if necessary.

Project Name/Location: _____

Contact: _____ Contact Phone: _____

Project Type/Description: _____

Dollar Amount of Contract: _____

Your Company's Scope of Services for Project: _____

List of subcontractors used: _____

Is this a current contract? Yes ___ No ___

Duration of contract: _____

- Has the Proposer been cited by OSHA for any job site or company office/shop safety violations in the past five years? Yes ___ No ___

If yes, please describe each violation, fine, and resolution _____

Has the Proposer experienced any worker injuries resulting in a worker losing more than ten (10) working days as a result of the injury in the past five years? Yes ___ No ___

If yes, please describe each incident _____

- Please state whether or not the Proposer or any of its affiliates are presently barred or suspended from bidding or contracting on any state, local, or federal contracts? Yes ___ No ___ If yes, please provide:

The names of the entities _____

The state(s) where barred or suspended _____

The period(s) of debarment or suspension _____

Also, please explain the basis for any bar or suspension:

- *List any and all governmental enforcement actions (e.g., any action taken to impose fines or penalties, licensure issues, permit violations, consent orders, etc.) taken against the Proposer or its principals, or relating to the work of the Proposer or its principals, in the last five (5) years. Please describe the nature of the action, the Proposer's role in the action, and the status and/or resolution of the action.*

- *List any and all litigation to which the Proposer or its principals have been a party in the last five (5) years. Please describe the nature of the litigation, the Proposer's role in the litigation, and the status and/or resolution of the litigation.*

4.C.
PRICING

Proposed Fee for Services

a. FY2025 (October 1, 2024 – September 30, 2025)

Position	Annual Hours	Hourly or Salaried Wage (1)	Total Fee to CDD (2)
Amenity Manager	2080+		
Assistant Amenity Manager/Lifestyle Director	2080+		
Field Operations Manager	2080+		
Guest Services Attendants	1,040		
Maintenance Tech	2080		
Pool/Deck Monitors			
Totals	NA		

b. FY2026 (October 1, 2025 – September 30, 2026)

Position	Annual Hours	Hourly or Salaried Wage (1)	Total Fee to CDD (2)
Amenity Manager	2080+		
Assistant Amenity Manager/Lifestyle Director	2080+		
Field Operations Manager	2080+		
Guest Services Attendants	1,040		
Maintenance Tech	2080		
Pool/Deck Monitors			
Totals	NA		

c. FY2027 (October 1, 2026 – September 30, 2027)

Position	Annual Hours	Hourly or Salaried Wage (1)	Total Fee to CDD (2)
Amenity Manager	2080+		
Assistant Amenity Manager/Lifestyle Director	2080+		
Field Operations Manager	2080+		
Guest Services Attendants	1,040		
Maintenance Tech	2080		
Pool/Deck Monitors			
Totals	NA		

(1) Show as annual compensation for salaried and hourly rate for hourly employees at the beginning of the contracted year.

(2) The total charges to the District for providing the services. This cost may be broken out by line item or simply a total figure at the bottom of the table. This would be inclusive of any profit.

5. ALTERNATIVE PROPOSAL

IF THE PROPOSER DESIRES TO PROPOSE AN ALTERNATE APPROACH TO OPERATING AND MAINTAINING THE DISTRICT'S FACILITIES, THE PROPOSER IS STRONGLY ENCOURAGED TO SUBMIT BOTH A PROPOSAL RESPONSIVE TO THE STRUCTURE OUTLINED HEREIN AND A SEPARATE, ALTERNATIVE PROPOSAL. PROPOSER IS ENCOURAGED TO PROVIDE AS MUCH DETAIL AS POSSIBLE REGARDING THE ALTERNATIVE, INCLUDING, BUT NOT LIMITED TO, STAFFING, FEE STRUCTURES, DIFFERENT OR ADDITIONAL SCOPE OF SERVICES, DIFFERENT OR ADDITIONAL JOB DESCRIPTIONS, AND COSTS.

6. SITE PLAN

TENTH ORDER OF BUSINESS

January 13, 2025

Re: Pool Monitor Proposal for Six Mile Creek CDD (Trailmark)

POOLS OPERATIONS- Monitor Staff:

ELITE AMENITIES AGREES TO FURNISH A POOL MONITOR TO PERFORM AS OUTLINED IN THE “description of staff and duties” section.

DESCRIPTION OF STAFF & DUTIES:

>MONITORS ARE TRAINED AND OVERSEE THE POOL DECK AND ADMINISTERING OF THE STATED POOL RULES AND MONITORING REGULATIONS AS PROVIDED BY THE CUSTOMER. CUSTOMER WILL OUTLINE IN WRITING 30 DAYS TO THE PRIOR OF THE POOL OPENING DATE ANY SPECIFIC TRAININGS ON HOW THEY WANT MONITORS AND OR LIFEGUARDS TO ADMINISTER RULES AND ANY SPECIFICS TO THE PROPERTIES POOL THAT STAFF WILL NEED TO PERFORM OR ADMINISTER.

>MONITOR(S) WILL MAINTAIN A LOG OF ALL INCIDENTS AND COMPLETE DAILY CLEANING DUTIES TO INCLUDE STRAIGHTENING ALL DECK FURNITURE, UMBRELLA MANAGEMENT, PICKING UP POOL TOYS, LOST AND FOUND ITEMS AND LOCKING UP THE EXIT AT CONCLUSION IF REQUIRED.

> COMPANY REPRESENTS AND WARRANTS IT HAS SPECIFIC KNOWLEDGE OF ALL APPLICABLE LAWS, CODES AND REGULATIONS, WHETHER STATE, COUNTY, MUNICIPALITY OR OTHERWISE, REGARDING THE POOLS OPERATION, AND WILL ENSURE THAT ITS EMPLOYEES, AGENTS AND OTHER PARTIES FOLLOW ALL APPLICABLE LAWS, CODES AND REGULATIONS.

>POOL MONITORS WILL ABIDE BY THE COMPANY'S BEHAVIORAL CONDUCT PROVISIONS AND INFRACTIONS WILL BE DOCUMENTS AND HANDLED BY THE COMPANY BEHAVIORAL PERFORMANCE MANAGEMENT PROCESS AS OUTLINED IN THE EMPLOYEE BEHAVIOR CONTRACT THEY ARE REQUIRED TO SIGN ANNUALLY.

PERSONNEL:

All Company personnel shall be employed solely by the Company and be employees of the Company.

NO POOL MONITORS SHALL BE ENGAGED BY THE COMPANY AS AN “INDEPENDENT CONTRACTOR” TO FULFILL THE TERMS OF THIS AGREEMENT.

1. The Company agrees to pay the following for Company employees including all lifeguards:
 - a. Wages
 - b. income tax withholdings
 - c. Social security withholdings
 - d. State unemployment insurance
 - e. Federal unemployment insurance
 - f. Workmen's compensation insurance
2. The Company will train personnel. Personnel not performing up to the standards of the Company will be placed through the proper behavior and performance management process.
3. Pool Monitor Personnel will be trained and able to enforce the stated pool rules and regulations.
4. Personnel employed by the Company shall go through the Company's orientation training, onsite training, and ongoing training.
5. Pool Monitors shall have the authority to enforce Customer's and published and posted rules and minimum safety standards with swimmers and all other persons at pool facility, within their best judgment and sole discretion and remove patrons as determined by Company. The customer will provide 30 days prior to the start of the season: directions, including contact names, phone numbers and any other contact information on how infractions are to be handled by staff. The infraction directions will also include how the customer wants the company to handle non-compliant pool occupants during mandatory pool closures.
6. Company's supervisory staff will supervise personnel and will perform random inspections of the Customer's facilities and performance of personnel.
7. Company will invest substantial resources to train and convey information concerning operational techniques and management procedures to its employees at Customer's facility and Customer acknowledges that such information and investment is a valuable asset of Company's business.

POOLS CLOSURE EVENTS:

The Company or the Customer shall have the right to close the Facility early in the event of severe weather. Prolonged lightning, thunder and high winds shall constitute severe weather and are a danger to swimmers. Per the National Weather Service Guidelines and the American Red Cross, at the first occurrence of thunder or lightning, the pools(s) at the Facility shall be closed to swimmers for 30 minutes. Should thunder or lightning persist, pools shall remain closed until 30 minutes after the last occurrence of thunder or lightning. The deck area shall also be closed for 30 minutes after each occurrence of lightning. Lightning or Thunder regulations will be at the sole decision making of the trained and on staff monitor or lifeguard. Closures for non-severe weather events will not result in any billing or payment credits. Credits for severe weather events will occur if the pool is to remain closed for a minimum of 3 hours.

INSURANCE/LIABILITY:

The Company shall maintain and keep in full force the following coverage:

1. Worker's Compensation insurance covering all persons engaged on behalf of the Company in the performance of the terms of this agreement.
2. General and Professional Liability Insurance.

Company agrees to supply copies of certificates of insurance to the Customer verifying the above-mentioned insurance coverage upon request

OPTION 1:

DATES and TIMES:

May 24, 25, 26 2025 (Memorial Day weekend)	11am-7pm	
May 30-August 10, 2025 (Summer break)	11am-7pm	Daily
Aug 16,17,23,24,30,31, Sept 1 (Post Summer-Labor Day)	11am-7pm	

FEE:

Hourly Rate per staff member if total hours are 25 or more per week: \$26.66/hour (Rate will remain for the duration of the dates and times above). May 26, July 4, and September 1, 2025 are billed as 1.5X

Based on the above assumptions,

1 Pool Monitor - \$18,022.16

OPTION 2:

DATES and TIMES:

May 24th - September 1st (WEEKENDS ONLY)*	11am-7pm
---	----------

* Includes Memorial Day, July 4th, and Labor Day

FEE:

Hourly Rate per staff member if total hours are less than 25 per week: \$28.01/hour.

May 26, July 4, and September 1, 2025 are billed as 1.5X

Based on the above assumptions,

1 Pool Monitor - \$7,954.84

ELEVENTH ORDER OF BUSINESS

A.



Trailmark Drive next to Tabby Lake.



Amenity Center between the play field and parking lot. Caused during Touch-a-Truck.



Dolcetto Drive across from the play field.



Trailmark Drive between Weathered Edge and Goldenrod Drive.



Split Oak Rd near power lines.



These three are in the wide asphalt path along Trailmark Drive, between Seasons Court and Farmfield Drive.



B.

Miscellaneous items that need to be addressed.

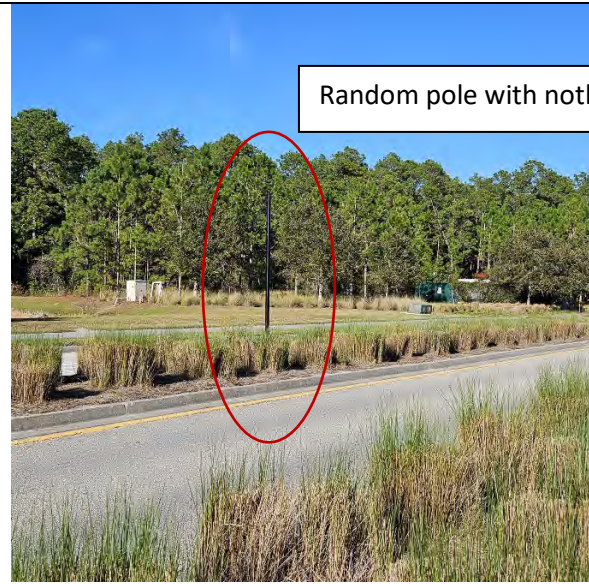

Random pole with nothing on it. Trailmark Dr. center island near pump station.



Random pole with nothing on it. Across from pickle ball courts.



Chain-link fence parts are other junk. To the right of the Trailmark Dr. mailbox kiosks.





Sign spray-painted over. Off Back Creek Dr.



Bench between canals has been missing for some time now?

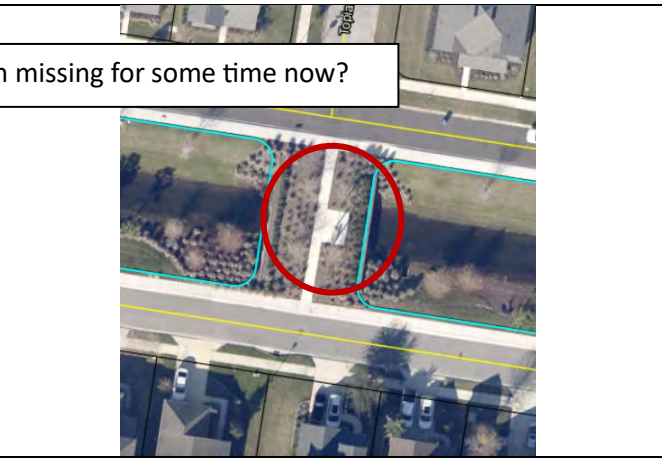

Wall capstones over Tabby Lake bridge need to be replaced.



THIRTEENTH ORDER OF BUSINESS

D.

1.

a.

Six Mile Creek CDD



Alex Boyer/Skip Reasonover
January 2025
Facility Manager Report

To: Six Mile Creek CDD
Jim Oliver
Wes Haber

Board of Directors
District Manager
District Attorney

Via E-mail
Via E-mail
Via E-mail

Facility Usage

Administrative Projects

- Staff continue to add new residents to community access control software.

Proposals

Maintenance Projects Completed

- New door handles on pool gates
- Final walkthrough for lap lane Warranty Drainage.
- Amenity Center Storm Drain fixed

Maintenance Projects in Process

- Pre Spring pressure washing
- Phase 9 Construction Irrigation & path warranty

Board Discussion Items

-

b.

FINAL PROGRESS REPORT FOR

Trailmark Amenity Expansion – Drainage Repairs

805 Trailmark Drive – St. Augustine FL 32092

RECIPIENTS:

Mike Taylor
Alex Boyer
Andy Ade
Antonio Franzese
Logan Gamache
Drew Veek

FOR THE WEEK ENDING: January 31st 2025

PREPARED BY: Antonio Franzese – Project Manager

WEATHER: Mild and Warm – no delays

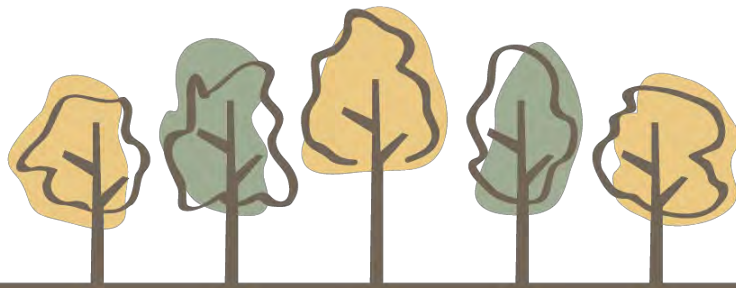

TRAILMARK

SAFETY & SITE NOTES

- Site & Safety Notes:
 - Demobilized Equipment, Removed Orange Temporary Fence and No Trespassing Signage
 - Removed all Barricades
 - Delivered and Staged All Sod Varieties
 - Removed Lock Box for Access Into Pool Area
 - Coordinated with Irrigation Vendor on Damage Repairs (caused by drainage install)
 - Monitored Daily Progress



THIS WEEK'S PROGRESS

- Sitework:
 - Complete All "Dome" Drain Basin Attachments at New Drains
 - Completed All Mulch Repairs
 - Completed All Sod Repairs at Drain Areas
 - Completed All Sod Repairs at Fence Line
 - Completed All Rock Work at Sports Courts
 - Install All Rocks at Drainage Inlets
 - Coordinated Follow Up Visit & Phone Call with ETM Engineers

PROGRESS SCHEDULED FOR NEXT WEEK

- Sitework
 - Remove Remaining Sod Pallets
 - Remove All Temp Fence Rolls @ Sports Courts
 - Monitor Irrigation and Drainage (pending rain)

OTHER GENERAL NOTES

- ETM to submit formal summary and follow up to Carlton by 2.7.2025.
- Punch Walk Completed @ 8AM 1.31.2025 (no formally documented issues) *Alex to monitor site during next 45-60 days prior to final 1 year punch walk in early March.

NEXT MEETINGS ARE SCHEDULED AS FOLLOWS:

- March 7th 9AM – 1 Year Final Warranty Walk Through

WEEKLY UPDATE PHOTOS:



Sitework: Sod Repairs @ Bathroom Area



Sitework: Sod Repairs @ Maintenance Gate



Sitework: Sod Repairs @ Fence Line



Landscape: Mulch and Plant Bed Repaired

CARLTON
CONSTRUCTION



Sitework: Sod Repalced @ Sports Courts



Sitework: Sod Replaced @ Gym Entry Door



Sitework: Rock Placement @ Sports Courts



Sitework: Excess Sod & Temp Fence (pending)